

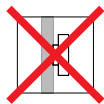

ZINER

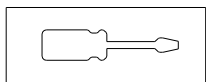
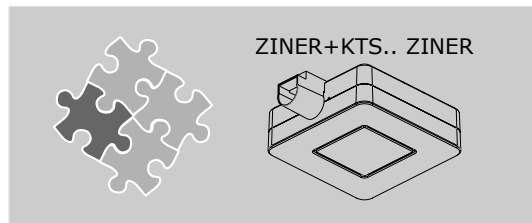
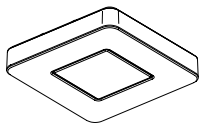

ES La luminaria debería colocarse de forma que no se espere una mirada prolongada a la luminaria a una distancia inferior a 2,3 m.

DE Die Leuchte sollte so platziert werden, dass ein langer Blick in die Leuchte in einem Abstand von weniger als 2,3 m nicht zu erwarten ist.

IT L'apparecchio (illuminante) dovrà essere collocato in modo tale da non prevedere una visione prolungata dell'apparecchio (illuminante) stesso a una distanza inferiore a 2,3 m.

NL De armatuur moet zodanig worden geplaatst dat er geen langdurige straling op de armatuur bij een afstand kleiner dan 2,3 m wordt verwacht.

PL Oprawa powinna być tak umieszczona, aby nie spodziewano się długiego wyglądu oprawy w odległości mniejszej niż 2,3 m.

EN The luminaire should be positioned so that prolonged staring into the luminaire at a distance closer than 2,3 m is not expected.

FR Il convient que le luminaire soit positionné de telle manière que le regard prolongé du luminaire à une distance inférieure à 2,3m en soit pas attendu.

PT A luminária deve ser colocada, de forma a assegurar que não haja um olhar prolongado para a luminária a uma distância inferior a 2,3 m.

RU Светильник должен располагаться так, чтобы длительное смотрение в светильник на расстоянии ближе 2,3 м не ожидалось.

يجب وضع وحدة الإنارة بحيث لا يتوقع نظرة مطولة على وحدة الإنارة على مسافة تقل عن 2,3 متر.

عربية

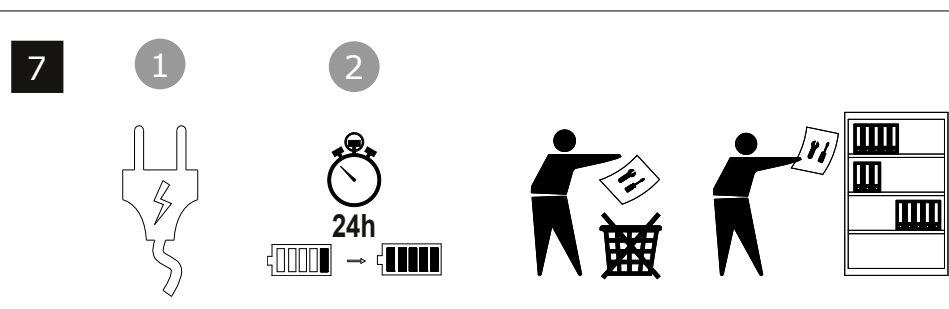
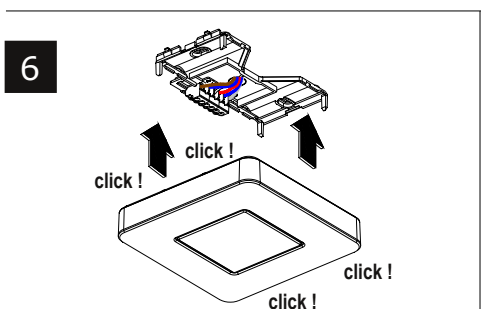
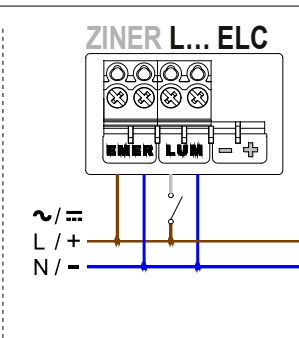
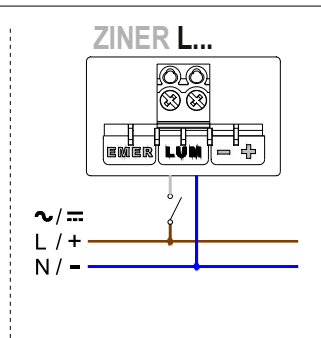
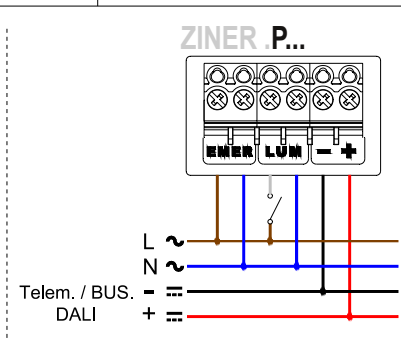
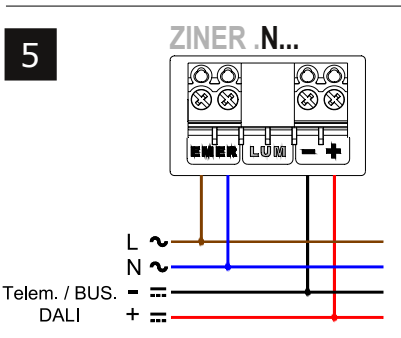
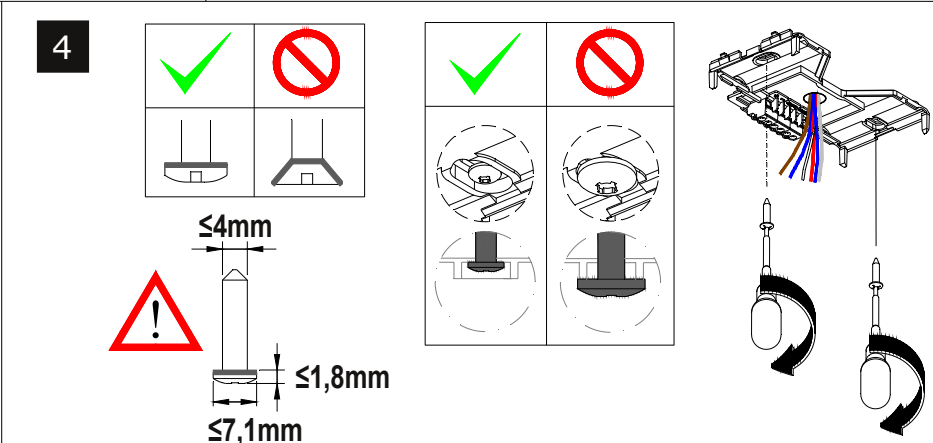
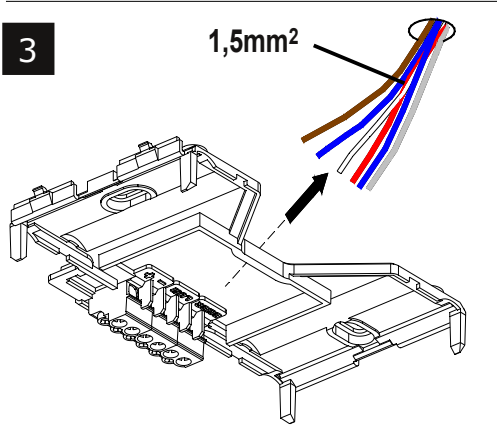
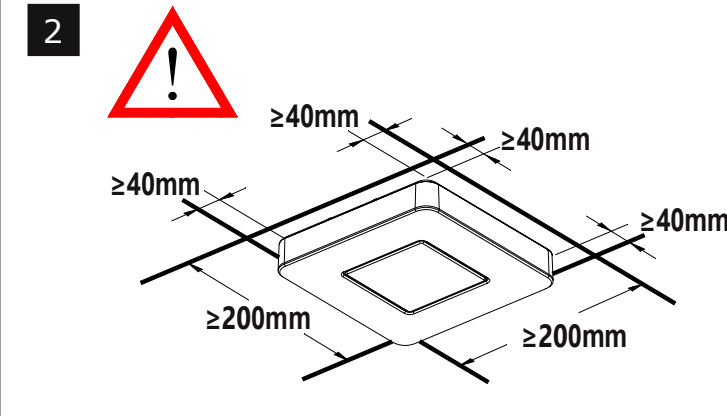
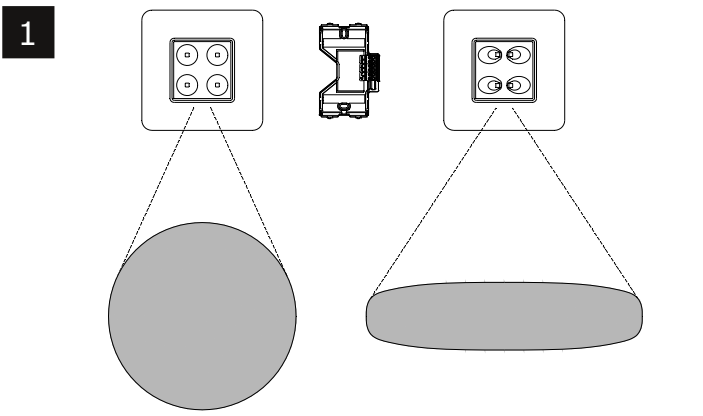

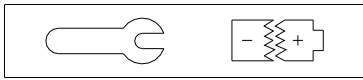

1

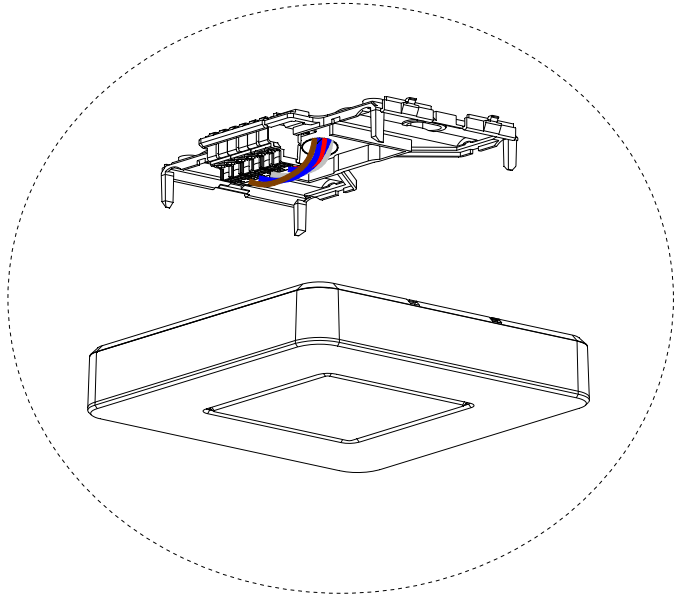
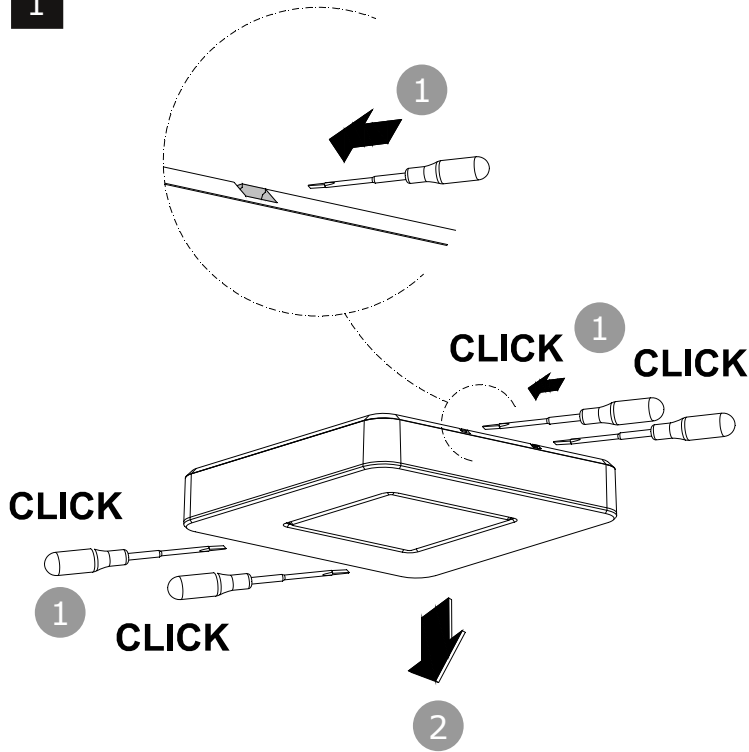

2

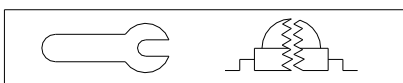
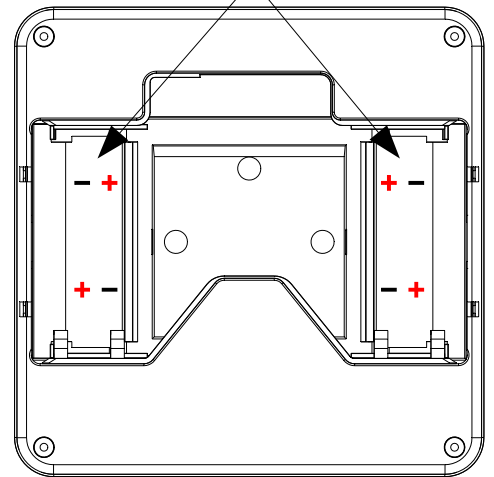
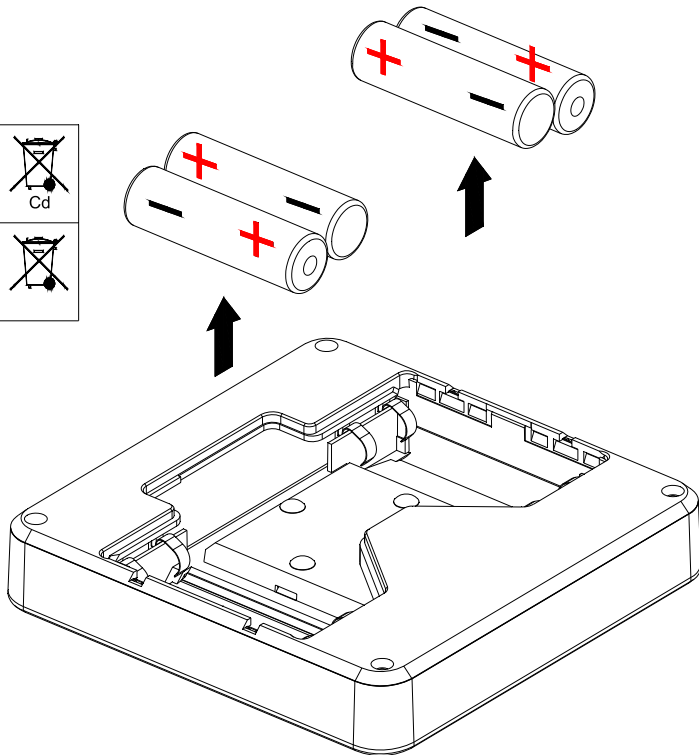
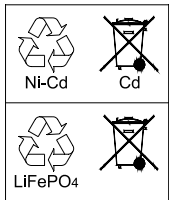

ES La fuente de luz sólo puede ser reemplazada por el fabricante o personal cualificado.
DE Die Lichtquelle darf nur vom Hersteller oder von qualifiziertem Personal Ausgetauscht Werden.
IT La sorgente luminosa può essere sostituita soltanto dal produttore o da personale qualificato.
NL De lichtbron mag enkel door de fabrikant of door erkende vaklui vervangen worden.
PL Źródło światła może być wymieniane tylko przez producenta lub wykwalifikowany personel

EN The light source may only be replaced by the manufacturer or qualified personnel.
FR La source de lumière peut uniquement être remplacée par le fabricant ou par du personnel qualifié.
PT A fonte de luz só pode ser substituída pelo fabricante ou pessoal qualificado.
RU Источник света может быть заменен только изготовителем или квалифицированными специалистами.

عربية لا يمكن استبدال مصدر الضوء إلا من قبل المنتج أو موظف مؤهل.