





LA LAMPE GRAS
XL OUTDOOR™
N°304 XL 75 SEA

Visit us at:
www.dcwe.fr

**INSTRUCTION
& USE SHEET**

CONTENU

IN THE BOX

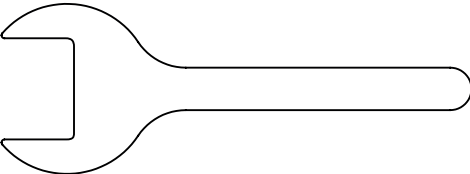
	x3
	x3
	x3
	x1
	x1
	x1

OUTILS NÉCESSAIRES

REQUIRED TOOLS

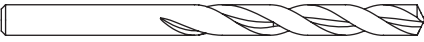
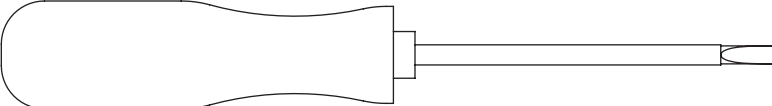
	Ø8
		

ATTENTION

- La sûreté de l'appareil n'est garantie qu'en suivant scrupuleusement les instructions précédentes. Il est donc nécessaire de les conserver.
- Isoler l'appareil du secteur avant toute manipulation.
- L'appareil ne peut pas être installé dans une autre position que celle indiquée dans les instructions de montage.
- Le montage et les manipulations de l'appareil devront être exécutés avec la plus grande attention pour ne pas abîmer ses composants.
- Tout changement d'ampoule respectera le type et la puissance indiqués dans le descriptif technique.
- Les composants métalliques, en verre ou autre seront entretenus à l'aide d'un chiffon doux et de détergent neutre.
- DCW ÉDITIONS n'échangera ses articles défectueux que par l'intermédiaire d'un revendeur.
- En cas de doute sur le branchement de cette lampe, veuillez consulter un électricien qualifié. Tout câble endommagé doit être remplacé par un professionnel qualifié.

WARNING

- The safety of this fixture is only guaranteed if the instructions have been observed.
- Always disconnect power before working on fixture.
- Fixture must not be installed in any position other than that shown in instructions.
- Assembly and maintenance of fixture must be performed carefully so as not to damage components.
- Replacement bulbs must be of same type and wattage as specified in instructions.
- Metal surfaces, glass or other parts of fixture may be cleaned with a soft damp cloth and mild detergent.
- DCW ÉDITIONS will replace merchandise with manufacturing defects only if it is returned to the retailer from which it was purchased.
- If you are unsure about your wiring, please consult a qualified electrician. The damaged cables should be changed by manufacturer or distributor or qualified electrician.



STEP 1.

Fr. Percez le joint à l'aide d'un tournevis

En. Pierce the seal with a screwdriver

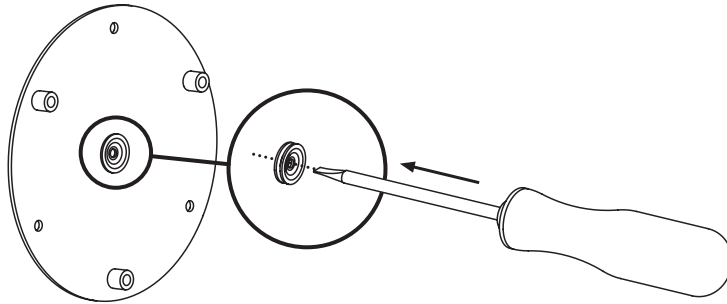

STEP 2.

Fr. Percez le mur à l'aide d'un foret diam. Ø8

En. Make holes in the wall with a Ø8 diam.

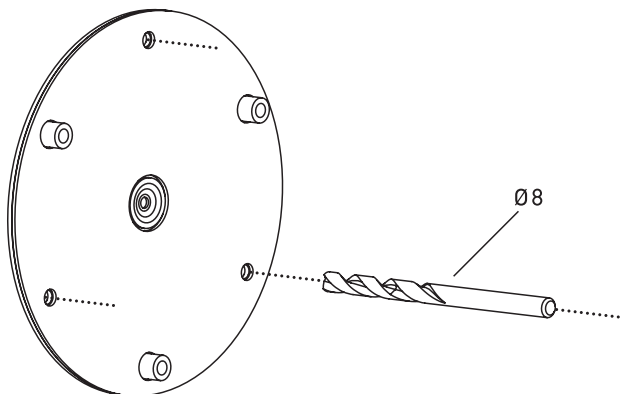

STEP 3.

Fr. Fixez la plaque au mur

En. Fix the plate

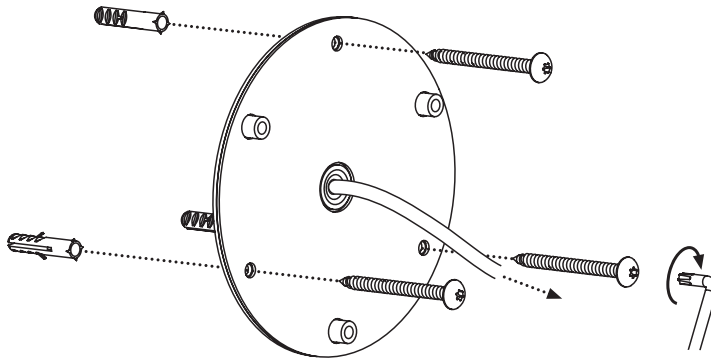

STEP 4.

a

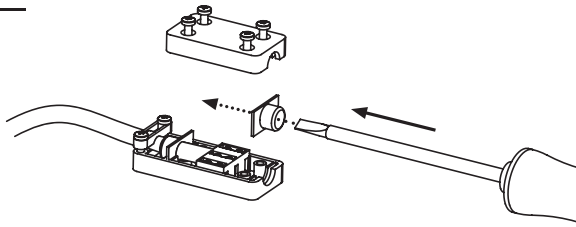

b

c

Fr. Connectez les deux câbles

En. Connect the wires

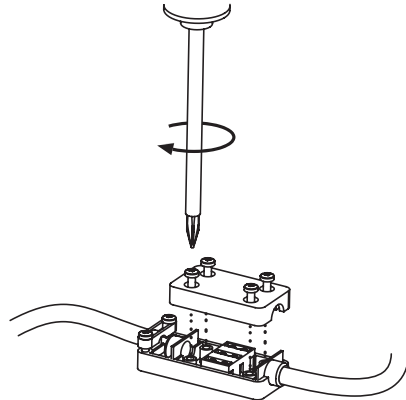
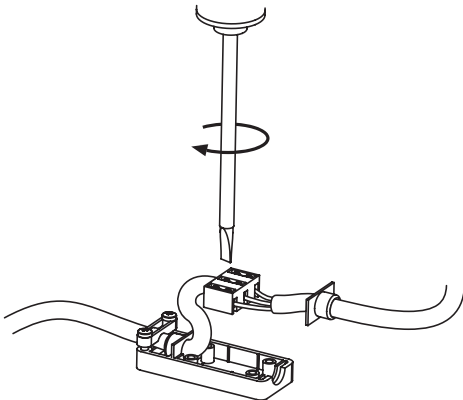

STEP 5.

Fr. Fixez la fonte à la plaque

En. Fix the cast on the plate

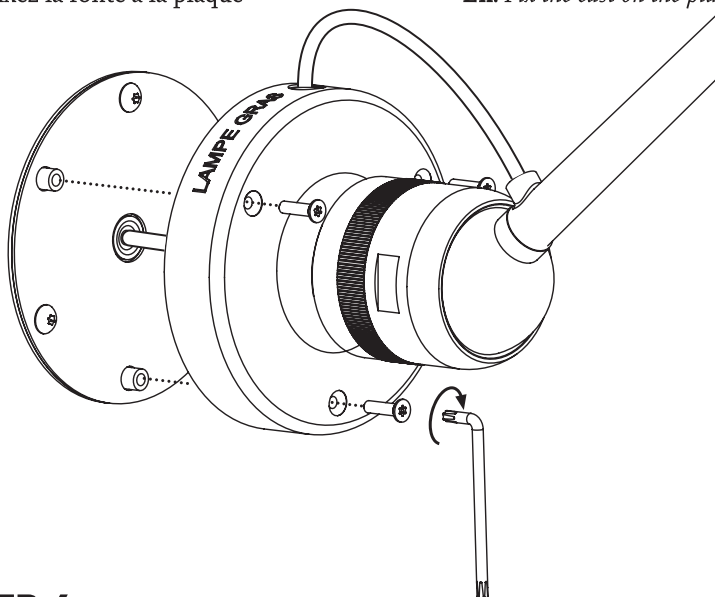

STEP 6.

Fr. Pour changer l'inclinaison de l'abat-jour et la position du bras, desserrez les vis de maintien à l'aide de la clé puis resserrez pour verrouiller la position.

En. To change the shade and arm position, unscrew the fixing screws with the wrench then screw to lock the position.

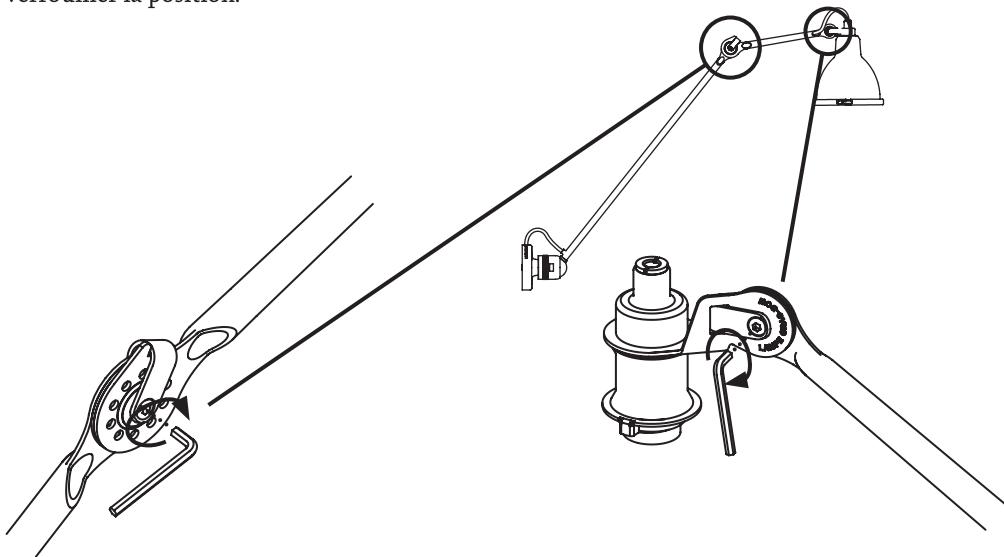

INSTRUCTIONS D'USAGES

USES INSTRUCTIONS

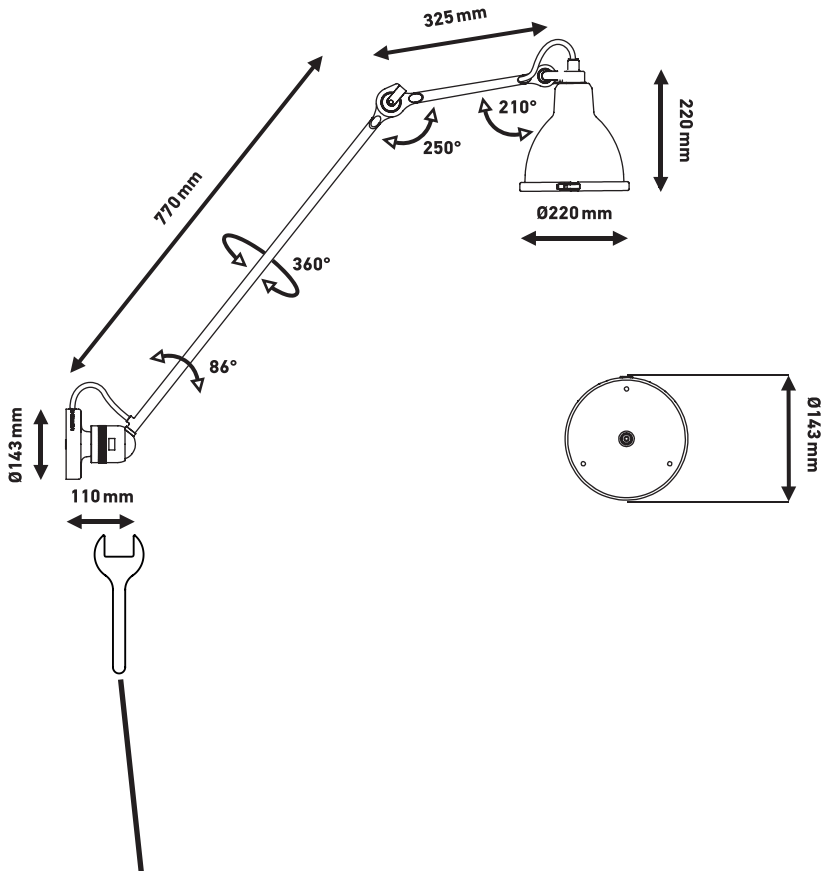

Pour durcir le mouvement serrez la bague de serrage/
To harden the arm motion rotate the locking ring clockwise



Visit us at:
www.dcwe.fr

DCWéditions
PARIS