

1 Traçage & perçage des trous de fixation
Trace & drill the mounting holes

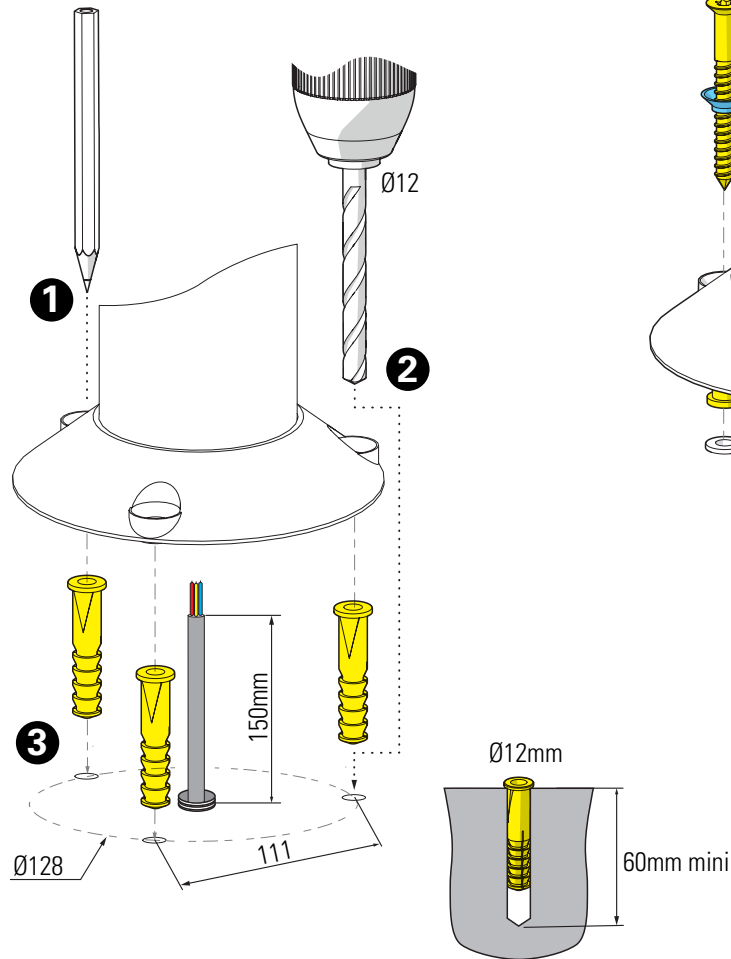

2 Fixation du luminaire
Fix the luminaire

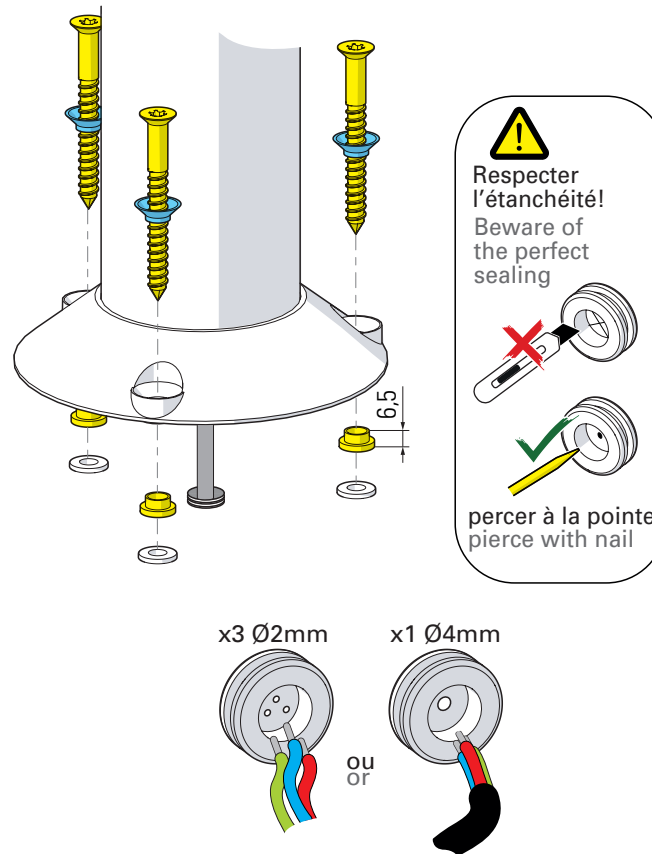

3 Retirer la tête
Remove the head

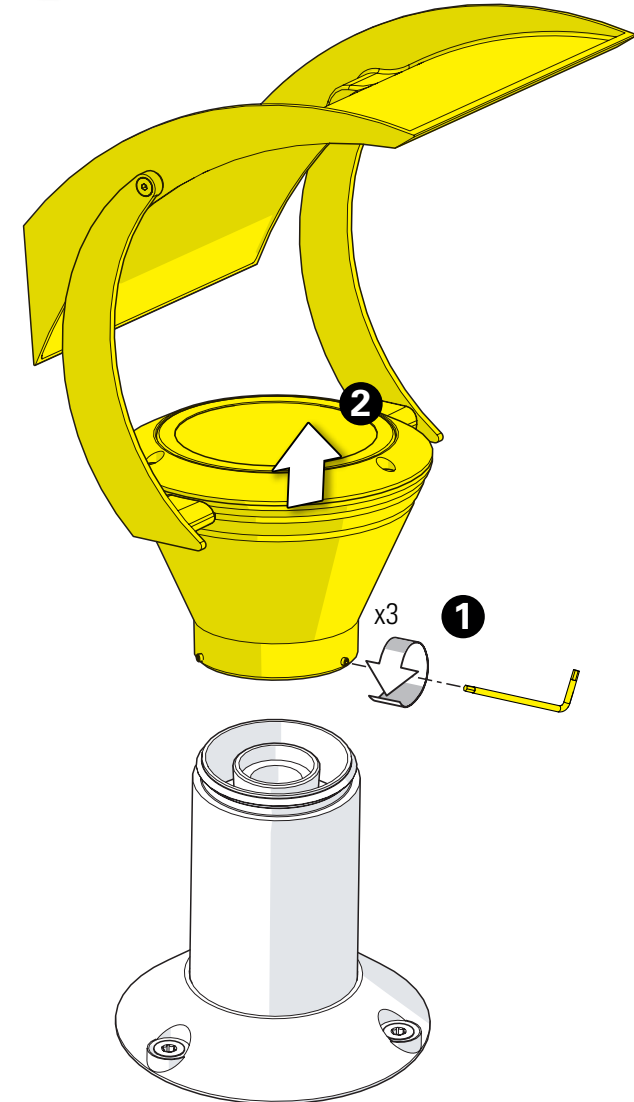

4 Raccordement électrique
Connect electrical wires

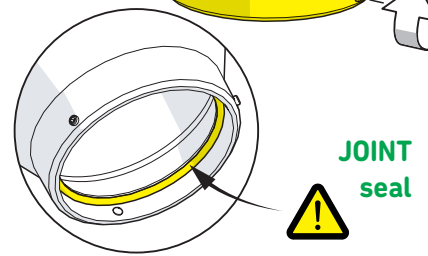
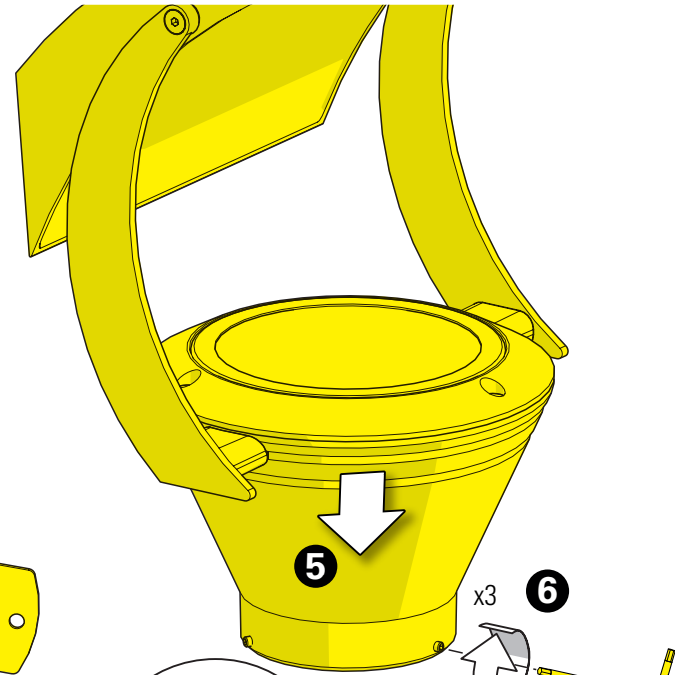
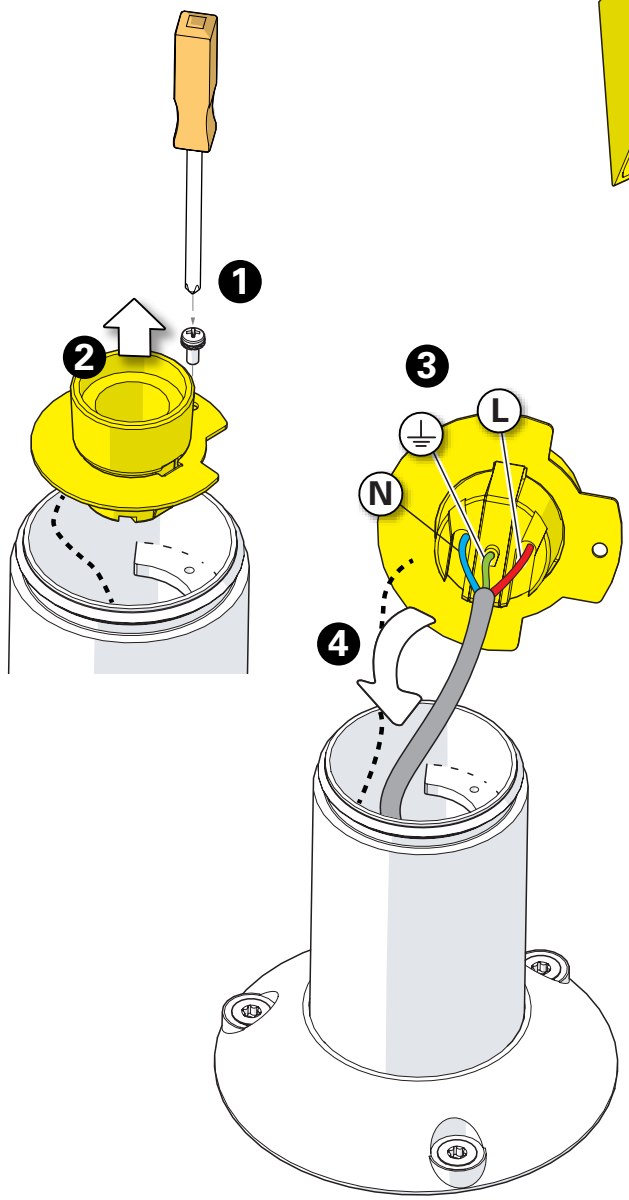

5 Montage de la lampe & du diffuseur
Install the light-bulb & the diffuser

