

SNEAK 2.0

INSTALLATION INSTRUCTIONS | AUGUST 2024

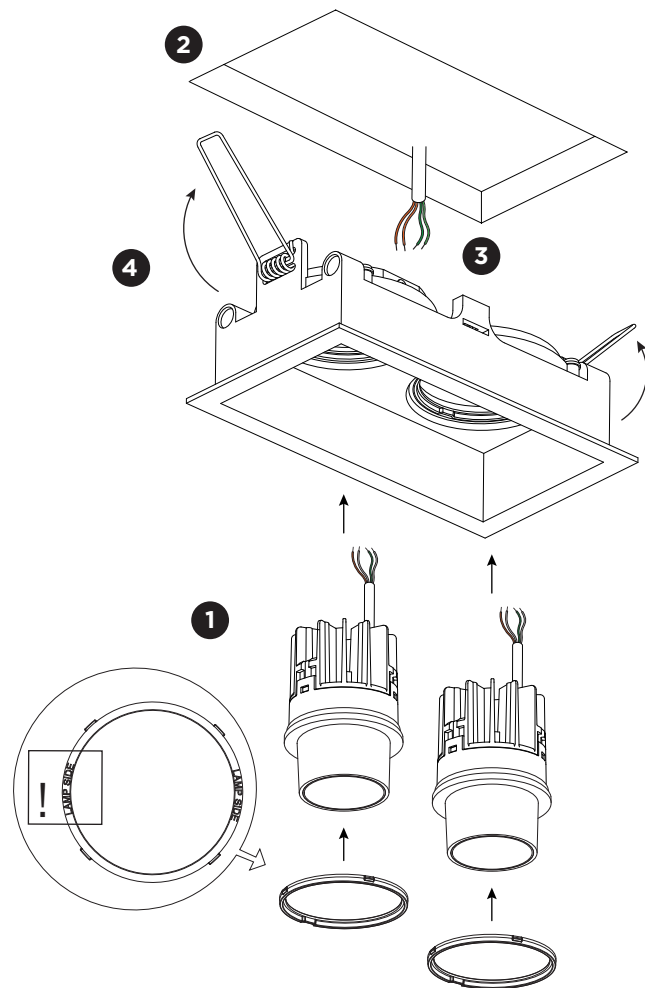

DIMENSIONS

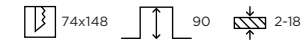
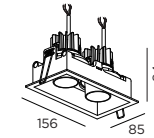

2.0 LOXONE

MOUNTING INSTRUCTION

- 1 Put the LED modules in the assembly set and fix them with the spring clips.
- 2 Make a hole in the ceiling according to the prescribed dimensions.
- 3 **POWER CONNECTION**
Connect the wires to the connectors.
Input voltage 20-28V.

- 4 Push the springs upwards and insert the fixture in the ceiling hole.



Power must be turned off before connecting the cables.

This fixture only works with Loxone TREE.



SNEAK 2.0

INSTALLATION INSTRUCTIONS | AUGUST 2024

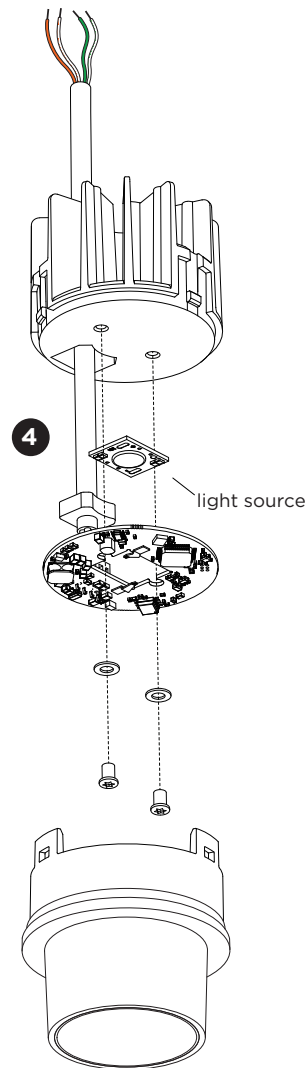
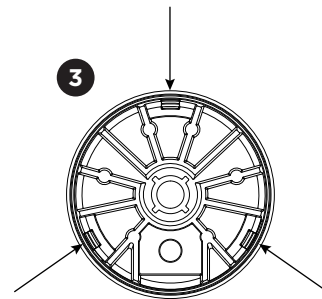
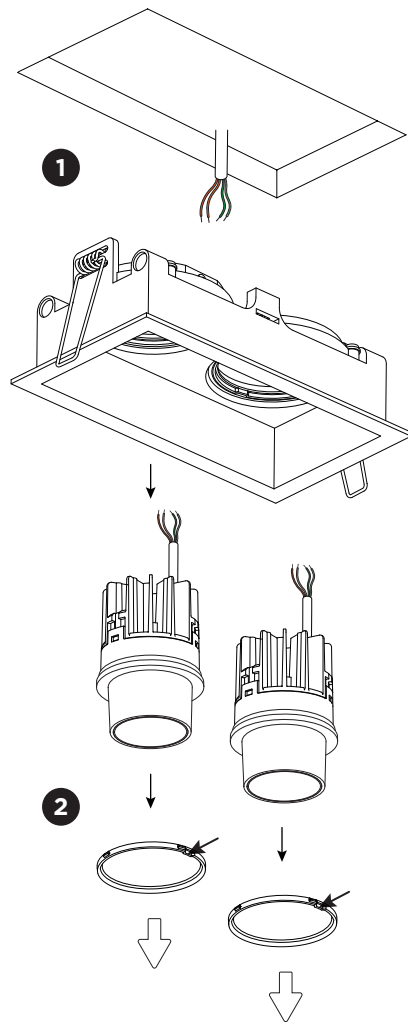

DISMOUNTING AND RECYCLING INSTRUCTIONS

Light source

- 1 Remove the fixture from the ceiling and disconnect the wires.
- 2 Push in the slot of the spring clip(s) and pull it/them down to remove the LED module(s).
- 3 Push at the three points to loosen the front ring(s).
- 4 Unscrew the light source(s) to remove it/them.

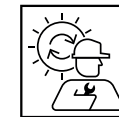

The light source is replaceable by Wever & Ducré or by a professional with explicit authorisation. For more information please contact your local Wever & Ducré customer service point.



This luminaire contains a light source with the energy class F.



WEVER & DUCRÉ
LIGHTING

WEVER & DUCRÉ BV
Spinnerijstraat 99/21, 8500 Kortrijk, Belgium
weverducre.com