

RINI SNEAK

INSTALLATION INSTRUCTIONS | AUGUST 2024

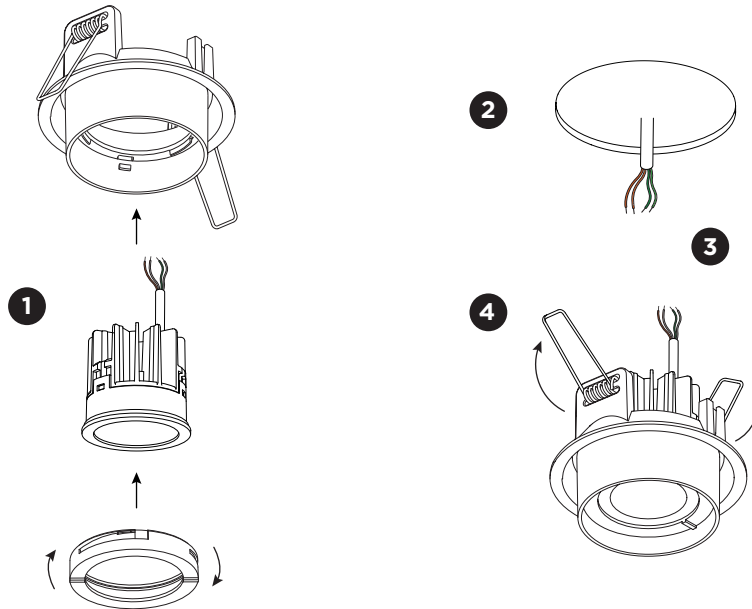

DIMENSIONS

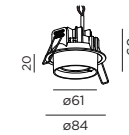

1.0 LOXONE

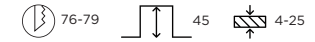

MOUNTING INSTRUCTION

- 1 Put the light source in the assembly set by locking the lamp ring in the housing by turning it a quarter clockwise.
- 2 Make a hole in the ceiling according to the prescribed dimensions.
- 3 **POWER CONNECTION**
Connect the wires to the connectors.
Input voltage 20-28V.



- 4 Push the springs upwards and insert the fixture in the ceiling hole.



Power must be turned off before connecting the cables.

This fixture only works with Loxone TREE.



RINI SNEAK

INSTALLATION INSTRUCTIONS | AUGUST 2024

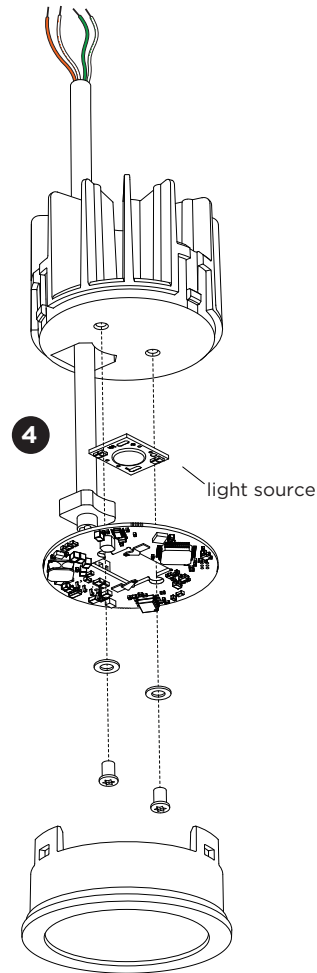
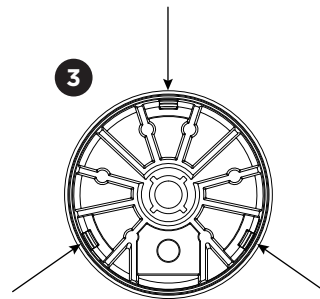
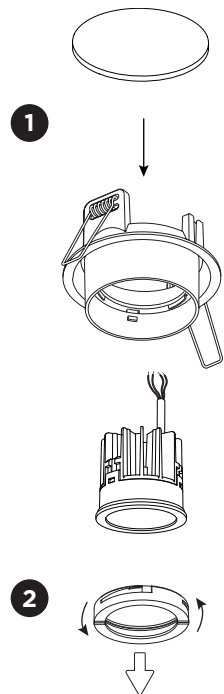

DISMOUNTING AND RECYCLING INSTRUCTIONS

Light source

- 1 Remove the fixture from the ceiling and disconnect the wires.
- 2 Hold and turn the front ring a quarter counterclockwise to remove the LED module.
- 3 Push at the three points to loosen the cover with lens.
- 4 Unscrew the light source to remove it.

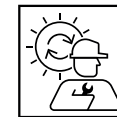

The light source is replaceable by Wever & Ducré or by a professional with explicit authorisation. For more information please contact your local Wever & Ducré customer service point.



This luminaire contains a light source with the energy class F.