

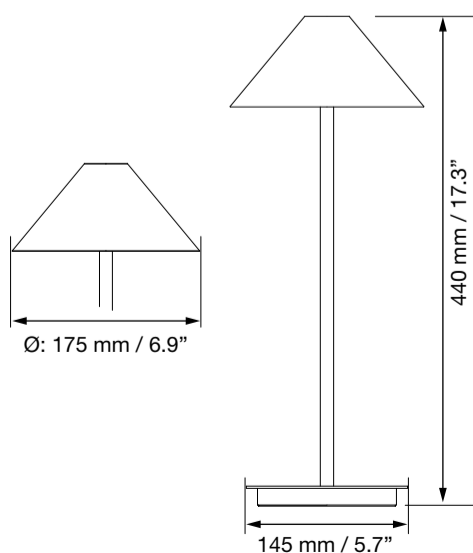



louis poulsen

KEGLEN 175 TABLE BASE MOUNTING INSTR. V2

DESIGNED BY
BIG

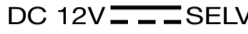

Lyskilde Light source Leuchtmittel Ljuskälla Sorgenti luminose Source lumineuse Fuente de luz Valonlähde ランプ 광원 光源	Spænding/frekvens Voltage/frequency Spannung/frequenz Spänning/frekvens Tensione/frequenza Voltage/frequence Tensión/frecuencia Jännite/taajuus 電源電圧 / 周波数 전압/주파수 電壓/頻率	Vægt Weight Gewicht Vikt Peso/ingombro Poids Peso Paino 質量 무게 重量	Isolationsklasse Protection Class Schutzklasse Isolationsklass Classe di isolamento Classe de protection Clase de aislamiento Eristysluokka 保護クラス 감전 방지 감전 보호	Tæthedsklasse Ingress protection Schutzart Kapslingsklass Grado di protezione Indice de protection Clase de protección Kotelointiluokka IP클래스 I방진방수 入口保護
LED  	AC100-240V, 50/60HZ	1,3kg / 2.53 Lbs	Cl. II	IP20
LED  	DC 12V  SELV	1,3kg / 2.53 Lbs	Cl. III	IP20

DA

Støv aftørres med en tør, blød klud. Fedtpletter og lignende kan fjernes med en blød klud opvredet i lunkent vand (<50° C) tilsat mildt rengøringsmiddel. Tør med det samme efter med en tør klud. Brug aldrig rengøringsmidler, der indeholder slibemiddel eller opløsningsmidler.

EN

Wipe off dust with a dry, soft cloth. Remove greasy spots etc. with a soft cloth dampened in lukewarm water (<50° C) with a mild detergent. Wipe immediately after with a dry cloth. Never use detergents containing abrasives and solvents.

DE

Staub bitte mit einem trockenen, weichen Lappen abwischen. Fettflecke und dgl. mit einem feuchten, in lauwarmem Wasser (<50° C) mit mildem Reinigungsmittel ausgewrungenen Lappen entfernen. Anschließend sofort mit einem trockenen Tuch abwischen. Niemals Reinigungsmittel mit Schleifmittel oder Lösungsmittel verwenden.

SV

Lampan dammtorkas med en torr, mjuk trasa. Fettfläckar tas bort med ljummet vatten (<50° C) utblandat med mildt rengöringsmedel. Torka omedelbart med en torr trasa. Använd aldrig rengöringsmedel som innehåller slipmedel eller lösningsmedel.

IT

Pulire la polvere esterna con un panno morbido e asciutto. Rimuovere macchie di grasso ecc. con un panno morbido inumidito in acqua tiepida (<50° C) e con un detergente leggero. Strofinare immediatamente con un panno asciutto. Non usare mai detergenti contenenti abrasivi o solventi.

FR

Essuyez la poussière avec un chiffon sec et doux. Enlevez les points de saleté etc. avec un chiffon doux imprégné d'eau claire tiède et de détergent doux. Essuyez immédiatement avec un chiffon sec. Ne jamais utiliser de détergents contenant des abrasifs et des solvants.

ES

Limpiar con paño seco y suave. Quitar manchas de grasa y otras con paño suave humedecido con agua templada (<50° C) con detergente poco agresivo. Limpiar inmediatamente después con un paño seco. Nunca use detergentes que contengan abrasivos y disolventes.

FI

Pyyhi pölyt kuivalla pehmeällä liinalla. Poista rasvatahrat miedolla pesuaineella ja haalealla vedellä (<50° C) kostutetulla pehmeällä liinalla. Pyyhi välittömästi kuivalla liinalla. Älä koskaan käytä liuottimia tai hankausaineita sisältäviä pesuaineita.

KR

부드럽고 마른 천으로 먼지를 닦아내십시오. 기름때 등의 경우 중성세제를 섞은 미지근한 물(50°C 이하)에 적신 부드러운 천으로 닦아주세요. 마른 천으로 즉시 닦아내십시오. 연마재나 용제가 포함된 세제는 절대 사용하지 마세요.

CN

用乾燥的軟布擦去灰塵。用沾有溫和清潔劑的溫水 (<50° C) 的軟布去除油漬等。之後立即用乾布擦拭。切勿使用含有研磨劑和溶劑的清潔劑。

JP

乾いた柔らかい布でホコリを拭き取ってください。油汚れは、中性洗剤を溶かしたぬるま湯(50°C以下)を浸した柔らかい布で拭き取ってください。直後に乾いた布で拭いてください。研磨剤や溶剤を含む洗剤は絶対に使用しないでください。



Replaceability & Energy Efficiency Class



DA
Dette produkt indeholder en lyskilde i energieffektivitetsklasse E

EN
This product contains a light source of energy efficiency class E

DE
Dieses Produkt enthält eine Lichtquelle der Energieeffizienzklasse E

SV
Denna produkt innehåller en ljuskälla med energieffektivitetsklass E

IT
Questo prodotto contiene una sorgente luminosa di classe di efficienza energetica E

FR
Ce produit contient une source lumineuse de classe d'efficacité énergétique E

ES
Este producto contiene una fuente luminosa de la clase de eficiencia energética E

FI
Tämä tuote sisältää valonlähteen, jonka energiatehokkuusluokka on E

JP
この製品はエネルギー効率クラスEです

KR
이 제품은 에너지 효율 등급 E를 받았습니다.

CN
本产品包含能效等级 E.



DA
Lyskilden i dette armatur må kun udskiftes af producenten eller en uddannet elektriker. Forstærket isolation mellem LV-forsyning og styrelederne. Hvis den eksterne fleksible ledning eller kablet til dette armatur beskadiges, skal det udskiftes af producenten, dennes servicerepræsentant eller en person med tilsvarende kvalifikationer for at undgå farlige situationer.



EN
The light source contained in this luminaire must only be replaced by the manufacturer or a qualified electrician. Reinforced insulation between LV supply and control. If the external flexible cable or cord of this luminaire is damaged, it must only be replaced by the manufacturer or his service agent or a similar qualified person in order to avoid hazardous situations.



DE
Das in dieser Leuchte enthaltene Leuchtmittel sollte nur vom Hersteller oder von einem qualifizierten Elektriker ausgetauscht werden. Verstärkte Isolierung zwischen Niederspannungsversorgung und Regler. Im Fall einer Beschädigung des externen flexiblen Leuchtenkabels darf der Austausch des Kabels aus Sicherheitsgründen ausschließlich durch den Hersteller oder eine vom Hersteller benannte Servicestelle oder eine Fachkraft mit geeigneter Qualifikation erfolgen.



SV
Ljuskällan i denna armatur ska endast bytas ut av tillverkaren eller en kvalificerad elektriker. Förstärkt isolering mellan lågspänningskälla och strömbrytare. Om den externa flexibla ledningen till armaturen skadas ska den endast bytas ut av tillverkaren eller dennes servicerepresentant eller liknande kvalificerad person för att undvika fara.



IT
La sorgente contenuta in questa parte illuminante sarà solo riposizionata dal produttore o da un elettricista esperto. Isolamento rinforzato tra alimentazione e controllo LV. Se il cavo esterno flessibile dell'apparecchio è danneggiato, dovrà essere sostituito esclusivamente dal produttore, dal servizio assistenza o da personale qualificato per evitare qualsiasi pericolo.



FR
La source lumineuse de ce luminaire ne peut être remplacée que par le fabricant ou un électricien qualifié. Isolation renforcée entre l'alimentation basse tension et la commande. Si le cordon ou le câble flexible externe de ce luminaire est endommagé, il doit être exclusivement remplacé par le fabricant, son représentant ou une personne qualifiée afin d'éviter tout danger.



ES
La sustitución de la fuente de luz que contiene esta luminaria debe ser llevada a cabo exclusivamente por el fabricante o un electricista profesional. Aislamiento reforzado entre fuente de baja tensión y control. Si el cable flexible externo de esta luminaria se dañara, debería ser reemplazado únicamente por el fabricante, o por su agente autorizado, o por una persona cualificada para así evitar peligros.



FI
Tämän valaisimen valonlähteen saa vaihtaa ainoastaan valmistaja tai koulutettu sähköasentaja. Vaarallisten eristys pienjännitteen syötön ja ohjauksen välillä. Vaarallisten välitöiden välttämiseksi valaisimen vahingoittuneen ulkoisen joustavan kaapelin tai johdon saa vaihtaa vain valmistaja, valtuutettu huoltoliike tai vastaava pätevä taho.



JP
この照明器具のLEDは、一般のランプのように取り換えができません。不点の場合は当社にお問い合わせください。取り外し、取り付けのときは、必ず電源を切ってください。感電のおそれがあります。この照明器具のケーブルやコードが損傷した場合、速やかに電源を切り、当社または販売店にご相談ください。



KR
이 등기구에 포함된 광원은 제조업체 또는 자격을 갖춘 전기기사만이 교체할 수 있습니다. LV 전원과 제어 장치 사이의 절연 보강. 이 조명 기구의 외부 플렉서블 케이블이나 코드가 파손된 경우, 위험을 방지하기 위해 제조업체 또는 제조업체가 지정한 서비스 대리인이나 기타 자격을 갖춘 사람에게 의해서만 교체되어야 합니다.



CN
此灯具中的光源只能由制造商或具备相应资格的电工进行更换。加强低压电源和控制之间的绝缘。如果此灯具的外部软电缆或软线损坏，应由制造商、其服务代理或类似的具备相应资格的人员进行更换，避免发生危险。

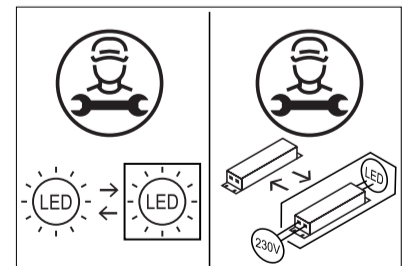

LOUIS POULSEN A/S
KUGLEGAARDSVEJ 19-23,
1434 COPENHAGEN K, DENMARK
TEL. +45 70 33 14 14
INFO@LOUISPOULSEN.DK
WWW.LOUISPOULSEN.COM



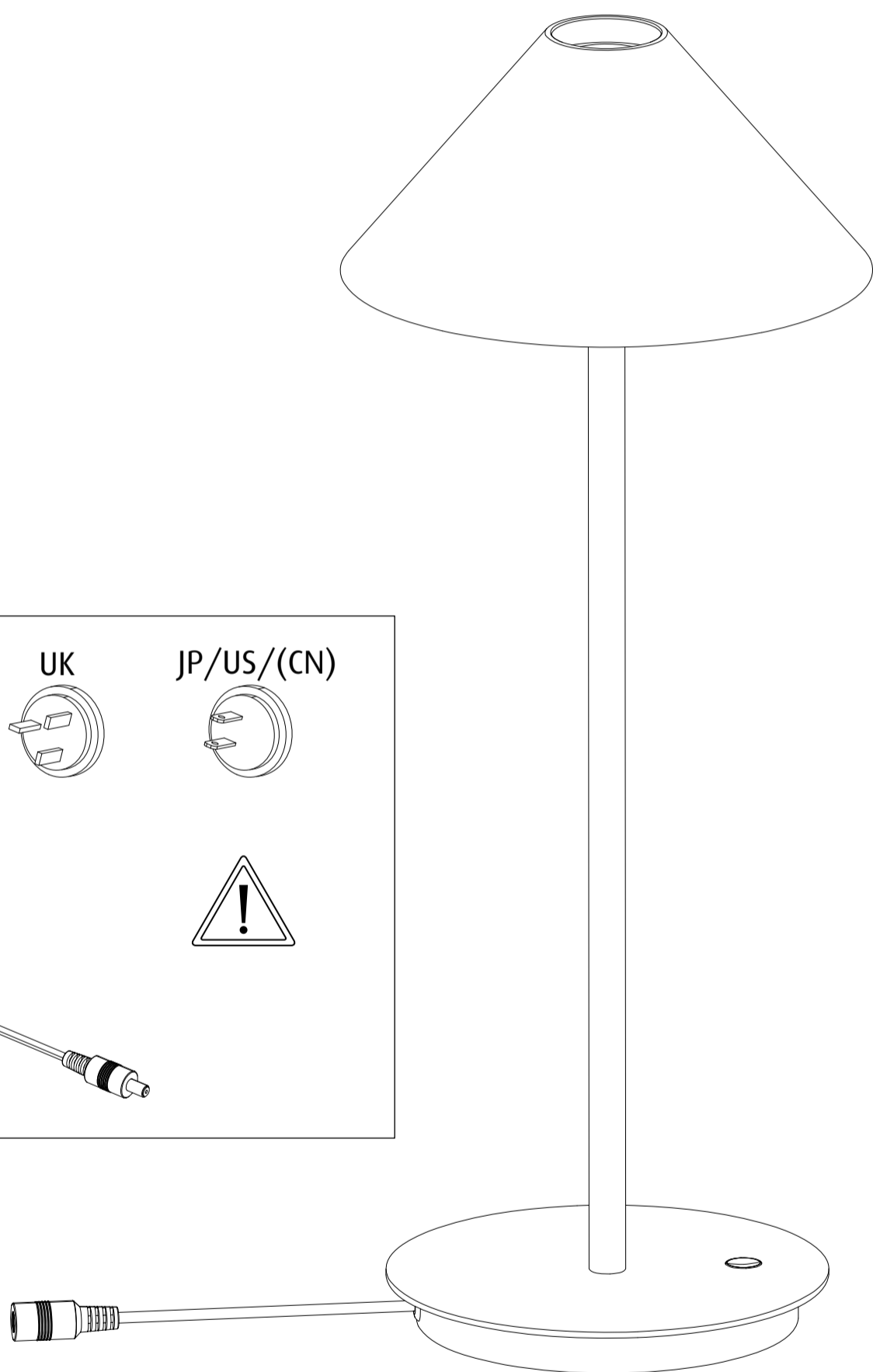
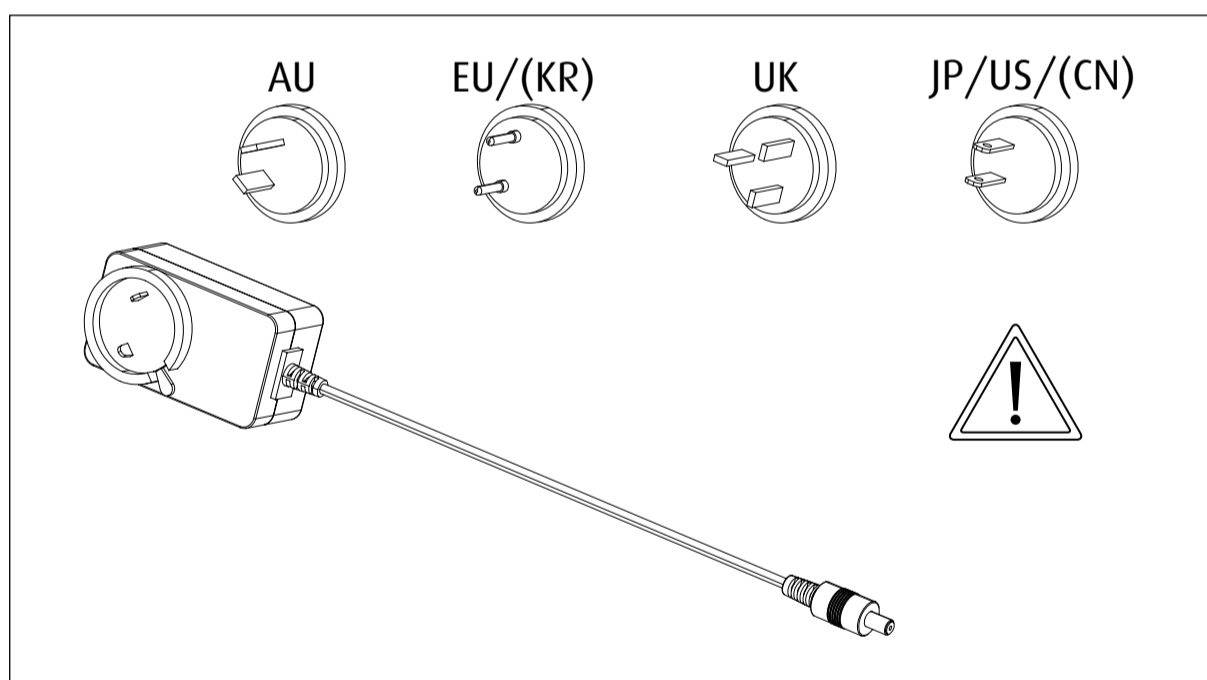
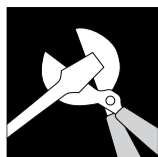

Keglen Table Base - Electronic Functions

Mounting Instruction Version 2

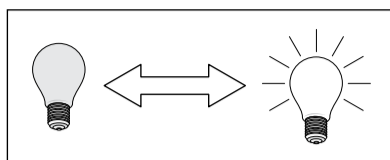

Light on/off:

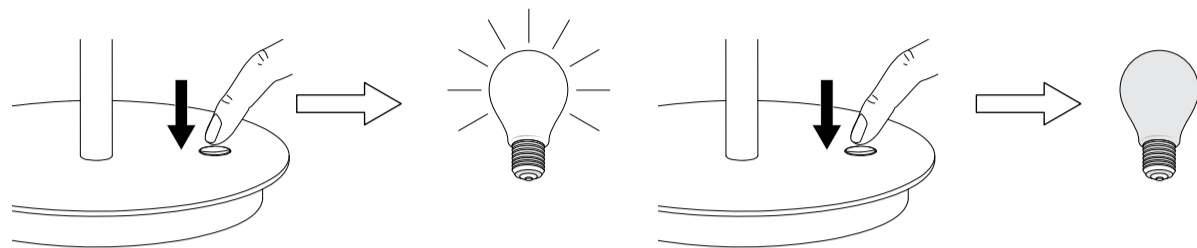

Dimming Function:

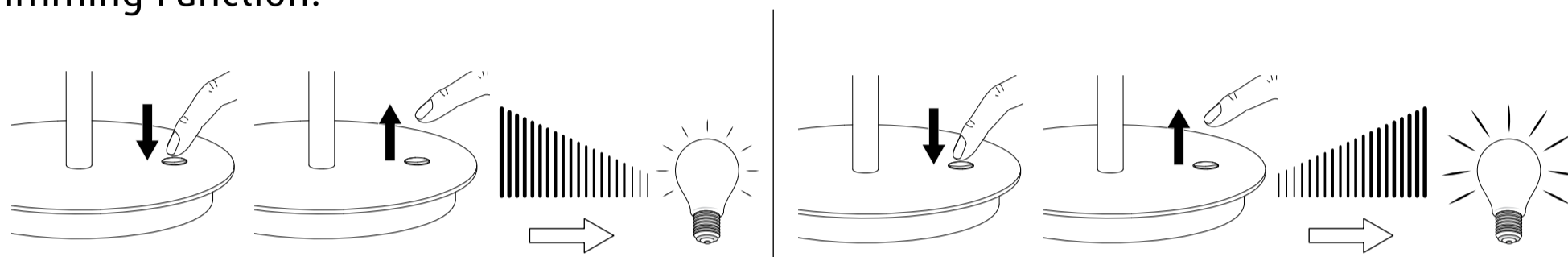

Additional User Settings

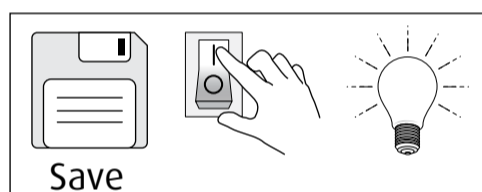

A Lock on/off Button Function

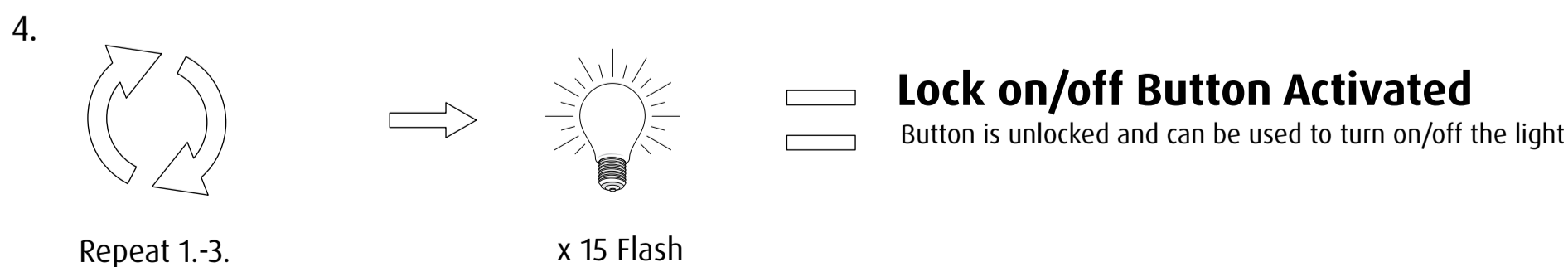
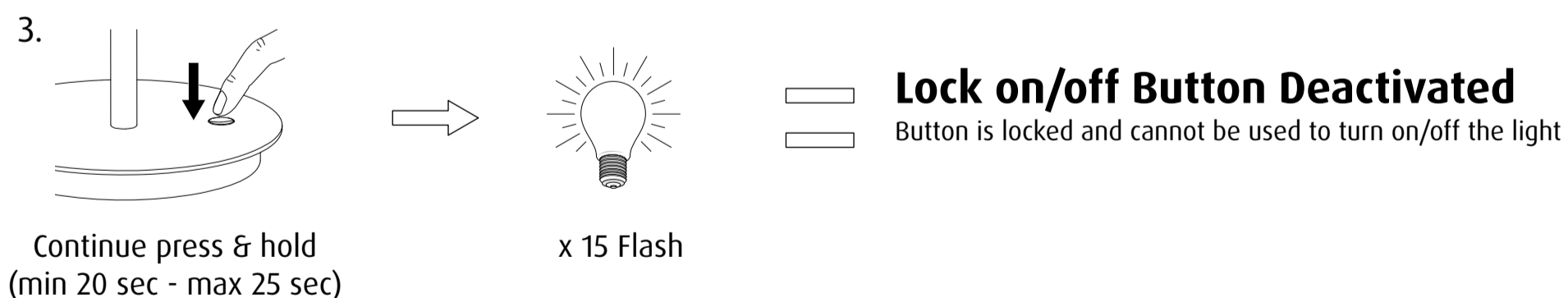
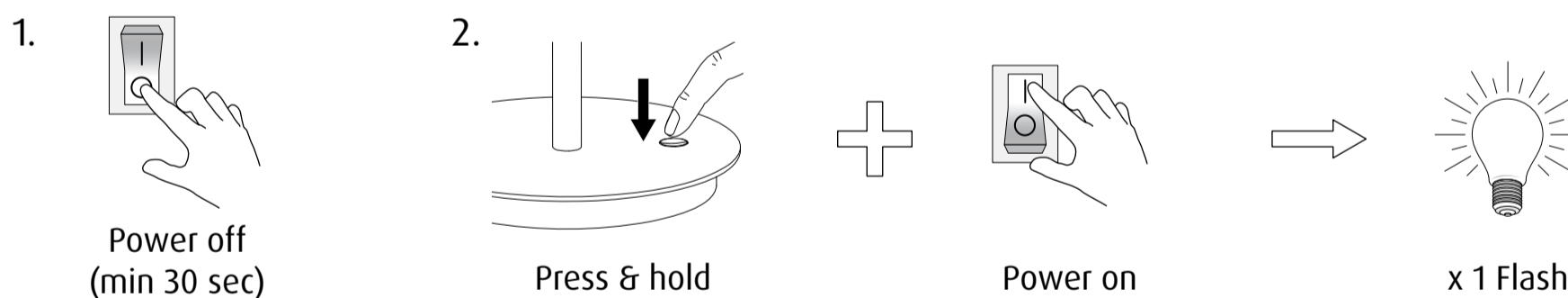

Keglen Table Base - Electronic Functions

Mounting Instruction Version 2

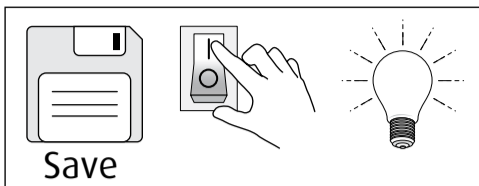

B Set default brightness level (User Function) Factory reset to deactivate brightness level when set

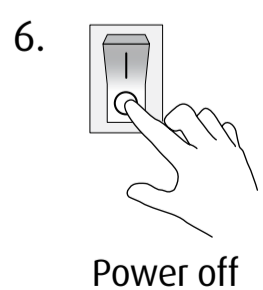
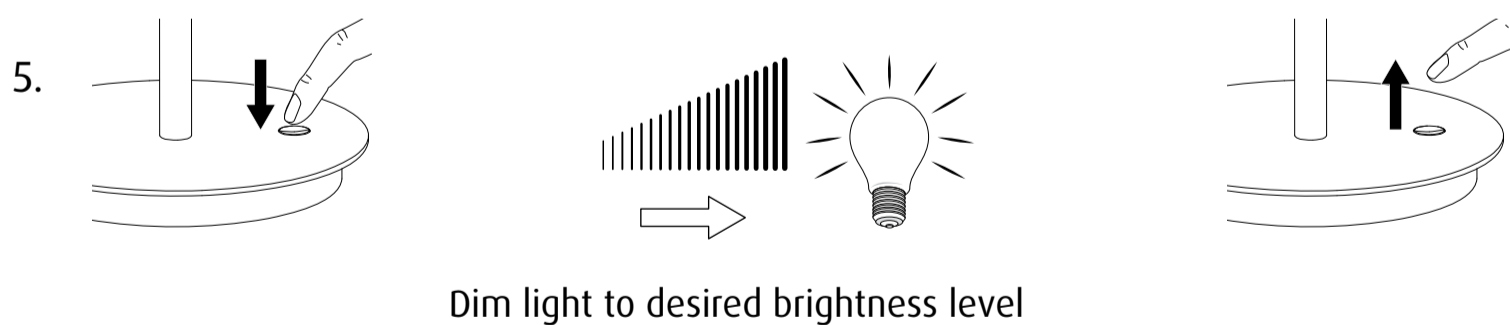
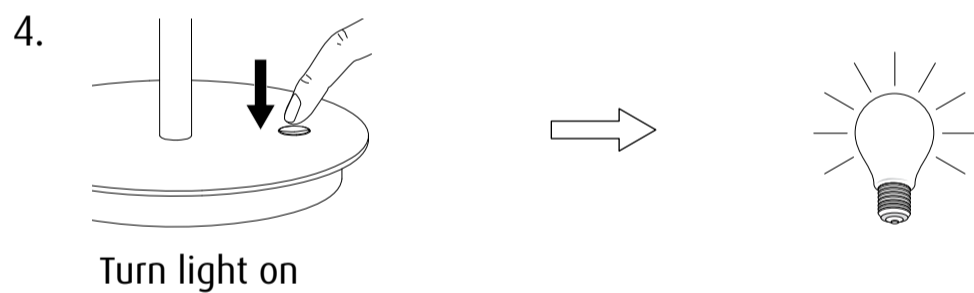
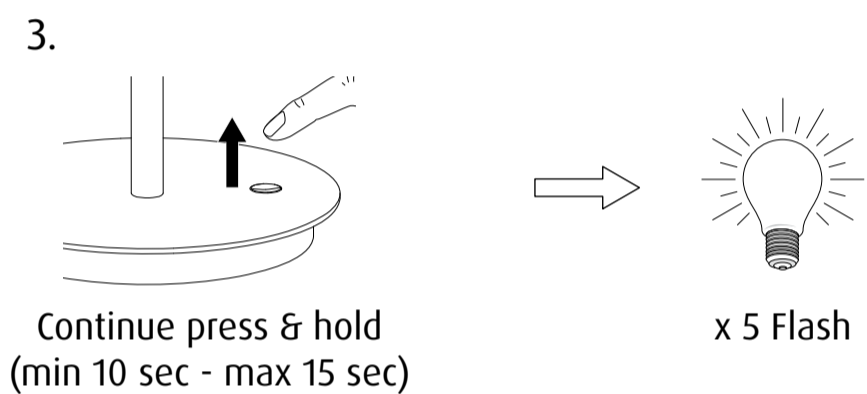
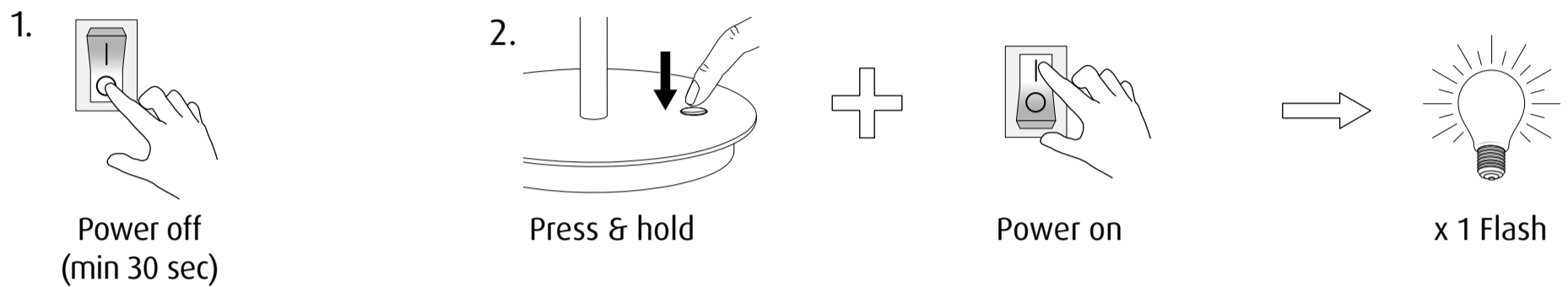

Keglen Table Base - Electronic Functions

Mounting Instruction Version 2

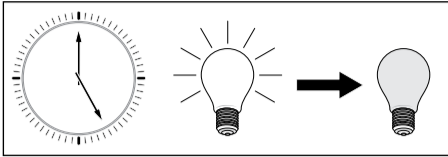

C Timing Function (User Function)

Set timer to automatically turn off after period of time

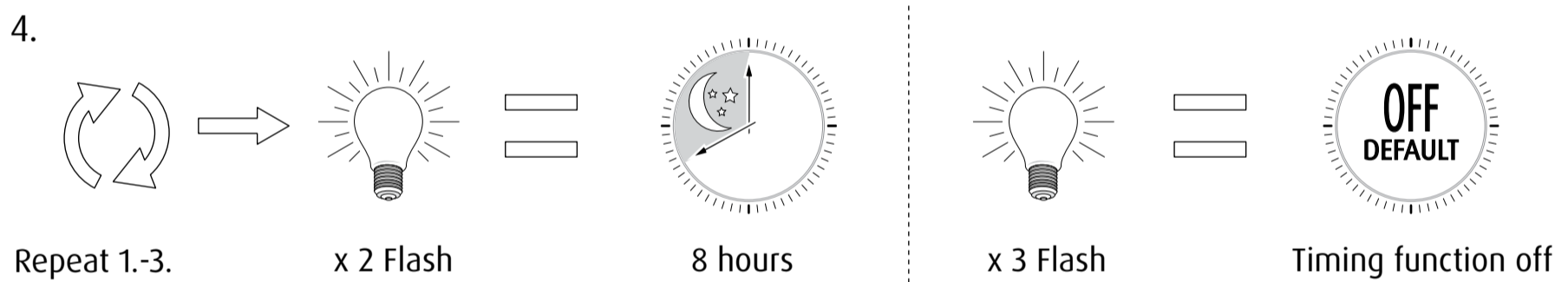
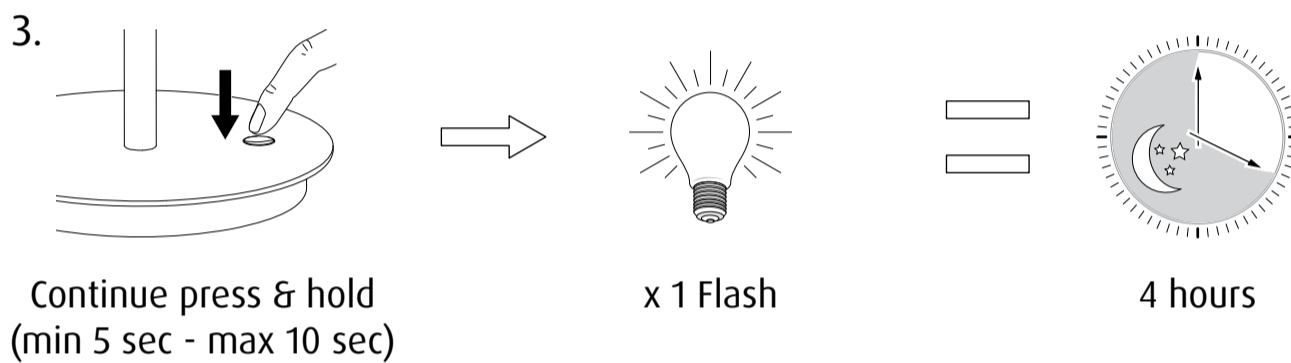
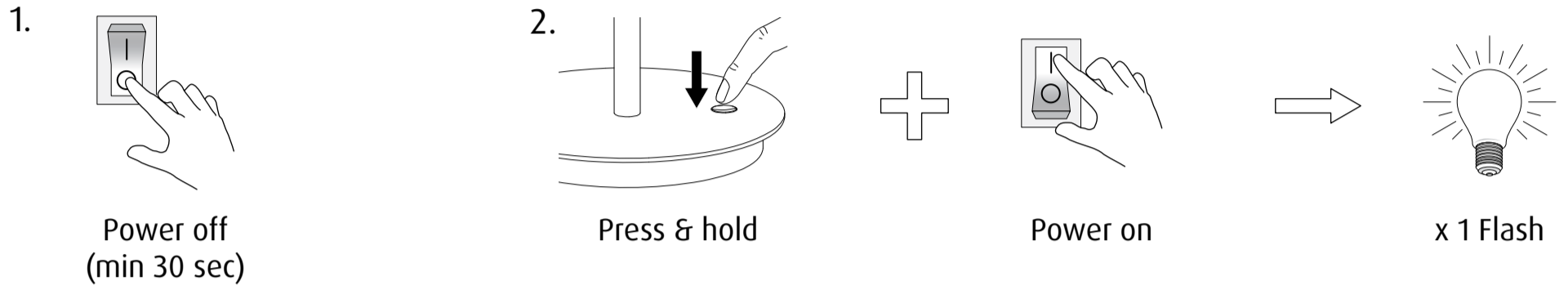

D Dimming Function: Deactivate (User Function)

Factory reset to activate dimming function

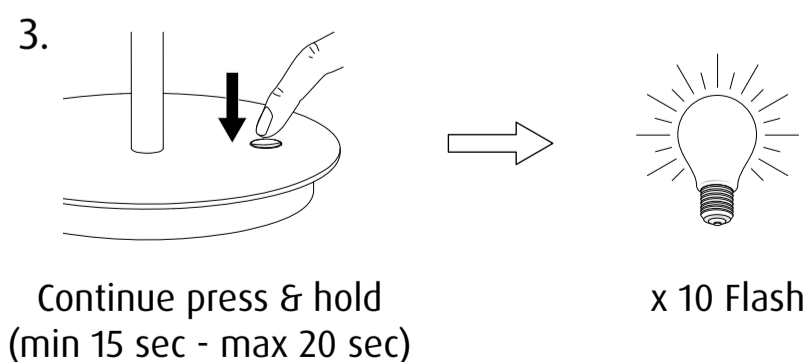
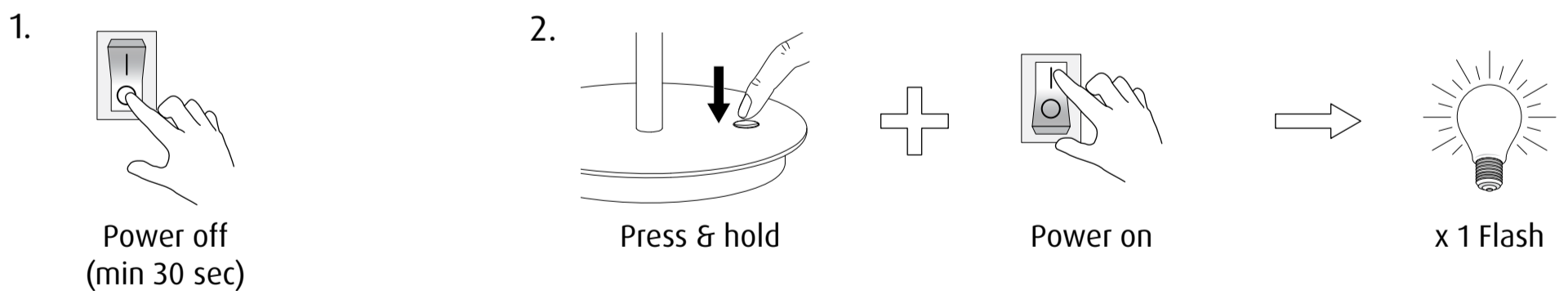

Keglen Table Base - Electronic Functions

Mounting Instruction Version 2

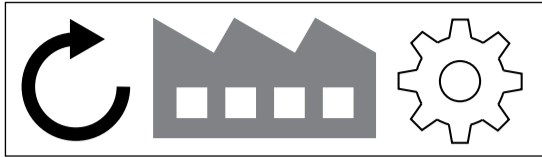

Restore factory default settings:

This is the standard setting for this product.

With this setting the on/off button and dimming function is active.

