

**INSTRUCTION MANUAL FOR 45W HEX DRIVE
MODEL NO.: HED1045 + SAM8 / SAM11**

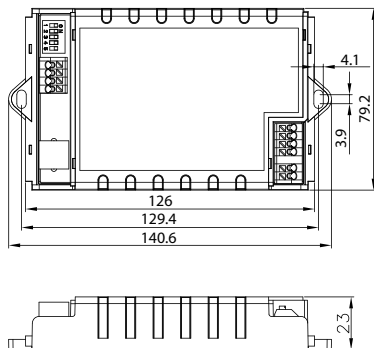
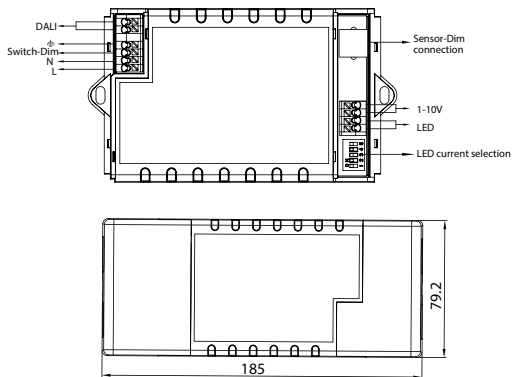

additional cap for standalone installation

HF Sensor Antenna

Model: SAM8

Detection range (DxH): 12 x 6 m

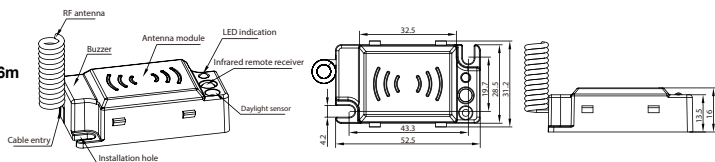

HF Sensor Antenna (with rotary switch for fast grouping)

Model: SAM11

Detection range (DxH): 12 x 6 m

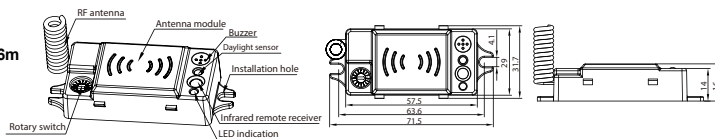

HIGHLIGHTS

- Standby power < 0.5W
- Flicker-free dimming from 100%~30%
- In compliance with DALI 2 standard.
- DALI and switch-Dim can be used at the same time.
- Automatic output reduction 80%~60%~40%~20% against overheat
- Failure DALI feedback

LED CURRENT SELECTION

The current can be easily configured by choosing the correct combination of the DIP switches (see table below):

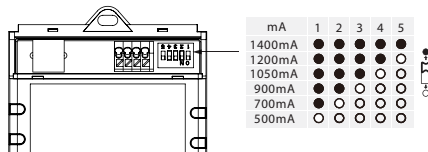

RF Grouping via Rotary Switch (for SAM11)

15 channels are available for fast grouping via rotary switch on the RF sensor antenna, simply selecting the same channel on each unit, the grouping is automatically completed.

Noted:channel "0" is not for fast grouping, and sensors can only be grouped by remote control.



SECTION 1 INSTALLATION AND WIRING

Switch-Dim Wiring Diagram

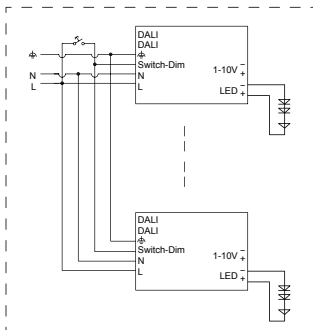

1-10V Wiring Diagram

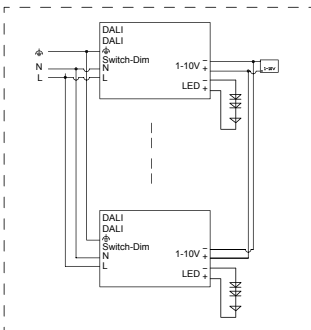

DALI + Switch-Dim Wiring Diagram

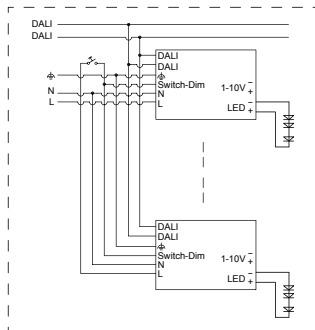

Warning: Please make sure the correct current is selected before starting the driver!

SECTION 2 FUNCTION

2.1 Functions for driver only (without sensor head)

Switch-dim



- On/off control: short push (<0.4s) on the switch.
Note: Short push should be at least 0.12s, and the time interval between two pushes should be longer than 0.12s also.
- Stepless dimming: long push (>0.9s) on the switch.
- For fine tuning of light level: with every alternate long push, the light level goes to the opposite direction.
- Built-in permanent memory: light returns to the previous dimming level when switched off and on again, even after power failure.

Synchronization

Up to 64 drivers can be connected to the same switch, thanks to the programme. This means there is no need for any additional synchrony wire in large installation, where many drivers should be controlled by one switch.

Please follow the step below to achieve synchronization function if more than one driver is connected to the same push button:

- Do a long push for more than 15s, then the system is synchronized and all lights in the group dim down to 50%.

Permanent Memory

This driver has built-in permanent memory against power failure, which means the light always starts up at the previous level when it was switched off last time.

Manual Override

DALI and switch-Dim. can be connected at the same time, to enable manual override function for end-users to switch on/off or adjust the dimming level by the push-switch. This feature makes the product more user-friendly, and could provide more options for some extra-ordinary demands.

- Short push (<0.4s): on/off control.
- Long push (>0.9s): dim up/down the dimming level.
- If customers do not want to have this manual override function, just leave the "switch" terminal alone, and not connected to any wire.
- This manual override is only valid before the next DALI command, meaning the latest action, either from DALI, switch-Dim, stays in control.

2.2 Functions for sensor only (with sensor head)

Daylight Monitoring Function

Hytronik specially designed this function in software for deep energy-saving purpose. A built-in daylight sensor is designed to provide "smart photocell" function. This function can only be activated when stand-by period is set to "+∞". In this mode the lamp will automatically illuminate at the dim level setting when the natural light goes below the threshold setting. The fixture will also switch off as the natural light returns.

Manual Override

This sensor reserves the access of manual override function for end-user to switch on/off, or adjust the brightness by push-switch, which makes the product more user-friendly and offers more options to fit for some extra-ordinary demands:

* Short push (<1s): on/off function;

On → off: the light turns off immediately and can not be lighten for a certain time (equals to hold-time preset) even movement is detected.

After this period, the sensor goes to sensor mode.

Off → on: the light turns on and goes to sensor mode, no matter if ambient Lux level exceeds the daylight threshold or not.

* Long push (>1s): dim up/down the hold-time brightness between 10% and 100%.

Note: if end-user do not want this manual override function, just leave the "push" terminal alone and don't connect it to any wire.

SECTION 3 REMOTE CONTROL

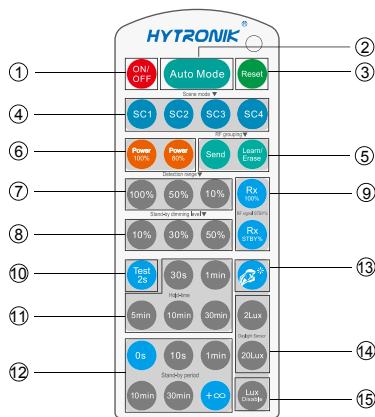

HRC-04

Note: the buzzer beeps one time when RC receives signal successfully

Permanent ON/OFF [button ①]

Press button ① to select permanent on or permanent off mode, sensor is disabled.

* Press buttons ② ③ ③ to resume automatic operation.

Auto Mode [button ②]

Press button ② to initiate automatic mode. The sensor starts working and all settings remain as before the light was switched on/off.

RESET [button ③]

Press button ③, all settings go back to default settings:

Detection range: 100%; Hold-time: 1min; Stand-by period: 5min;
Stand-by dimming level: 20%; Daylight sensor: Lux disable; Rx 100%

Power output [button ⑥]

Press buttons ⑥, the output shifts between 80% and 100%, for energy saving purpose.

Brightness on RF signal [button ⑦]

Press button ⑦, the light(s) on slave is 100% on upon receiving RF ON signal; Press "Rx STBY%" button, the light(s) goes to pre-set stand-by dimming level directly.

Test 2s function [button ⑩]

Press button ⑩, the sensor goes into test mode (hold-time is 2s). The stand-by period and daylight sensor settings are disabled in test mode.

* Press button ③ ③ ① to exit from this mode and the sensor settings are changed accordingly.

Ambient daylight threshold [button ⑬]

Press button ⑬, the latest surrounding lux value overwrites previous lux value learned, and is set as the daylight threshold.

Lux disable [button ⑮]

Press button ⑮, the built-in daylight sensor is disabled, the light will always operate upon detection, regardless of ambient light level.

Detection range [zone ⑦]

Press buttons in zone ⑦ to set detection range at 10% /50% /100%.

Hold time [zone ①]

Press buttons in zone ① to set hold time at 30s / 1min / 5min / 10min / 30min.

Daylight sensor [zone ②]

Press buttons in zone ② to set daylight sensor at 2lux / 20lux.

Stand-by period [zone ③]

Press buttons in zone ③ to set the stand-by period at 0s / 10s / 1min / 10min / 30min / +∞ .

Note: "0s" means on/off control; "+∞" means bi-level control, the light will never switches off when daylight sensor is disabled.

Stand-by dimming level [zone ④]

Press buttons in zone ④ to set the stand-by dimming level at 10% / 30% / 50% .

RF grouping [zone ⑤]

Short press "Learn/Erase" button on RC to activate pairing mode, and the receiver unit will beep once every second for 3min.

Note: the unit can only pair up to 30 units.

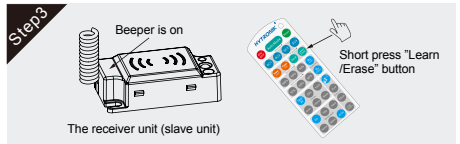
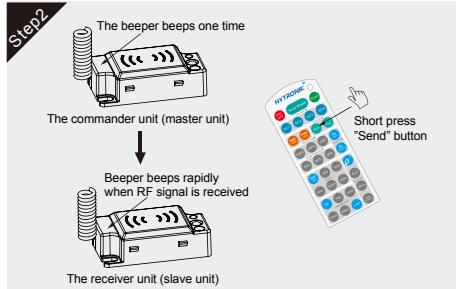
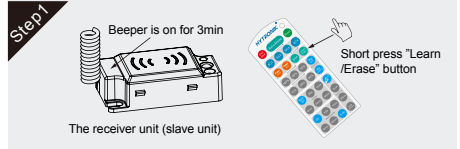
**Erase:**

Long press "Learn/Erase" button for 3s, and the receiver unit clears all commands it has received before.

The beeper rapidly beeps for about 5s. This is the indication of a successful reset and previous groupings are all erased.

SECTION 4 SPECIFICATION

Mains voltage	220~240VAC 50/60Hz		
Mains current	0.22 ~ 0.2A		
Max. output power/current/voltage	28W / 500mA / 12 ~ 56V 45W / 1050mA / 12 ~ 42V	40W / 700mA / 12 ~ 56V 40W / 1200mA / 12 ~ 34V	45W / 900mA / 12 ~ 50V 40W / 1400mA / 12 ~ 28V
Output voltage (U-out max.)	75V		
Power factor	≥0.95		
Operation temperature	Ta: -20~+45℃ Tc:+85℃		
Max. Efficiency	87%		
Dimming interface	DALI, Switch-Dim., 1-10V		
Dimming range	1~30% PWM dimming; 30~100% analogue dimming.		
Stand-by power consumption	<0.5W		
Abnormal protection	Output short-circuit protection with auto-reset		
Over-heat protection	Over-heat protection with auto-reset		
EMC standard	EN55015, EN61547, EN61000-3-2/3		
Safety standard	EN61347-1, EN61347-2-13, EN60598-1		
DALI standard	IEC62386-101,102,207		
Dielectric strength	Input → output : 3750VAC		
IP grade	IP20		