

SMARTCHR 5454089 Smart compensator

The SMARTCHR module is designed for operation with the YOKIS 500 range products (WIRED and RADIO).

The SMARTCHR reduces the minimum load power required by the dimmer for correct operation particularly in the case of LED, fluorescent or energy saving lights.

The SMARTCHR module reduces flickering and guarantees the complete shutdown of the lights.

Specifications:

- Mains voltage: 230V ~ (+10% -15%) - 50Hz
- Ambient temperature: 20°C + 40°C
- Relative humidity: 0 to 90%
- Dimensions: 20 x 16 x 11 mm.
- Module consumption: < 1.04 W



WARNINGS

The SMARTCHR module is provided with wires and without terminal board. In-line terminals or similar connectors must be used to wire to the electrical network. The module must be installed complying with the rules in force in the country in which it is sold. The module must only be installed by qualified personnel in accordance with national installation regulations.

The device must be connected to a line protected upstream by a C-curve 10A circuit breaker.

The maximum number of SMARTCHR modules that can be installed on a single load must not be higher than 3.

If multiple SMARTCHR modules are installed in the same box, a free clearance of 300 cm³ must be provided for each module

INSTALLATION

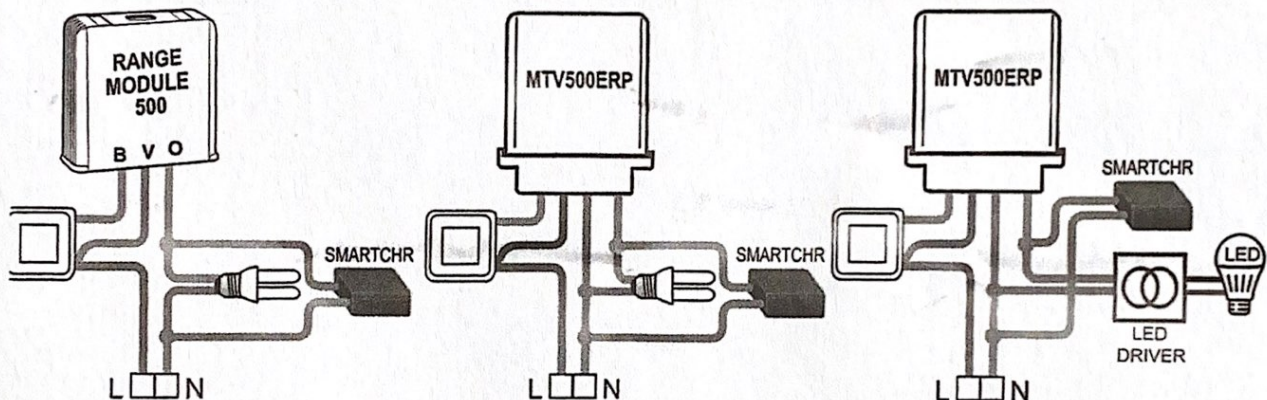

INFORMATION



DIRECTIVE 2012/19/EU OF THE EUROPEAN PARLIAMENT AND OF THE COUNCIL of 4 July 2012 on waste electrical and electronic equipment (WEEE)

The symbol of the crossed-out wheeled bin on the product or on its packaging indicates that this product must not be disposed of with your other household waste. Instead, it is your responsibility to dispose of your waste equipment by handing it over to a designated collection point for the recycling of waste electrical and electronic equipment. The separate collection and recycling of your waste equipment at the time of disposal will help to conserve natural resources and ensure that it is recycled in a manner that protects human health and the environment. For more information about where you can drop off your waste equipment for recycling, please contact your local city office, your household waste disposal service or the shop where you purchased the product.

Urmet S.p.a. – 10154 TORINO (ITALY) – Via Bologna 188/C

For technical information, go to www.yokis.com or call:

Customer Service: +39 011.23.39.810 - Export Dept. Phone: +39 011.24.00.250/256 - Fax: +39 011.24.00.296

WARRANTY: In addition to the warranty required by law, this product is guaranteed for 5 years from date of manufacture. The material must be used according to the instructions provided and for its intended use. Faults must not be caused by deterioration or accidents resulting from negligence, anomalous use or incorrect installation. In all cases, the warranty only includes replacement of faulty products. No compensation for loss or damage may be claimed.