

COBUS

last update 25/01/2022

BEL1047

Cobus A : code 1134.G9._ _ max.5W G9 LED (max. diameter 20mm / height 65mm) - 220/240V
 Cobus B : code 1138.G9._ _ max.5W G9 LED (max. diameter 20mm / height 65mm) - 220/240V
 Cobus C : code 1135.G9._ _ max.5W G9 LED (max. diameter 20mm / height 65mm) - 220/240V
 Cobus D : code 1137.G9._ _ max.5W G9 LED (max. diameter 20mm / height 65mm) - 220/240V



Cobus A : code 1134.W40._ _ LED 3W - 2700K - 220/240V
 Cobus B : code 1138.W40._ _ LED 3W - 2700K - 220/240V
 Cobus C : code 1135.W40._ _ LED 3W - 2700K - 220/240V
 Cobus D : code 1137.W40._ _ LED 3W - 2700K - 220/240V

Cobus A

∅ 142mm

∅ 100mm

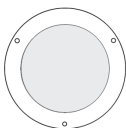

Cobus B

∅ 142mm

∅ 100mm

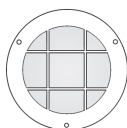

Cobus C

∅ 142mm

∅ 100mm

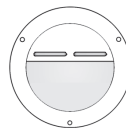

Cobus D

∅ 142mm

∅ 100mm

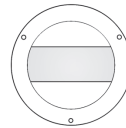

ATTENTION - WARNING

The luminaire should be installed and connected by a qualified technician.
 Le luminaire doit être installé et connecté par un technicien qualifié

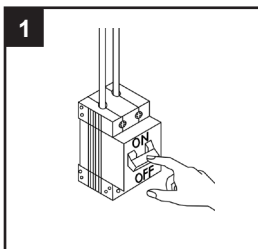

INSTALLATION INSTRUCTIONS - PART A

1. Before accessing any parts carrying live voltage, the power must be disconnected
Avant tout accès à des parties sous tension, la tension doit être coupée
Placer le luminaire
2. Place the luminary
Placer le luminaire
3. Make the electrical connection
Faire la connexion électrique
4. Close the light
Fermer le luminaire
5. Switch on
Allumer

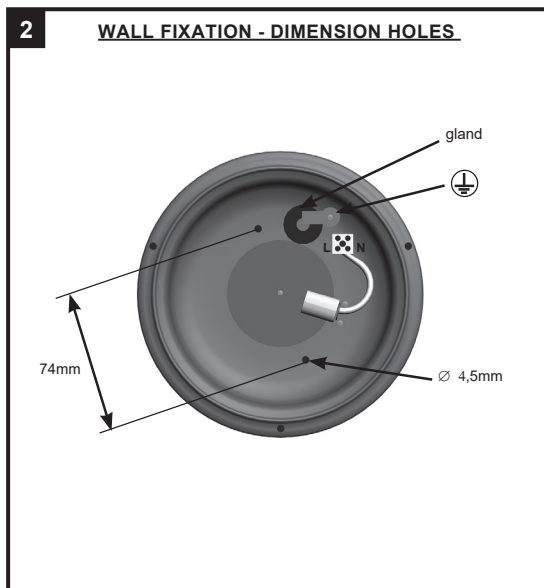

see next page →

BEL LIGHTING

BEL LIGHTING sprl
 Avenue Ernest Solvay 42
 B-1480 Saintes (Tubize)
 Belgium
 Phone: +32(0)2 3552428
 Fax: +32(0)2 3550396
 e-mail: info@bel-lighting.com
 www.bel-lighting.com

PART

A

Lees de algemene gebruiksvoorwaarden : PART B
 Lire attentivement les conditions générales d'utilisation: PART B
 Read attentively the general instructions: PART B
 Lesen Sie die allgemeinen Gebrauchsanweisungen: PART B
 Διαβάστε της γενικές οδηγίες : PART B

WAARSCHUWING
 AVERTISSEMENT
 WARNING
 WARNUNG
 ΠΡΟΣΟΧΗ

COBUS

last update 25/01/2022

BEL1047



BEL LIGHTING sprl
Avenue Ernest Solvay 42
B-1480 Saintes (Tubize)
Belgium
Phone: +32(0)2 3552428
Fax: +32(0)2 3550396
e-mail: info@bel-lighting.com
www.bel-lighting.com



Correcte verwijdering van dit product (Elektrische&elektronische afvalapparatuur)
Comment éliminer ce produit (Déchets d'équipements électriques&electroniques)
Korrekte Entsorgung dieses Produkts (Elektromüll)
Correct disposal of this product (Waste electrical&electronical equipment)

ACCESSORY SET

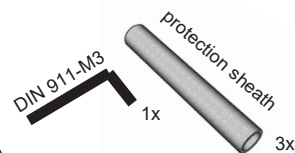

3

IMPORTANT : Gland for cable \varnothing 3 ---> 9mm

- NL - Het einde van de wartels horizontaal insnijden (zeker niet in kruis)
- FR - Couper le bouchon horizontalement à l'extrémité. (ne surtout pas couper en croix X)
- EN - Cut horizontally the end of the gland (certainly not cut in cross)
- DE - Das Oberteil der Kabelverschraubungen horizontal abschneiden (sicher nicht in Kreuz (X))
- EL - Περικοπή οριζόντια το τέλος του αδένα (βεβαιώς που δεν κοβεται στο σταυρο X)

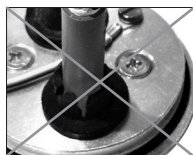
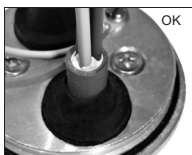
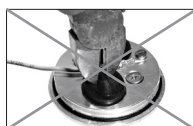

ELECTRICAL CONNECTION

- NL - Voeg de voedingskabel in de beschermingskoker
- FR - Insérer le câble d'alimentation dans la gaine de protection.
- EN - Insert the feeder in the protection sheath
- DE - Das Kabel in die Schutzhülle einfügen
- EL - Παρεμβαλάτε τον τροφοδοτή στη θήκη προστασίας

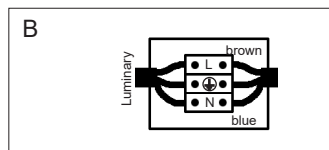
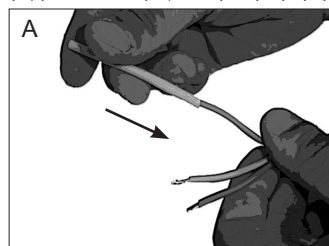

4

- NL - Maak de schroeven steeds allemaal geleidelijk los of vast: schroef dus nooit 1 vijs helemaal los of vast, maar schroef alle schroeven diagonaal beetje bij beetje los of vast.
- FR - Bloquer et débloquer les vis de fermeture "en croix", par séquence alternée, comme sur la figure.
- EN - Lock and unlock the screws following an alternate sequence.
- DE - Die Verschlusschrauben kreuzweise anziehen bzw. lösen.
- EL - Κλειδώστε και ξεκλειδώστε τις βίδες ακολουθώντας έναν εναλλακτικό τρόπο.

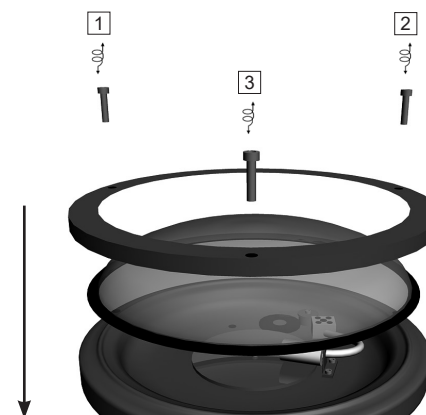

PART

A

Lees de algemene gebruiksvoorwaarden : PART B
Lire attentivement les conditions générales d'utilisation: PART B
Read attentively the general instructions: PART B
Lesen Sie die allgemeinen Gebrauchsanweisungen: PART B
Διαβάστε της γενικές οδηγίες : PART B

WAARSCHUWING
AVERTISSEMENT
WARNING
WARNUNG
ΠΡΟΣΟΧΗ