

CONNESSIONE PER DIMMERAZIONE PUSH
PUSH DIMMING CONNECTION

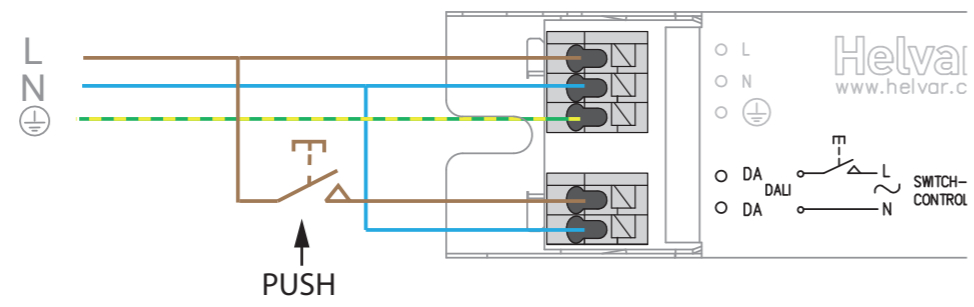

Istruzioni per il montaggio
Assembly instructions
Instructions pour le montage
Montageanleitung
Instrucciones para el montaje

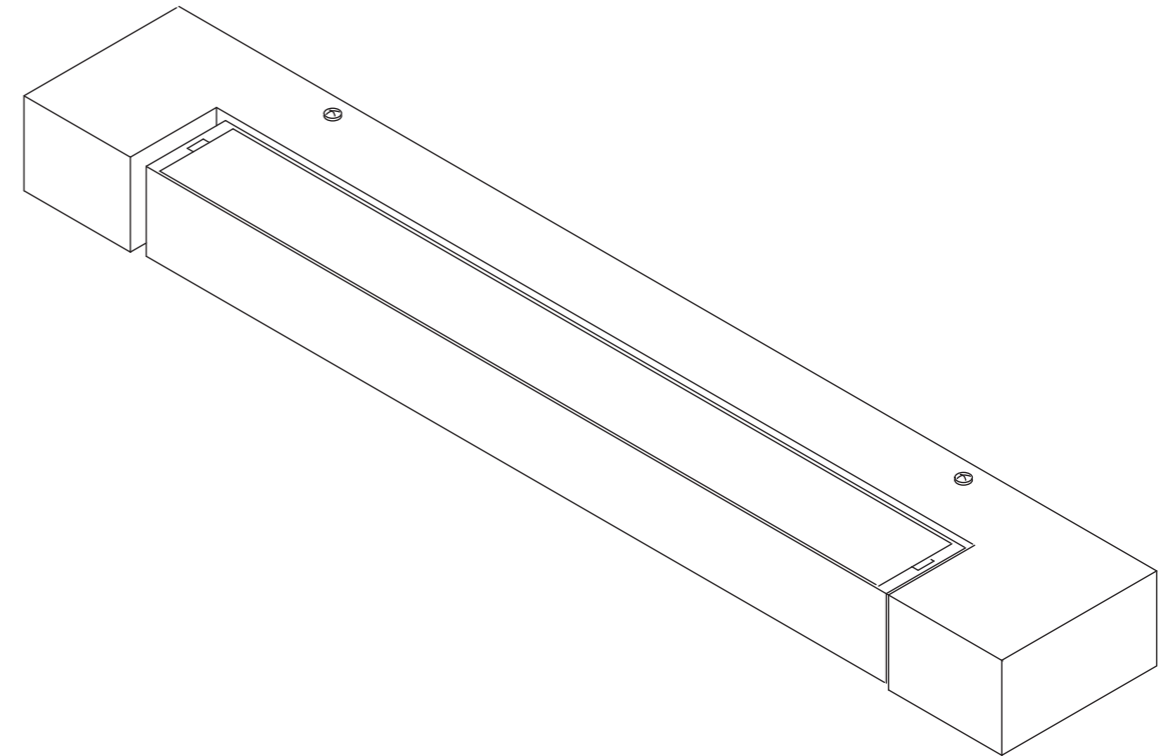

Design Ilaria Marelli
Ara Parete 69 LED



LED 34 W - 4000 lm - 230V



- ITALIANO:** Le descrizioni dei simboli relativi a questa lampada si trovano sul foglio allegato.
- ENGLISH:** Descriptions of the symbols for this lamp can be found on the sheet enclosed.
- FRANÇAIS:** Les descriptions des symboles relatifs à cette lampe se trouvent sur le document ci-joint.
- DEUTSCH:** Die Beschreibungen für die Symbole, die auf diese Lampe bezogen sind, entnehmen Sie bitte dem beiliegenden Zettel.
- ESPAÑOL:** Las descripciones de los símbolos relativos a esta lámpara se encuentran en el folio adjuntado.
- БЪЛГАРСКИ:** Описанията на символите за тази лампа са в приложението лист.
- ČEŠTINA:** Popisy symbolů pro tuto lampu naleznete na příloženém listě.
- DANSK:** Beskrivelsen af de symboler, som angår denne lampe, findes på den vedlagte forklaring.
- EESTI:** Selle lambi kohta käivate sümbolite kirjeldused leiata kaasasolevalt lehel.
- ΕΛΛΗΝΙΚΑ:** Τα σύμβολα του φωτιστικού αυτού περιγράφονται στο συνημμένο φυλλάδιο.
- HRVATSKI:** Opisi simbola koji se odnose na tu svjetiljku, nalaze se na priloženom listu.
- LATVISKI:** Šīs lampas simbolu apraksts ir pievienotajā lapā.
- LIETUVIŲ:** Šios lempos simbolių aprašymai pateikiami pridėjame lape.
- MAGYAR:** A lámpával kapcsolatos jelek leírását lásd a mellékelt tájékoztatót.
- NEDERLANDS:** De beschrijving van de symbolen m.b.t. deze lamp bevindt zich op het blad in bijlage.
- NORSK:** Forklaringene på symbolene som gjelder for denne lampen finnes på vedlagte ark.
- POLSKI:** Opisy symboli dotyczących tej lampy zostały przytoczone w załączonej ulotce.
- PORTUGUÊS:** As descrições dos símbolos relativos a esta lâmpada encontram-se na página em anexo.
- ROMÂNĂ:** Descrierea simbolurilor referitoare la această lampă se găsește în foaia atașată.
- SLOVENSKI:** Opisi simbolov, ki se nanašajo na to svetilko, so na priloženem listu.
- SLOVENČINA:** Popis symbolov pre túto lampu je uvedený na priloženom hárku papiera.
- SUOMI:** Tätä lampua koskevien symbolien selitykset löytyvät oheisesta liitteestä.
- SVENSKA:** Beskrivningarna av symbolerna som gäller denna lampas finns att läsa på det bifogade informationsbladet.

-Questo dispositivo è munito di sorgenti a LED integrate
 -This device is equipped with integrated LED bulbs
 -Cet appareil est équipé avec des lampes LED intégrées
 -Dieses Gerät ist mit einer integrierten LED-Leuchte ausgestattet
 -Este dispositivo está equipado con lámparas de LED integradas

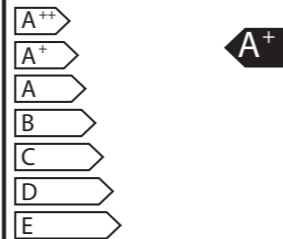

Le lampadine di questo dispositivo non sono sostituibili

The bulbs of this device are not replaceable

Les lampes de ce dispositif ne sont pas remplaçables

Die Zwiebeln von diesem Gerät sind nicht austauschbar

Las lámparas de este dispositivo no son reemplazables

874/2012



L'apparecchio d'illuminazione che Lei ha acquistato è garantito per 24 mesi dalla data dell'acquisto contro difetti estetici e funzionali. In caso di reclamo restituisca al Suo fornitore l'apparecchio con lo scontrino di cassa o la fattura comprovante la data d'acquisto. Per maggiori informazioni sui termini della garanzia, consulti il Suo fornitore.

The lamp you have bought is guaranteed against aesthetic and operating faults for 24 months from the date of purchase. If you have a claim, return the appliance to your dealer with the cash register receipt or invoice showing the date of purchase. For further information on the terms of the guarantee, consult your dealer.

L'appareil d'éclairage que vous venez d'acheter est garanti pendant 24 mois à partir de la date d'achat contre tous défauts esthétiques et fonctionnels. En cas de réclamation nous vous prions de rendre à votre fournisseur l'appareil et le ticket de caisse ou la facture montrant la date d'achat. Pour plus de renseignements sur les conditions de la garantie, adressez-vous à votre fournisseur.

Für die von Ihnen erworbene Leuchte gewähren wir eine Garantie von 24 Monaten ab Kaufdatum hinsichtlich ästhetischer und funktioneller Defekte. Bitte geben Sie bei einer Reklamation die Leuchte Ihrem Händler mit dem Kassenschein oder der Rechnung, aus welchem/r das Datum des Kaufs hervorgeht, zurück. Weitere Informationen zu den Garantiebedingungen erhalten Sie bei Ihrem Händler.

NEMO

Nemo S.r.L.

Viale Brianza, 30

20823 Lentate sul Seveso (MB)

Tel. +39 0362 37 24 93

Fax +39 0362 34 03 71

info@nemolighting.com

www.nemolighting.com

contenuto imballo - box contents - packungsinhalt - contenu de l'emballage - contenido de la confección

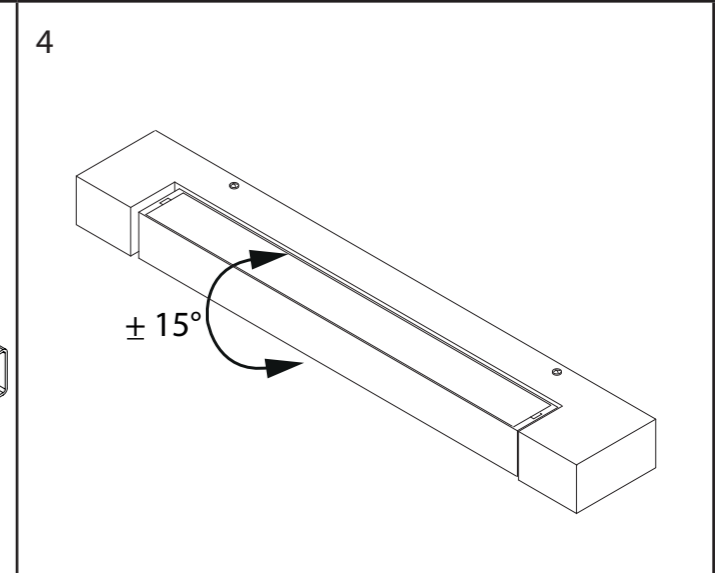
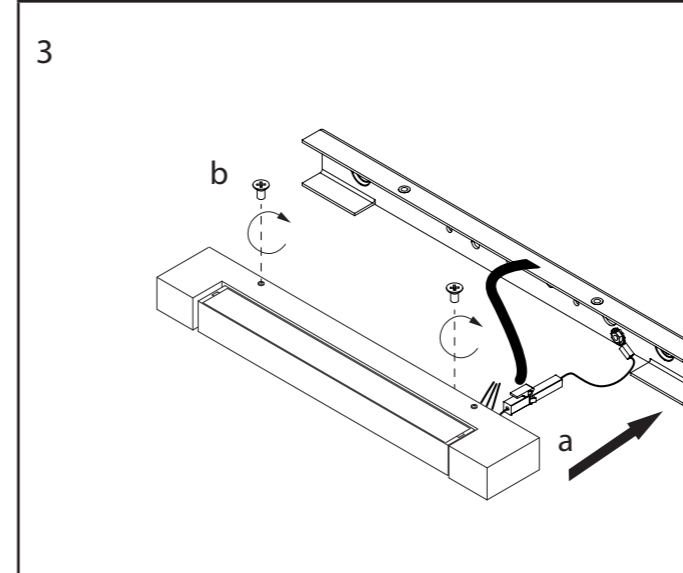
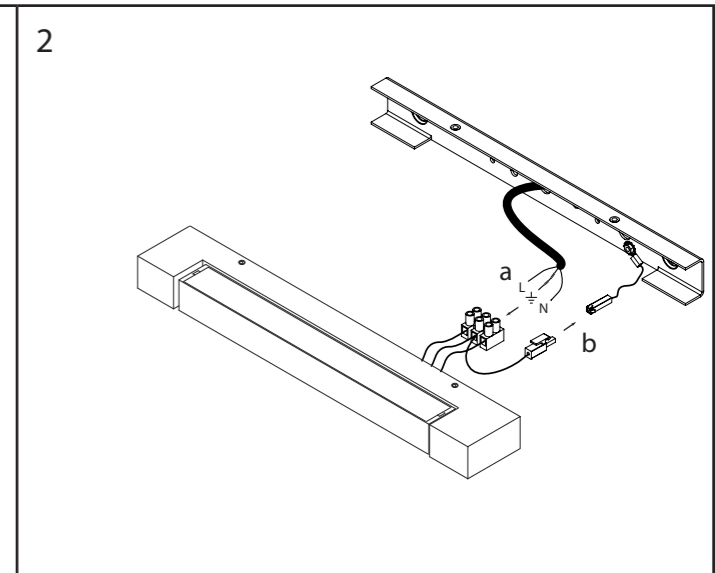
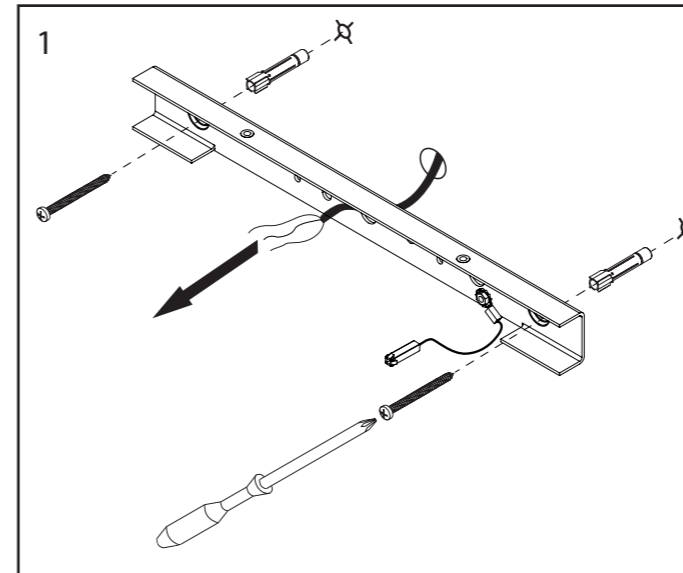
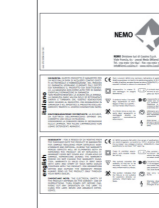
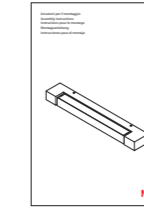
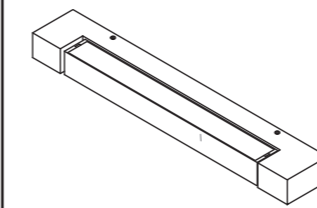

CONNESSIONE PER DIMMERAZIONE DALI DALI DIMMING CONNECTION

