

Marbulito Suspension Track 48V 1xLED GI

134220XX_134221XX_134224XX_134225XX

1 SHORTEN CABLE TO DESIRED LENGTH & CONNECT

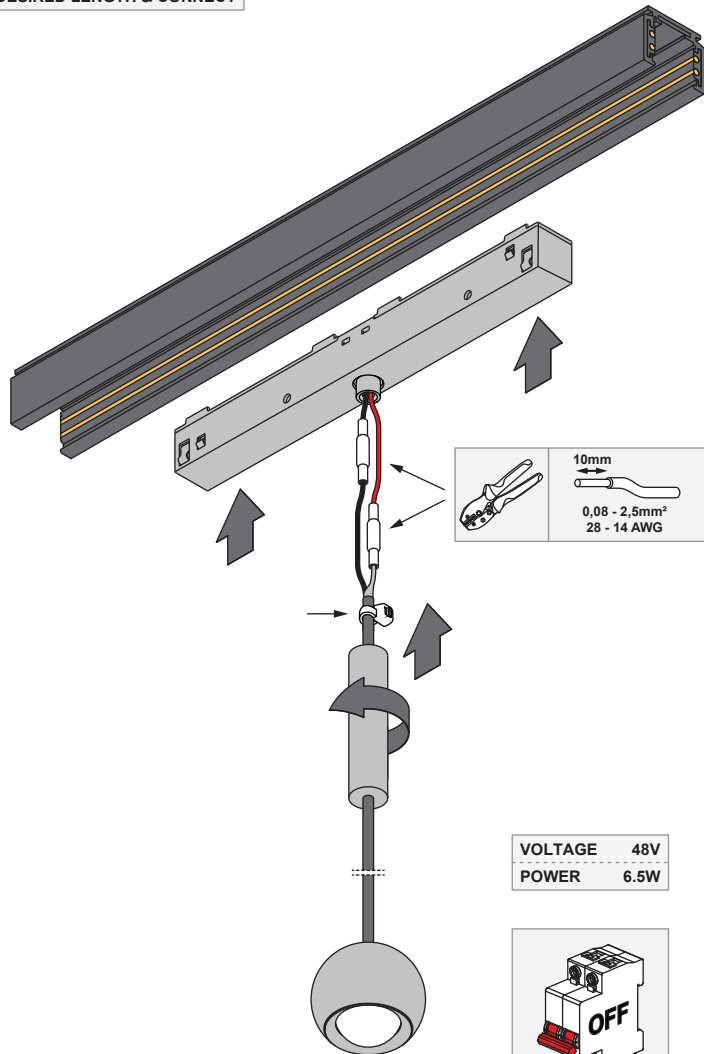
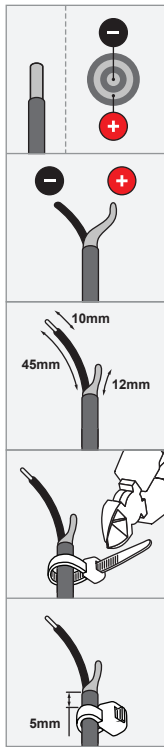

RESPECT POLARITY

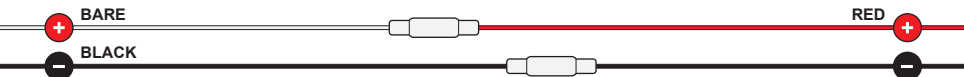

ADAPTER ORIENTATION ✓

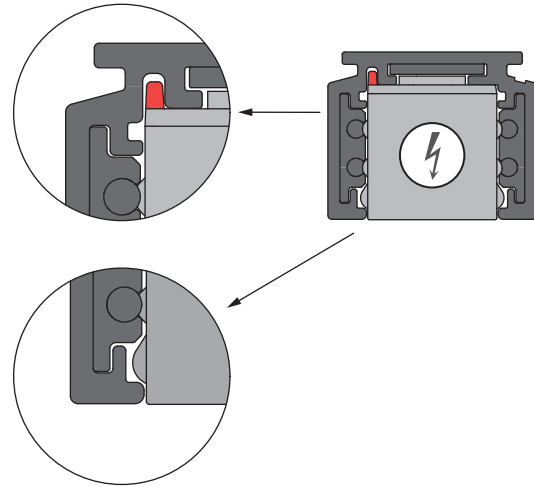

ADAPTER ORIENTATION ✗

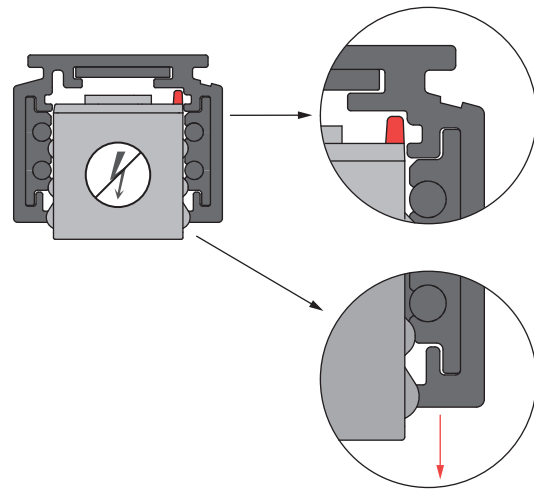

2

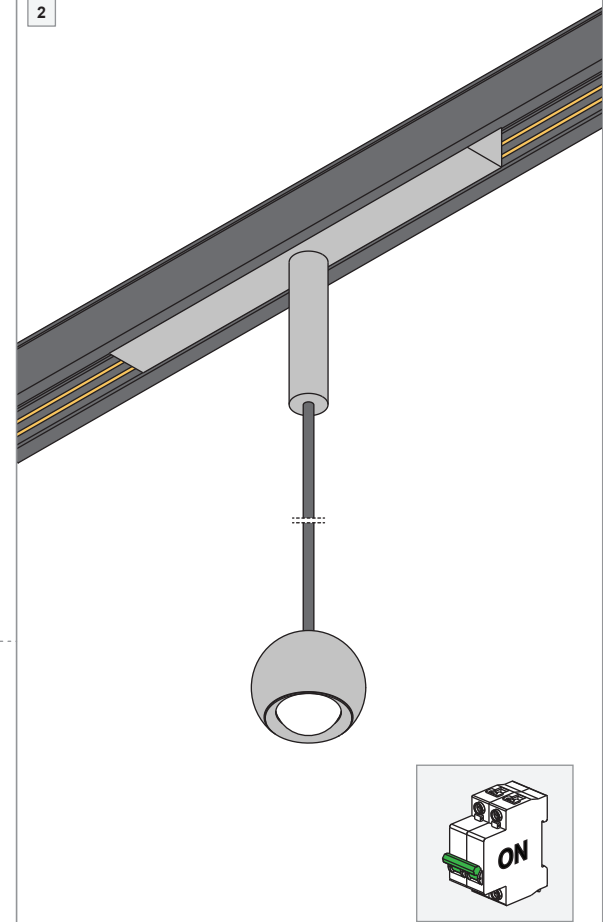

LIGHT SOURCE - DO NOT TOUCH LED

Touching the LED can result in permanent damage of the light source. The light source contained in this luminaire shall only be replaced by the manufacturer or his service agent or a similar qualified person.



PREVENTING ELECTROSTATIC DAMAGE

A discharge of static electricity may damage sensitive components. Therefore do not touch the LED nor the stripped parts of the wires with bare hands. Always be properly insulated by using ESD gloves.

DRIVERS & ACCESSORIES

For latest version of driver matrix and available accessories check www.supermodular.com or connect with your sales contact.

