

# AJ Floor

The fixture emits downward directed light. The angle of the shade can be adjusted to optimize light distribution. The shade is painted white on the inside to ensure a soft comfortable light.

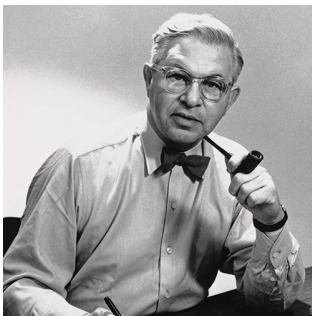

## Arne Jacobsen

Arne Jacobsen was born and raised in Copenhagen. In 1927, he graduated as an architect from the Royal Danish Academy of Fine Arts in Copenhagen. After graduating, he obtained his first job at the office of the City Architect of Copenhagen launching his own office only two years later.



## Carl Hansen & Son Showroom



## Sparekassen Vendsyssel

# Product info

**Finish**  
 White, Black, Aubergine, Dark Green, Dark Grey, Light Grey, Midnight Blue, Pale Petroleum, Rusty Red, Yellow Ochre, wet painted.

**Materials**  
 Shade: Spun steel. Base: Die cast zinc. Stem: Steel.

**Mounting**  
 Cable type: Plastic cord with plug. Cable length: 2.4m. Light control: In-line switch on cord.

**Class**  
 Ingress protection IP20. Electric shock protection II.

**Specification notes**  
 The white version is supplied with a white cable. The other versions are supplied with a black cable. The innovation of light sources is ongoing. Consequently we only inform about the max. wattages.

**Light source & energy class**  
 A+ - E | 1x20W E27

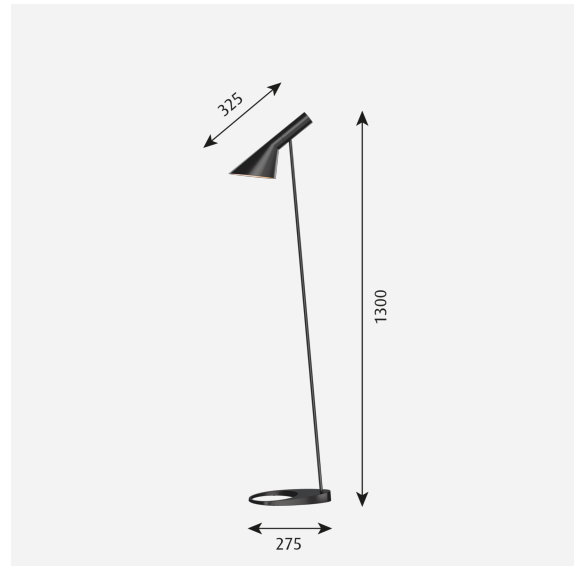

# Product family

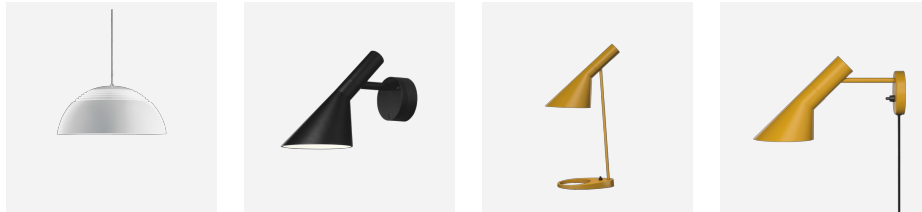

AJ Royal

AJ 50 Wall

AJ Table

AJ Wall

# Product variants

Light source	Colour	Class	Switch	Cable type
1x20W E27	Aubergine	II	W/ON/OFF SWITCH	BLK PL
	Black			WHT PL
	Dark green			
	Dark grey			
	Light grey			
	Midnight blue			
	Pale petroleum			
	Rusty red			
	Wht			
	Yellow ochre			

--	--	--	--	--

# Product description

Terse and iconic design

A semi-conical fixture head.

An arm fixed to a round mounting box holds the fixture head.

Fixture head pivots to direct light as needed.

Different colour variants.

Is a member of a product family for both outdoor and indoor

---

Portable fixture plugs into standard wall outlet.

---

## Light description

The fixture emits glare free, directed light.

Combined direct and indirect light ensures directed light with soft shadows

The shade is painted white on the inside to ensure a soft comfortable light distribution.

---

## Design

Arne Jacobsen

---

## Mounting

Fixture head and wall box: spun steel, 1.5mm (0.06") thick, wet painted.

Arm: extruded steel, 1.5mm (0.06") thick, wet painted.

Base: cast zinc plated steel, 1.5mm (0.06") thick.

Switch: on/off, phenolic, on cord.

Socket: Porcelain, medium base for A-19, frosted envelope lamps.

---

## Weight

Min: 3.372 kg Max: 3.372 kg

---

## Finish

Aubergine, Black, Dark green, Dark grey, Light grey, Midnight blue, Pale petroleum, Rusty red, Wht, Yellow ochre

# Light distribution diagrams

Cartesian

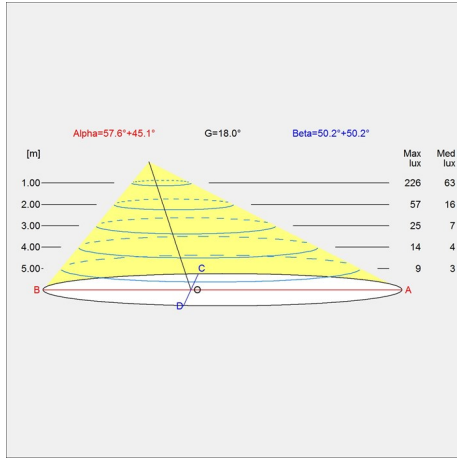

Isolux

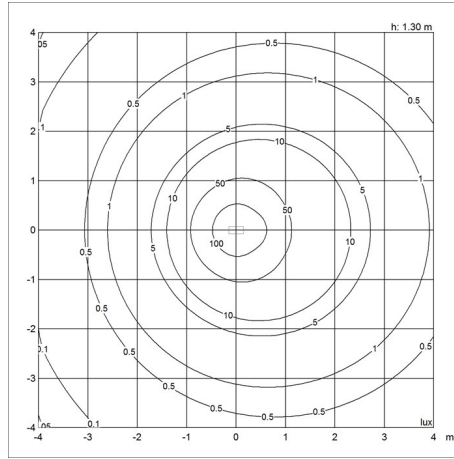

Polar

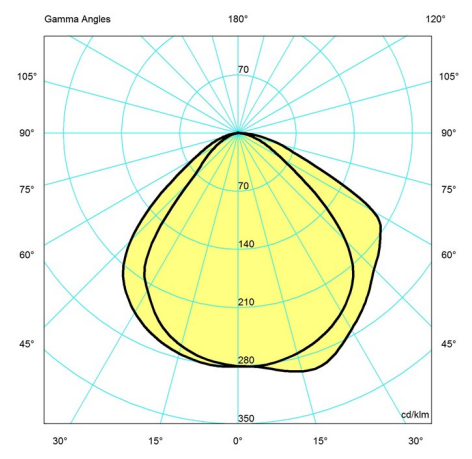

## Spare parts & accessories

Product	Variant number
FOOT SWITCH, ON/OFF, BLACK	571700000
FOOT SWITCH, ON/OFF, WHITE	571700013