

MONO II DOWN-UP LED

DEEL
PARTIE
TEIL
PART
PARTE
PARTE

A

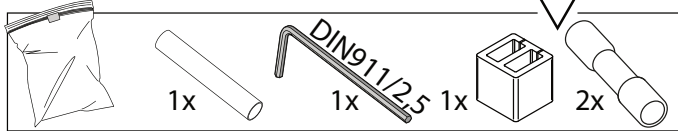
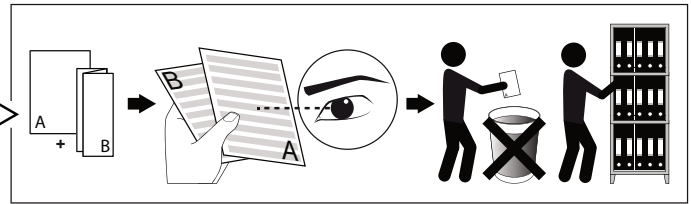

U	100-240V
P-down	7,1W
P-up	7,1W
P-Total	14,2W

IP54

Beschermd tegen stof - Spatwatervast
 Protégé contre les poussières - Protégé contre les projections d'eau
 Staubgeschützt - Geschützt gegen Spritzwasser
 Dust-protected - Protected against splashing water
 Protegido contra el polvo - Protegido contra salpicaduras de agua
 Protetto contro la polvere - Protetto contro gli schizzi d'acqua

Goederen zijn dubbel geïsoleerd - geen aarding nodig
 Les produits ont une isolation double et ne peuvent pas être mis à la terre
 Güter sind doppelt isoliert und müssen nicht geerdet werden
 Goods have double insulation and must not be grounded
 Los productos tienen un aislamiento doble y no se pueden conectar a tierra
 I prodotti possiedono un doppio isolamento e non devono essere collegati a terra

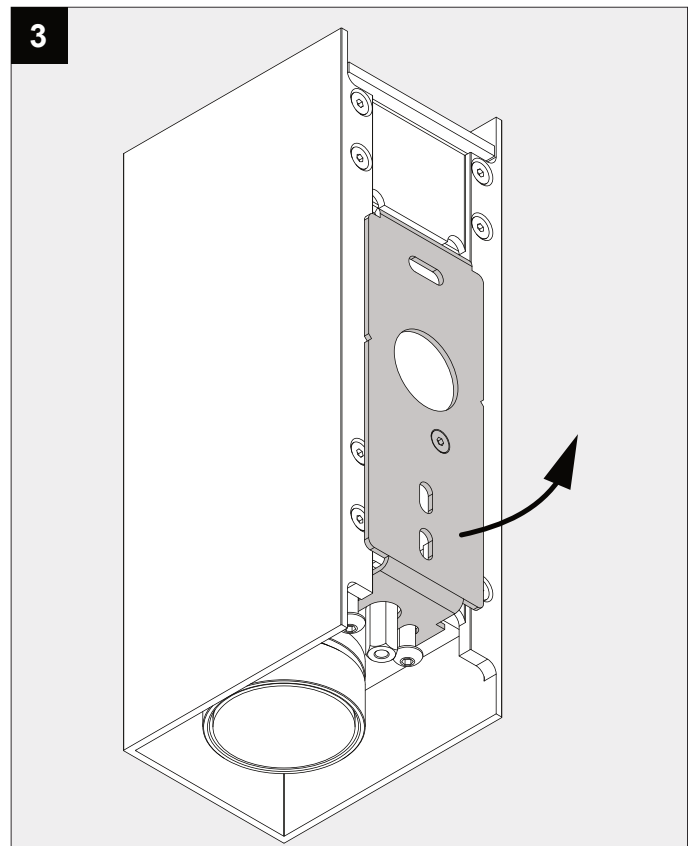
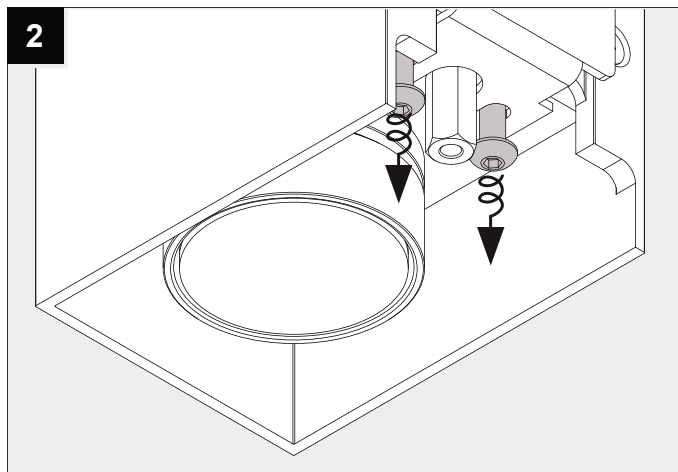
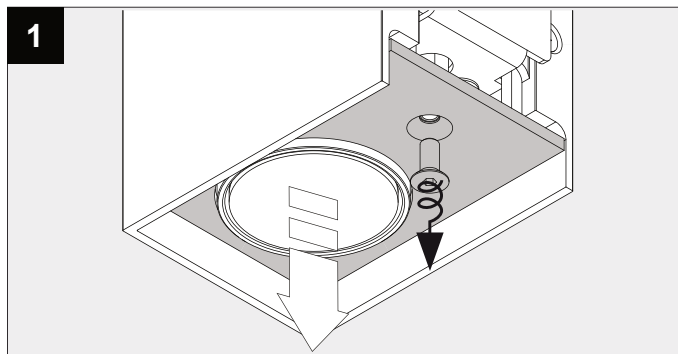

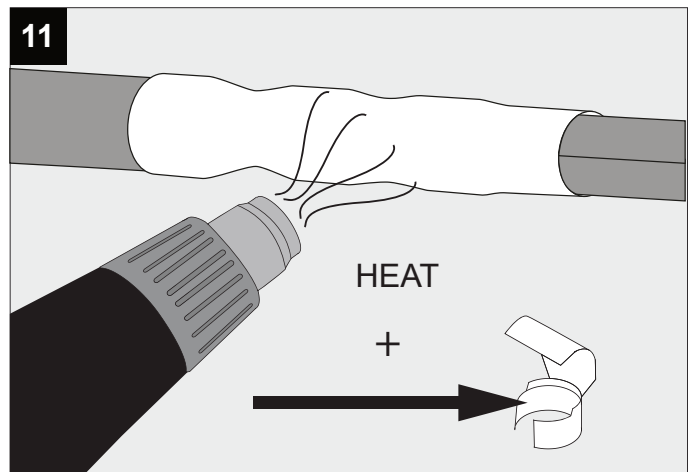
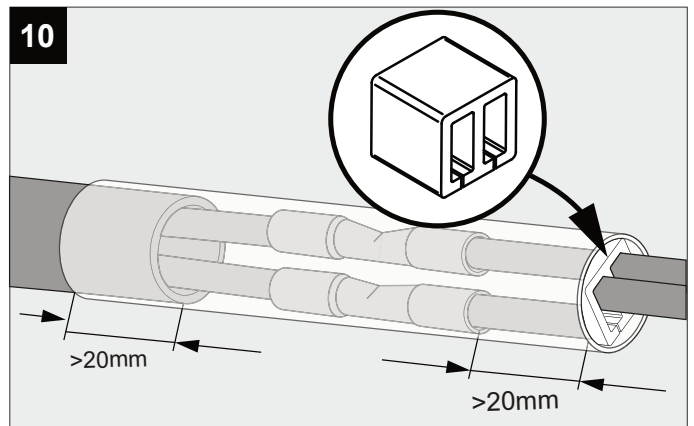
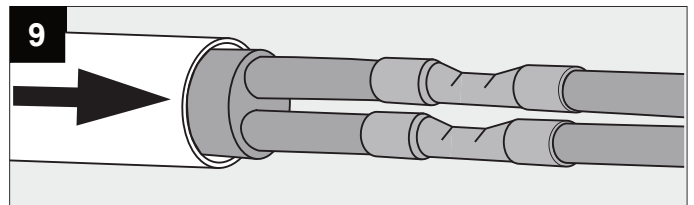
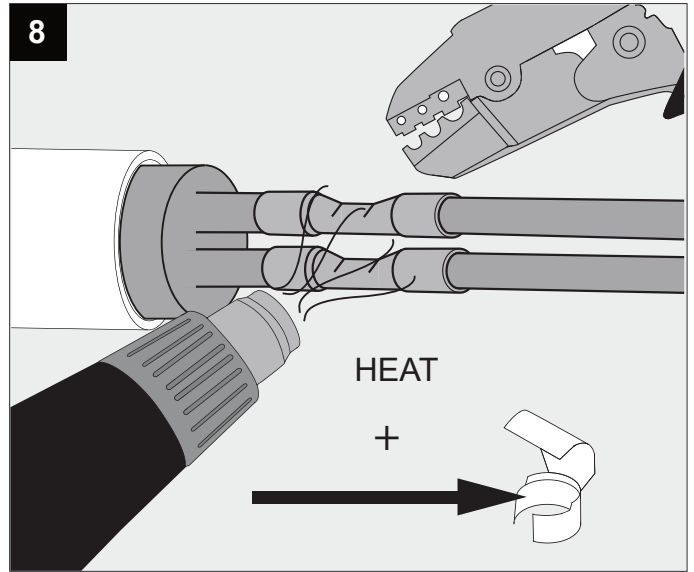
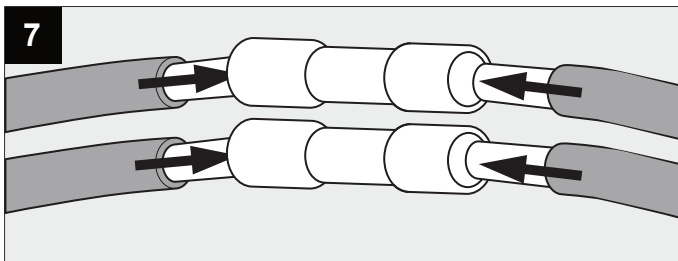
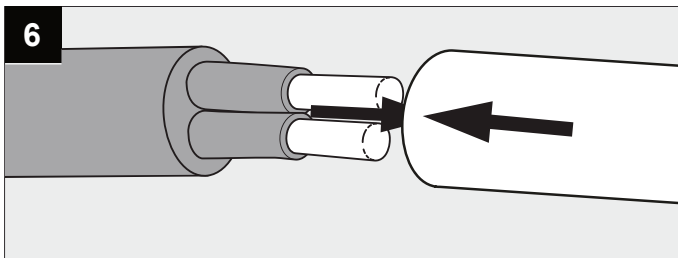
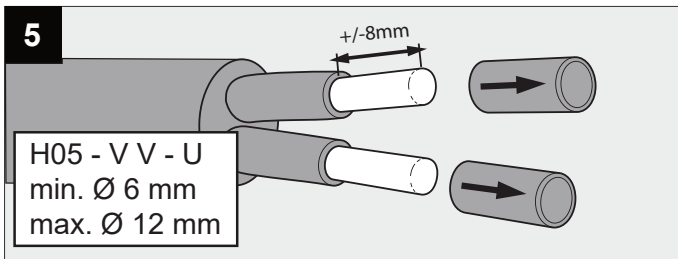
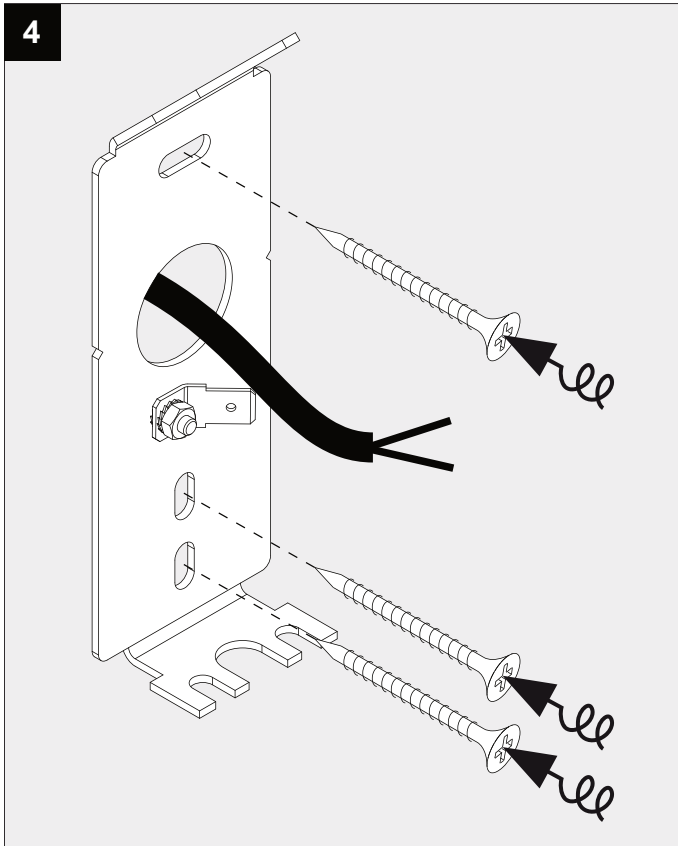

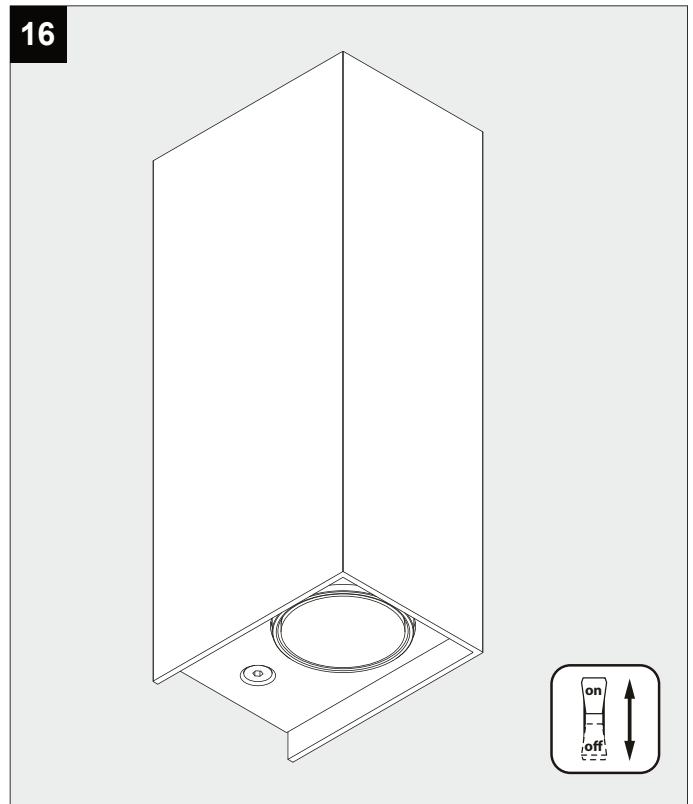
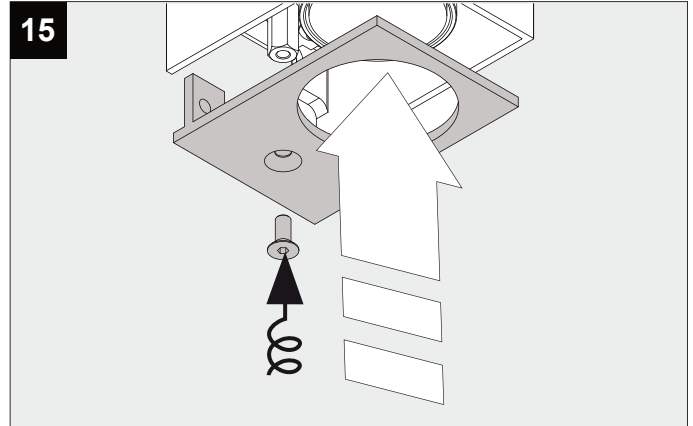
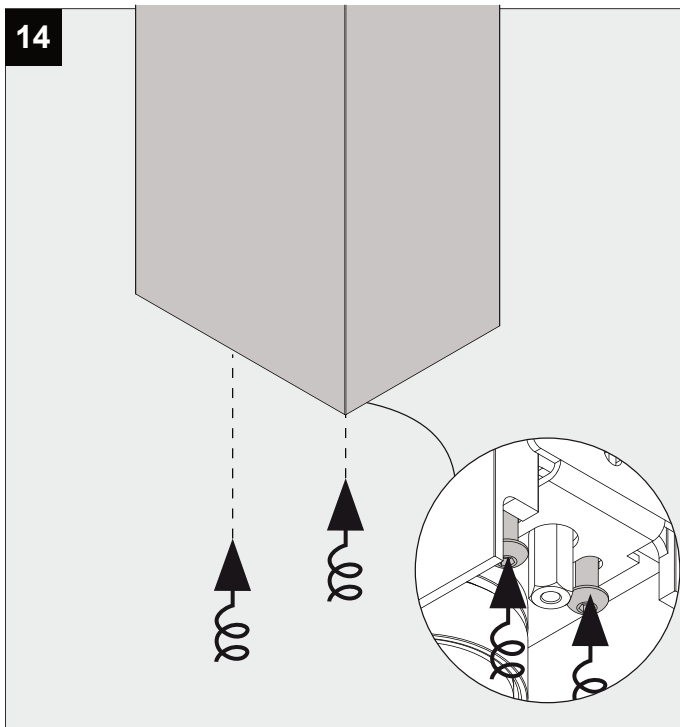
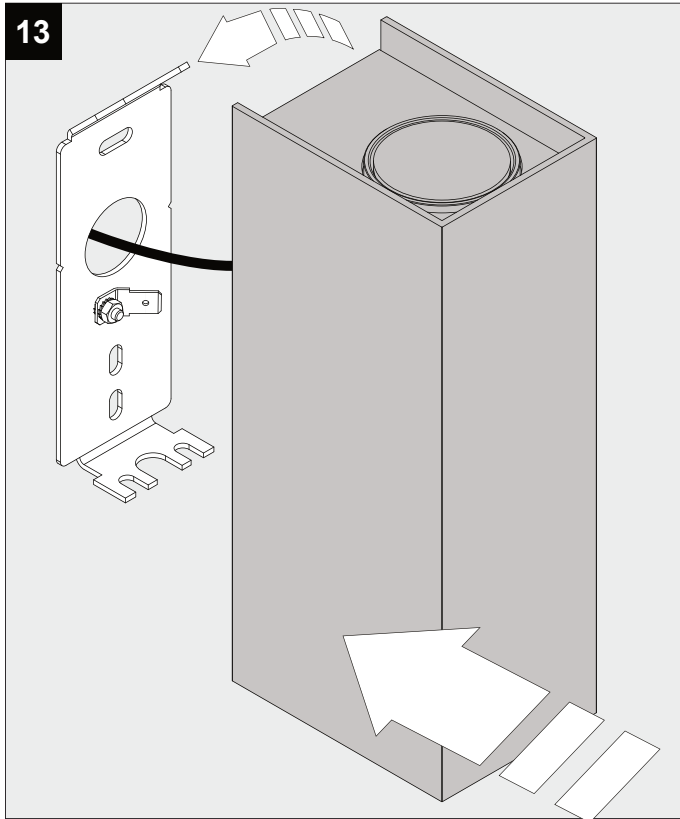
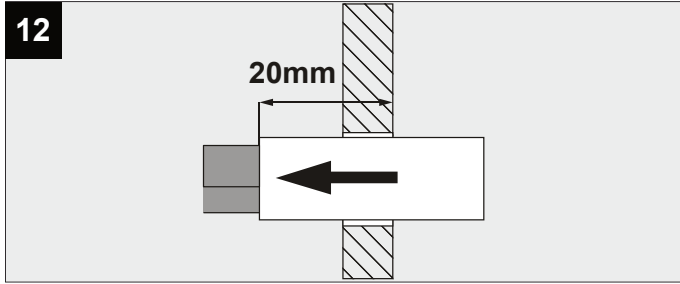

This product contains a light source of energy efficiency class E
 本产品包含能效等级为 E 的光源
 Этот артикул содержит источник света с энергоэффективностью класса E
 يحتوي هذا المنتج على مصدر ضوء ذو كفاءة الطاقة E

E Dit product bevat een verlichtingsbron van energie-efficiëntieklasse E
 Ce produit contient une source d'éclairage de classe d'efficacité énergétique E
 Dieses Produkt enthält eine Lichtquelle der Energieeffizienzklasse E
 Este producto contiene una fuente de iluminación de clase de eficiencia energética E
 Questo prodotto contiene una fonte di illuminazione in classe di efficienza energetica E

Replaceable (LED only) light source and control gear by a professional
 (仅针对LED)光源及其控制设备只能由专业人员更换
 (для СВЕТОДИОДНЫХ светильников) замена источника света и блока питания может быть произведена только квалифицированным специалистом

Verlichtingsbron (enkel LED) en voorschakelapparaat kan enkel vervangen worden door een professional
 La source d'éclairage (uniquement LED) et le ballast ne peut être remplacé que par un professionnel
 Die Lichtquelle (nur LED) und Vorschaltgerät kann nur von einem Fachmann ausgetauscht werden
 La fuente de iluminación (solo LED) solo puede ser reemplazada por un profesional
 La sorgente luminosa (LED) e l'alimentatore possono essere sostituiti solo da un professionista.



CAUTION! CLEAN AT LEAST QUATERLY WITH WATER AND NON-ABRASIVE CLOTH

De verlichtingsbron van dit verlichtingstoestel zal enkel door de fabrikant of door de fabrikant aangestelde installateur vervangen worden.

La source lumière de cet appareil ne sera remplacée que par l'entreprise ou par un agent reconnu.

Das enthaltene Leuchtmittel sollte nur durch entsprechendes Fachpersonal ersetzt werden.

The light source contained in this luminaire shall only be replaced by the manufacturer or his service agent.

La fuente de iluminación que tiene esta luminaria sólo puede remplazarse por el fabricante o por un instalador autorizado.

La sorgente luminosa incorporata in questo apparecchio può essere sostituita solo dal produt tore, da un suo centro assistenza oppure da una persona in possesso della necessaria abilitazione.

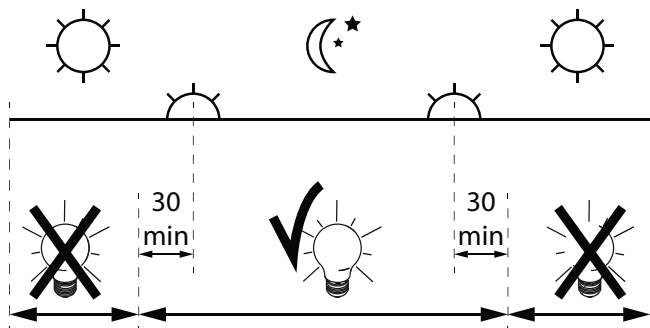

Dagelijkse ontstekingsperiode toegestaan
 Durée quotidienne d'allumage admissible
 Erlaubte tägliche einschaltdauer
 Allowed daily operation period
 Period giornaliero di accensione ammesso
 Periodo diario de encendido permitido