

XT-A DIRECT 150 1-10V

XA74-0

XA74-1

XA74-2

XA74-3

XA74-4

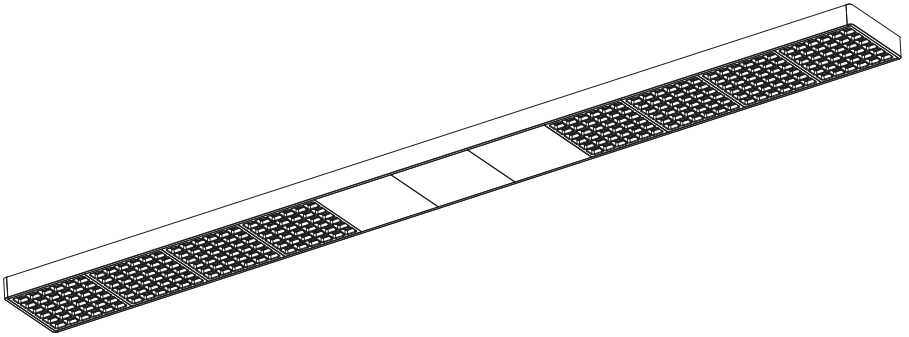

GRAU

XT-A DIRECT 150 1-10V

Lieferumfang / carton contents

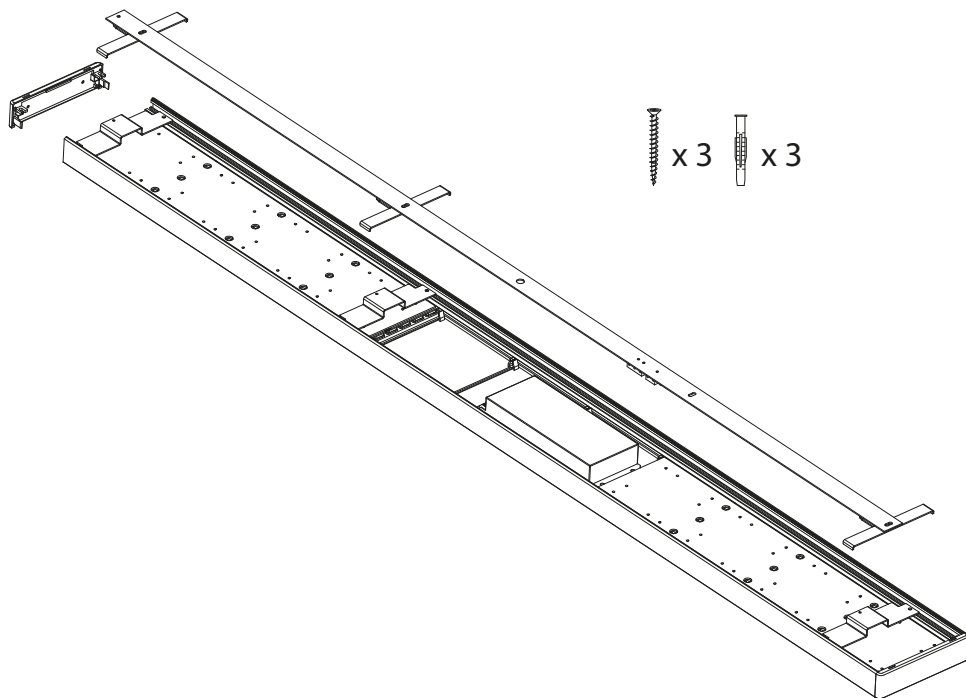

Montageanleitung • Assembly instructions • Notice de montage

01

Zum Lösen der Sicherungsschraube, die Endkappe gerade abziehen

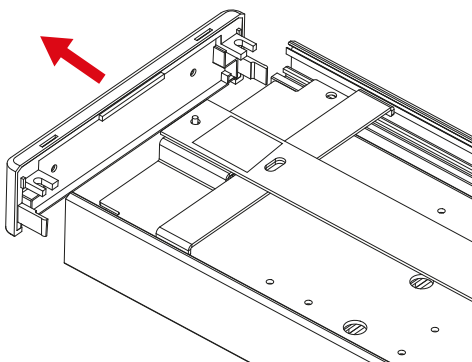

Zum Abziehen der Endkappe müssen keine Schrauben gelöst werden!!!!

02

Sicherungsschraube lösen - nicht entfernen!

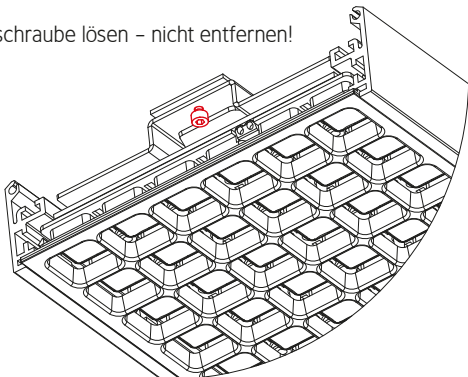

03

Das Deckenblech kann demontiert werden

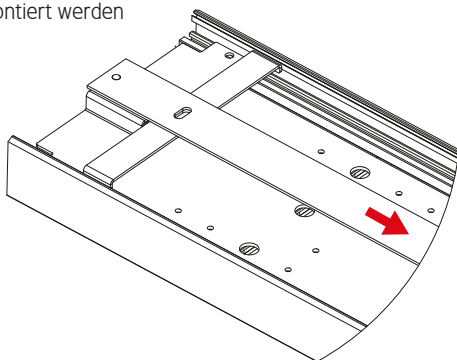

i

Anschluss der Leuchte • Connecting the lamp

01 ①

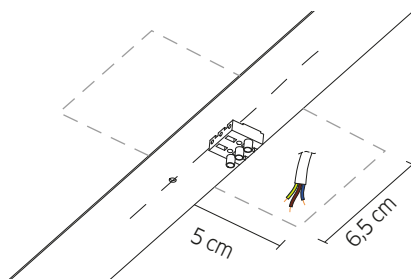

Mögliche Bereiche für Kabelaustritt Decke
(Litze kann nicht genau mittig über der Leuchte austreten)

Possible areas for cable exit in the ceiling.
(The wire can not exactly exit over the lamp)

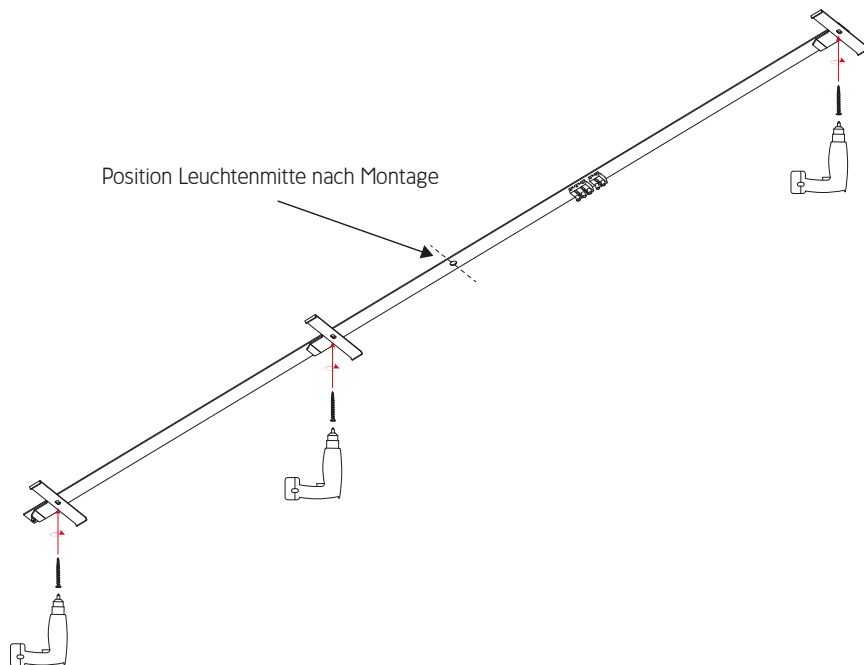

i ①

Anschluss der Leuchte • Connecting the lamp

02 Anschluss nicht dimmbar / Connecting not dimmable

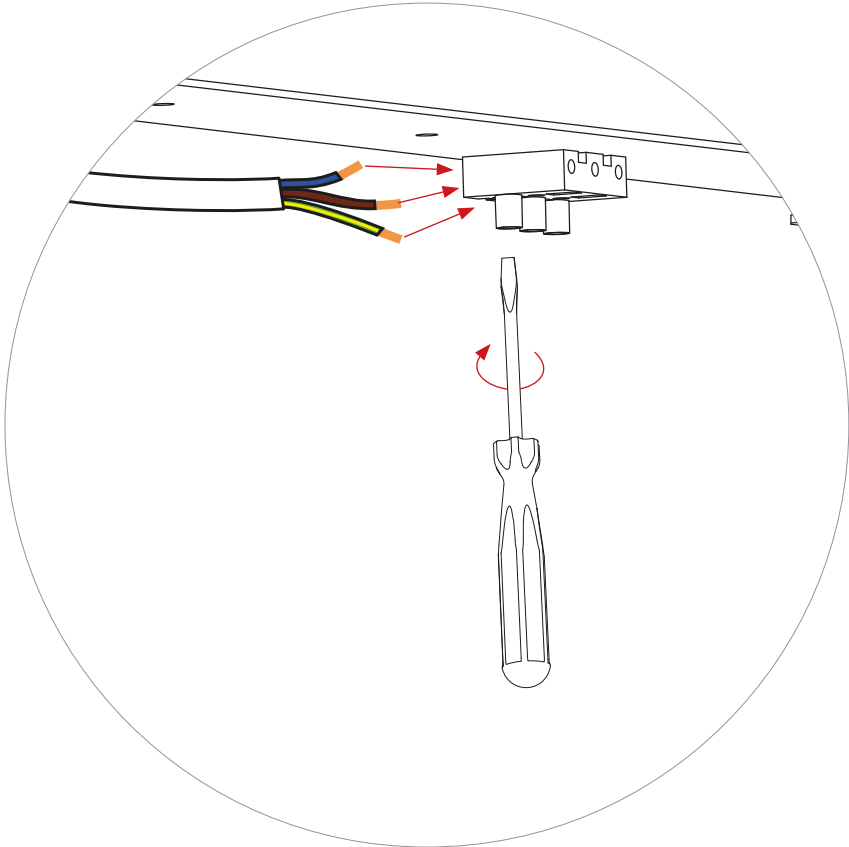

Anschluss der Leuchte • Connecting the lamp

03 Anschluss nicht dimmbar / Connecting not dimmable

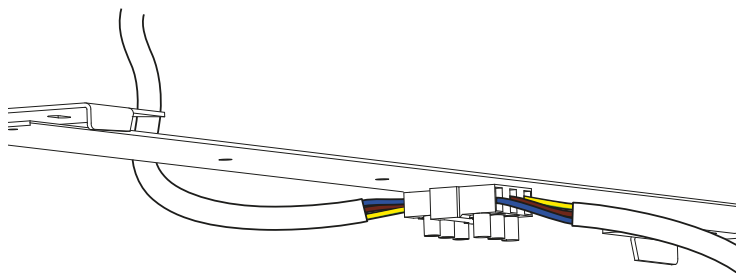
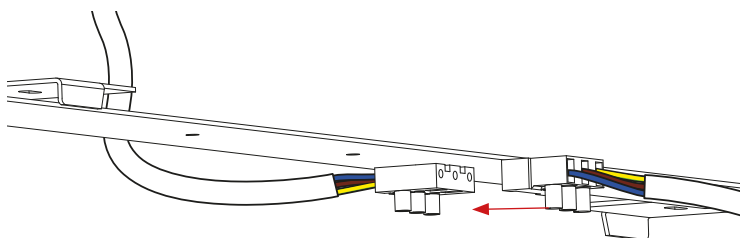

Anschluss der Leuchte • Connecting the lamp

04 Anschluss dimmbar / Connecting dimmable

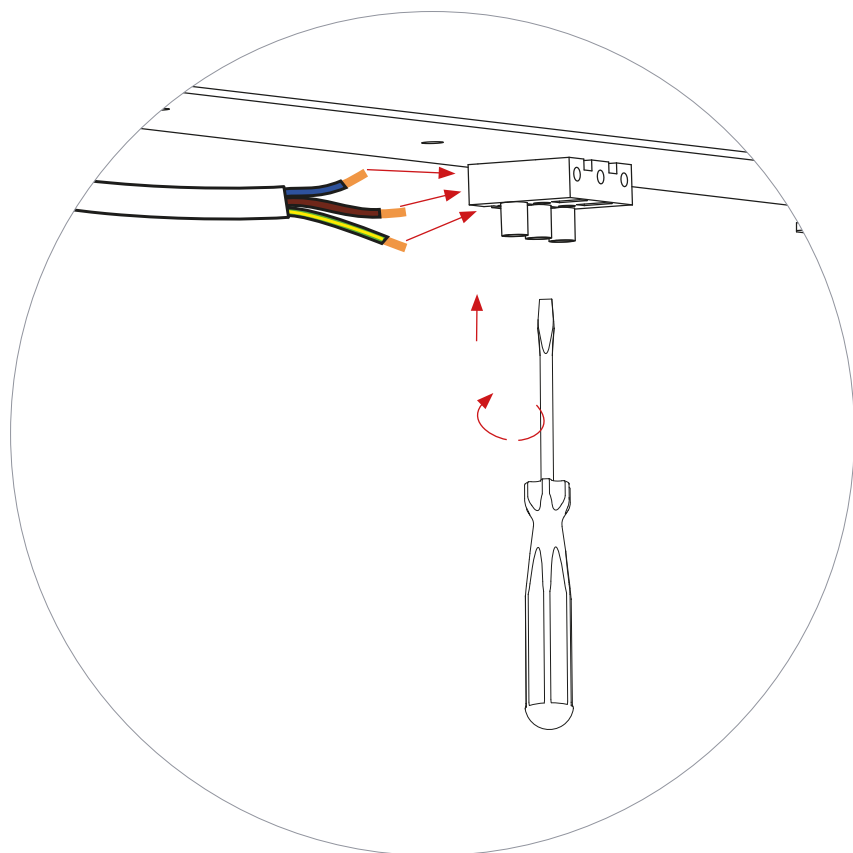

Anschluss der Leuchte • Connecting the lamp

05

Anschluss dimmbar / Connecting dimmable

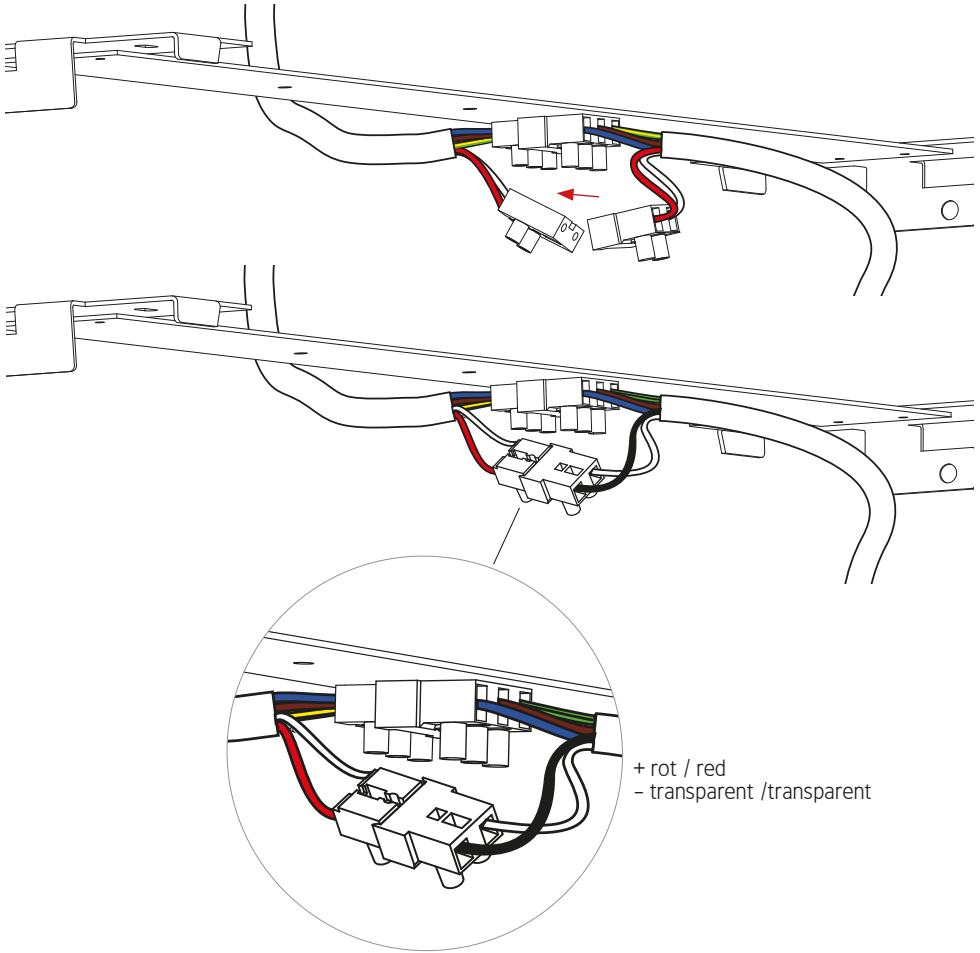

+ rot / red
- transparent / transparent

| | Kennfarbe / code colour | Funktion / function |
|------------------------------------------------------------------------------------|-----------------------------------|----------------------------------------------|
| T | transparent/rot / transparent/red | 1-10 Volt / control line 220-240V |
| L | schwarz / black | Phase / phase |
| N | blau / blue | Neutraleiter / neutral conductor |
|  | grün-gelb / green-yellow | Schutzleiter / protective earth conductor |



Anschluss der Leuchte • Connecting the lamp

06 5

Anschluss der Leuchte 5-adrig – Dimmung über elektronisches Potentiometer mit Druckauschalter und 1-10V Steuerausgang.

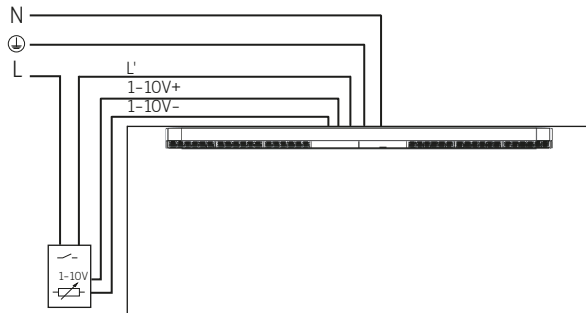

i 5

04 ① ② ③ ④

Leuchte an der Deckenschiene positionieren

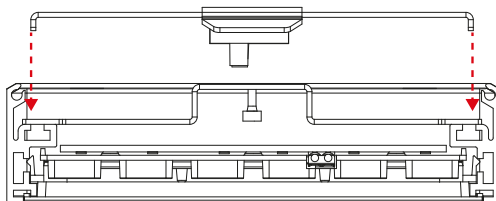
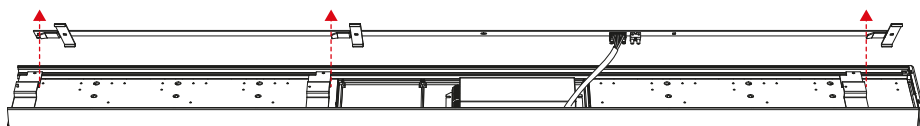

05

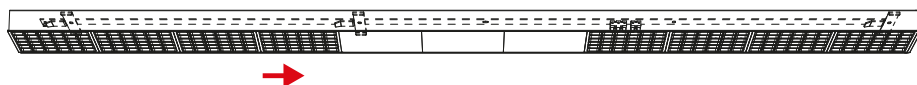

Leuchte auf Deckenschiene aufschieben.

Bitte vor dem Loslassen der Leuchte, den festen Sitz prüfen!

06

Sicherungsschraube wieder festziehen und testen,
dass sich die Leuchte nicht verschieben lässt!

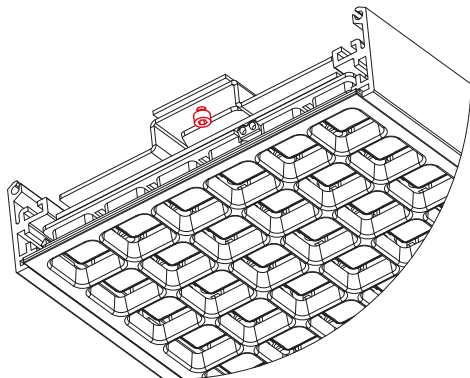

07

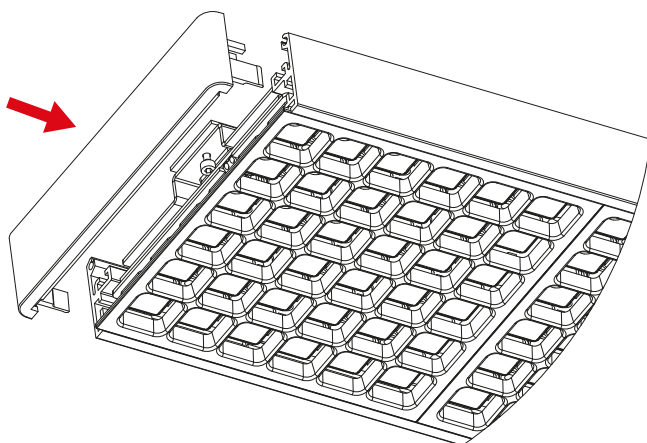





Endkappe bündig aufschieben.

i



DEUTSCH

- ① Die Auswahl der richtigen Befestigungsmittel obliegt dem Installateur.
- ② Beim Lösen Leuchte festhalten!
- ③ Abweichungen bei der Helligkeit und dem Weißton der verwendeten LEDs sind herstellungsbedingt und kein Grund für eine Beanstandung.
- ④ Bitte die Leuchte ausschließlich mit einem trockenen Tuch reinigen. Wir empfehlen Microfasertücher für empfindliche Oberflächen. Das Reinigen muss in abgekühltem Zustand erfolgen.
- ⑤ Achtung: Wenn auf der Installationsseite nur 3Adern (L, N, Erde) zur Verfügung stehen, läßt sich die Leuchte nicht dimmen. 1-10V+ und 1-10V- dürfen nicht angeschlossen werden!

| | |
|------------------------------------------------------------------------------------|--------------------------------------------------------------------------------------------------------------------------|
| XT-A DIRECT LED OSA 150 X 15, 1-10 V | |
|  | PRI 220-240V / 50-60 Hz / SEC 525mA / 56W LED |
|  | Schutzklasse 1 |
|  | Dieses Produkt enthält eine Lichtquelle der Energieeffizienzklasse C. Diese kann nur vom Hersteller ausgetauscht werden. |
|  | 73/23/EWG 89/336/EWG |





GARANTIE:

Sie haben ein hochwertiges Produkt erworben, welches mit Sorgfalt produziert und verpackt worden ist. Sollten Sie dennoch einmal Grund zur Beanstandung haben, wenden Sie sich bitte ausschließlich an Ihren Händler. Geben Sie bitte die auf der letzten Seite genannte Endkontrollnummer bei Ihrer Reklamation an. Ihre Reklamation wird bei uns im Hause umgehend bearbeitet. Bitte haben Sie Verständnis, dass eine Garantie unsererseits nur bei sachgemäßer Montage übernommen werden kann - wir empfehlen daher Fachbetriebe.



ENGLISH

- ① It is the installer's responsibility to choose the correct fixing method.
- ② Hold firmly when dismantling!
- ③ Differences in brightness and white tone of the LED's are conditional of manufacturing and are no reason for a complaint.
- ④ Please clean the lamp with a dry cloth. We recommend microfibre cloths for sensitive surfaces. Only clean the lamp after it has cooled down.
- ⑤ Caution: If there are only three leads (L,N, earth) available on the installation side, the lamp cannot be dimmed. 1-10V+ and 1-10V- must not be connected!

| | |
|------------------------------------------------------------------------------------|-------------------------------------------------------------------------------------------------------------------|
| XT-A DIRECT LED OSA 150 X 15, 1-10 V | |
|  | PRI 220-240V / 50-60 Hz / SEC 525mA / 56W LED |
|  | Protection class 1 |
|  | This product contains a light source of energy efficiency class C. The LEDs can be replaced by the producer only. |
|  | 73/23/EWG 89/336/EWG |





GUARANTEE:

You have purchased a high-quality product that was produced and packaged with the utmost care. Should you nevertheless have grounds for complaint, please contact your retailer quoting the final inspection number as stated on the last page of this document. We will deal with your complaint immediately. This warranty applies only to products that have been fitted appropriately – we therefore recommend fitting by qualified personnel.



FRANÇAIS

- ① Le choix des moyens de fixations appropriés incombe à l'installateur.
- ② Tenir le luminaire lors du desserrage!
- ③ Des différences de clarté et de couleur des blancs des LED sont liées à la production et ne donnent pas lieu à réclamation.
- ④ Veuillez nettoyer le luminaire uniquement avec un tissu sec. Nous conseillons des tissus micro pour surfaces sensibles. Le nettoyage doit s'effectuer lorsque le luminaire est froid.
- ⑤ Attention: Si du côté de l'installation une seule phase est disponible, il n'est pas possible de varier l'intensité lumineuse du luminaire. 1-10V + et 1-10V- ne doit pas être branché!

| | |
|------------------------------------------------------------------------------------|-------------------------------------------------------------------------------------------------------------------------------------------------------------------|
| XT-A DIRECT LED OSA 150 X 15, 1-10 V | |
|  | PRI 220-240V / 50-60 Hz / SEC 525mA / 56W LED |
|  | Classe de protection 1 |
|  | Ce produit contient une source lumineuse de classe d'efficacité énergétique C. Les LED intégrés dans le luminaire ne peuvent être remplacés que par le fabricant. |
|  | 73/23/EWG 89/336/EWG |





GARANTIE:

Vous venez de faire l'acquisition d'un produit de haute qualité, fabriqué et emballé avec le plus grand soin. Si, malgré le soin apporté, vous êtes amené à rencontrer un problème, merci de contacter exclusivement votre revendeur en indiquant le numéro de contrôle qui se trouve en dernière page. Notre société donnera suite sans tarder à votre réclamation. Vous comprenez aisément que nous ne pouvons assurer de garantie que dans le cas où le montage du matériel a été effectué correctement - par conséquent, nous vous recommandons de vous adresser à un spécialiste.



ITALIANO

- ① La scelta del giusto materiale per l'attacco spetta all'installatore.
- ② Tenere la lampada durante lo sganciamento!
- ③ Differenze in luminosità e nella tonalità bianca dei LED utilizzati sono dovute alla fabbricazione e non costituiscono motivo di reclamo.
- ④ Per favore pulire la lampada esclusivamente con un panno asciutto. Si consiglia di utilizzare tessuti in microfibra. Le lampade devono essere fredde durante la pulizia.
- ⑤ Attenzione: Se nell'impianto d'installazione solo una fase è disponibile, la lampada non è regolabile in luminosità. 1-10V+ e 1-10V- non deve essere connesso.

| | |
|------------------------------------------------------------------------------------|----------------------------------------------------------------------------------------------------------------------------------------------------|
| XT-A DIRECT LED OSA 150 X 15, 1-10 V | |
|  | PRI 220-240V / 50-60 Hz / SEC 525mA / 56W LED |
|  | Classe di sicurezza 1 |
|  | Questo prodotto contiene una sorgente luminosa di classe di efficienza energetica C. I LEDs possono essere cambiati esclusivamente dal produttore. |
|  | 73/23/EWG 89/336/EWG |

GARANZIA:

Avete deciso di acquistare un prodotto d'alto valore, prodotto ed imballato con accuratezza. Se ci fossero ragioni per un reclamo, vi preghiamo di rivolgervi esclusivamente al vostro rivenditore di fiducia. Per favore indicate per chiarezza il numero di controllo stampato sull'ultima pagina. Il vostro reclamo sarà elaborato presso di noi. Considerate che da parte nostra possiamo assumere la garanzia del prodotto soltanto nel caso in cui il montaggio avvenga a regola d'arte: consigliamo dunque di rivolgersi ad aziende d'installazione specializzate.

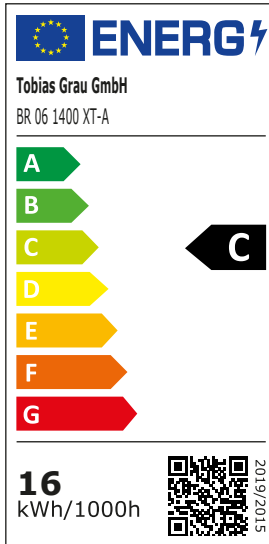

| | |
|----------------------------|----------------------------------------------------|
| Endkontrollnummer | 2 Jahre Garantie 5 Jahre Garantie auf die LED |
| Final inspection number | 2 years guarantee 5 years guarantee of LED |
| Numéro de contrôle final | 2 ans de garantie 5 ans de garantie sur les LED |
| Numero di controllo finale | 2 anni di garanzia 5 anni di garanzia per i LED |