

# XT-A CEILING LED OSA DL & IL

150X15 1-10V

XA50-0

XA50-1

XA50-3

XA56-0

XA56-1

XA56-3

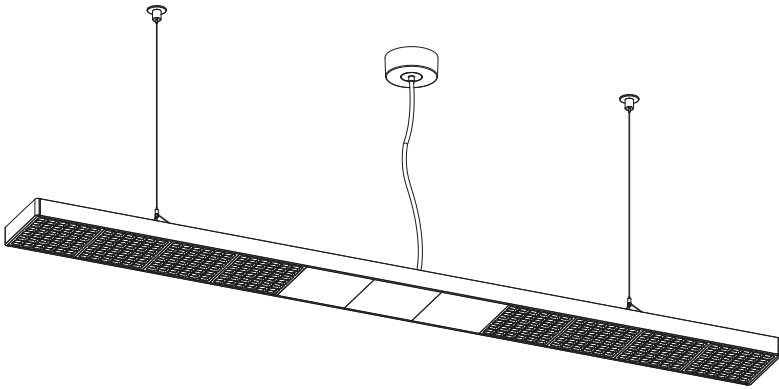

**tobias grau**

# Abstände und Längen • Lengths and distances

01

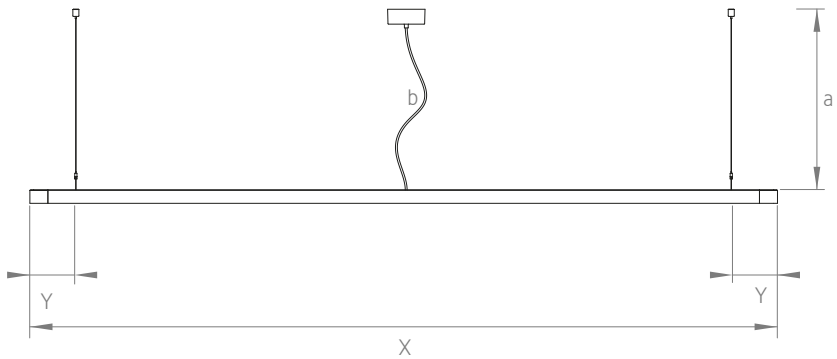

XT-A CEILING LED OSA – XA50-0/ XA50-1/ XA50-3

X	Y	a	b
1530 mm	ca. 200-250 mm	max. 1000 mm	a+50mm

Kabellänge (sichtbarer Bereich) • cable length (visible section)  $b = a + \text{ca. } 50\text{mm}$



# Montageanleitung • Assembly instructions

01

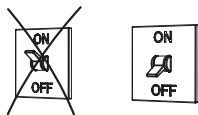

02

1

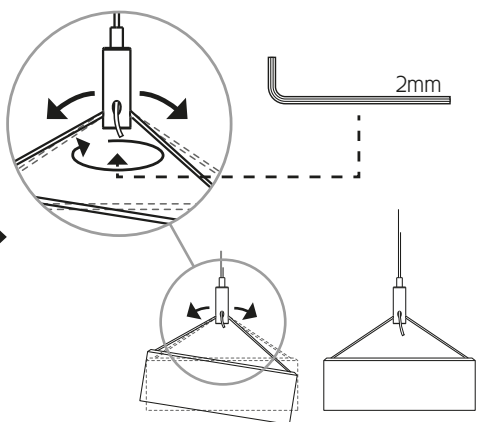
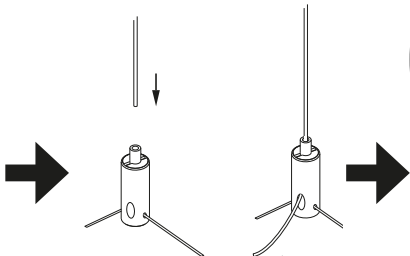
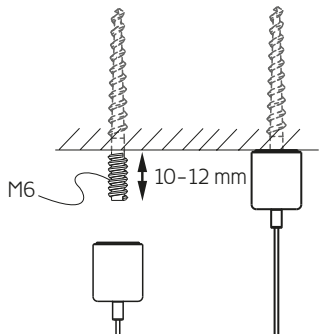
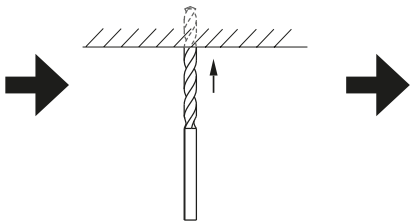
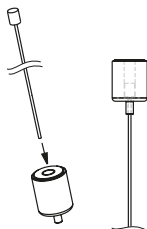

03

2

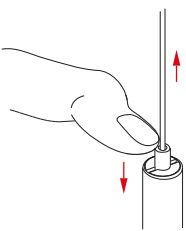

## Montageanleitung • Assembly instructions

04 ①

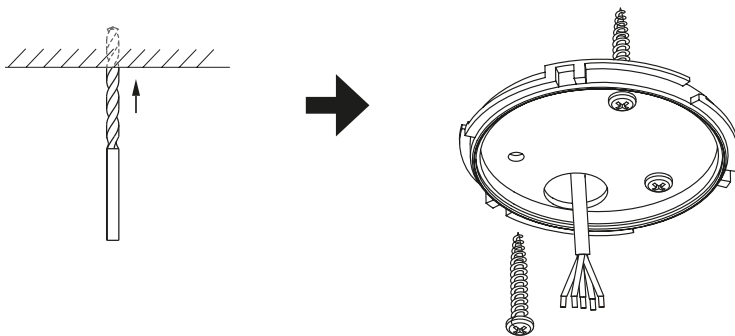

## Anschluss der Leuchte • Connecting the lamp

05 ③

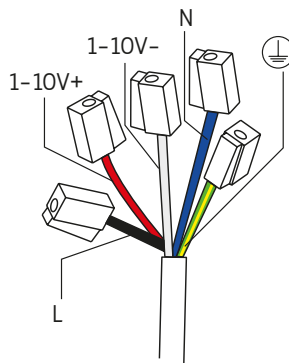

	Kennfarbe / code colour	Funktion / function
1-10V - / +	transparent/rot / transparent/red	Steuerleitung / control line <del>220-240V</del>
L	braun / brown	Phase / phase
N	blau / blue	Neutralleiter / neutral conductor
Ⓧ	grün-gelb / green-yellow	Schutzleiter / protective earth conductor

i ① ③

## Anschluss der Leuchte • Connecting the lamp

05 ③

Anschluss der Leuchte 5-adrig – Dimmung über elektronisches Potentiometer mit Druckausschalter und 1-10V Steuerausgang

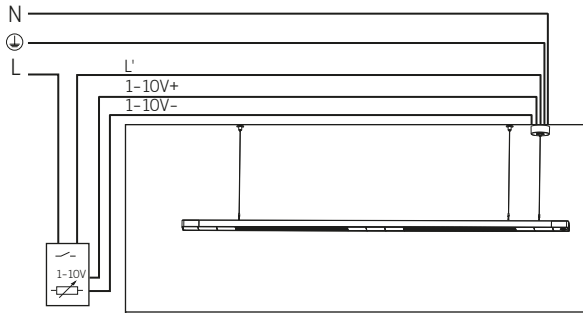

Anschluss der Leuchte 3-adrig – nicht dimmbar

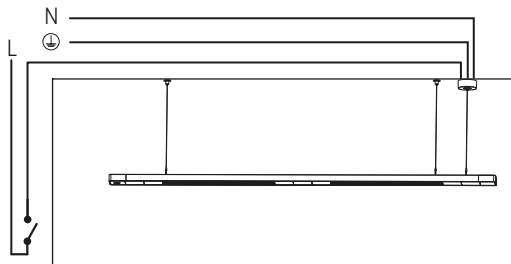

i ③

06

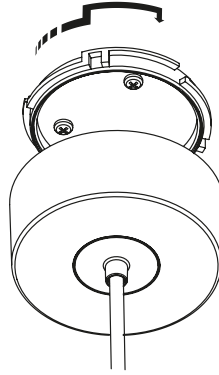
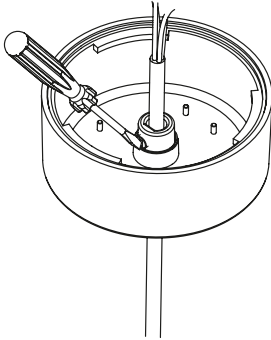









## DEUTSCH

- ① Die Auswahl der richtigen Befestigungsmittel obliegt dem Installateur.
- ② Beim Lösen Leuchte festhalten!
- ③ Achtung: Wenn auf der Installationsseite nur 3Adern (L, N, Erde) zur Verfügung stehen, lässt sich die Leuchte nicht dimmen. 1-10V+ und 1-10V- dürfen nicht angeschlossen werden!
- ④ Abweichungen bei der Helligkeit und dem Weißton der verwendeten LEDs sind herstellungsbedingt und kein Grund für eine Beanstandung.
- ⑤ Bitte die Leuchte ausschließlich mit einem trockenen Tuch reinigen. Wir empfehlen Microfasertücher für empfindliche Oberflächen. Das Reinigen muss in abgekühltem Zustand erfolgen.

<b>XT-A DIRECT/INDIRECT LED OSA</b>	
	Schutzklasse 1
	Diese Leuchte enthält eingebaute LEDs. Die LEDs in dieser Leuchte können nur vom Hersteller ausgetauscht werden. A-A++
	PRI 220-240V / 50-60 Hz / SEC 48V max. 1,05A / 75W LED (DL) / 90W LED (IL)
EN 12464	Die Leuchte ist nach EN 12464 bildschirmarbeitsplatztauglich
	Montage auf normal entflammaren Flächen zulässig.
	73/23/EWG   89/336/EWG

### GARANTIE:

Sie haben ein hochwertiges Produkt erworben, welches mit Sorgfalt produziert und verpackt worden ist. Sollten Sie dennoch einmal Grund zur Beanstandung haben, wenden Sie sich bitte ausschließlich an Ihren Händler. Geben Sie bitte die auf der letzten Seite genannte Endkontrollnummer bei Ihrer Reklamation an. Ihre Reklamation wird bei uns im Hause umgehend bearbeitet. Bitte haben Sie Verständnis, dass eine Garantie unsererseits nur bei sachgemäßer Montage übernommen werden kann - wir empfehlen daher Fachbetriebe.





## ENGLISH

- ① It is the installer's responsibility to choose the correct fixing method.
- ② Hold firmly when dismantling!
- ③ Caution: If there are only three leads (L,N, earth) available on the installation side, the lamp cannot be dimmed. 1-10V+ and 1-10V- must not be connected!
- ④ Differences in brightness and white tone of the LED's are conditional of manufacturing and are no reason for a complaint.
- ⑤ Please clean the lamp with a dry cloth. We recommend microfibre cloths for sensitive surfaces. Only clean the lamp after it has cooled down.

<b>XT-A DIRECT/INDIRECT LED OSA</b>	
	Protection class 1
	This luminaire contains built-in LEDs. The LEDs can be replaced by the producer only. A-A++
	PRI 220-240V / 50-60 Hz / SEC 48V max. 1,05A / 75W LED (DL) / 90W LED (IL)
EN 12464	Based on EN 12464 the lamp is suitable for workstations.
	Mounting on normally flammable surfaces permissible.
	73/23/EWG   89/336/EWG





### GUARANTEE:

You have purchased a high-quality product that was produced and packaged with the utmost care. Should you nevertheless have grounds for complaint, please contact your retailer quoting the final inspection number as stated on the last page of this document. We will deal with your complaint immediately. This warranty applies only to products that have been fitted appropriately – we therefore recommend fitting by qualified personnel.



## FRANÇAIS

- ① Le choix des moyens de fixations appropriés incombe à l'installateur.
- ② Tenir le luminaire lors du desserrage!
- ③ Attention: Si du côté de l'installation une seule phase est disponible, il n'est pas possible de varier l'intensité lumineuse du luminaire. 1-10V + et 1-10V- ne doit pas être branché!
- ④ Des différences de clarté et de couleur des blancs des LED sont liées à la production et ne donnent pas lieu à réclamation.
- ⑤ Veuillez nettoyer le luminaire uniquement avec un tissu sec. Nous conseillons des tissus micro pour surfaces sensibles. Le nettoyage doit s'effectuer lorsque le luminaire est froid.

XT-A DIRECT/INDIRECT LED OSA	
	Classe de protection 1
	Ce luminaire est équipé de LEDs intégrés. Les LED intégrés dans le luminaire ne peuvent être remplacés que par le fabricant. A-A++
	PRI 220-240V / 50-60 Hz / SEC 48V max. 1,05A / 75W LED (DL) / 90W LED (IL)
EN 12464	Le luminaire est conforme à la norme EN 12464 pour le travail sur écran d'ordinateur.
	Montage autorisé sur surface normalement inflammables.
	73/23/EWG   89/336/EWG





### GARANTIE:

Vous venez de faire l'acquisition d'un produit de haute qualité, fabriqué et emballé avec le plus grand soin. Si, malgré le soin apporté, vous êtes amené à rencontrer un problème, merci de contacter exclusivement votre revendeur en indiquant le numéro de contrôle qui se trouve en dernière page. Notre société donnera suite sans tarder à votre réclamation. Vous comprenez aisément que nous ne pouvons assurer de garantie que dans le cas où le montage du matériel a été effectué correctement – par conséquent, nous vous recommandons de vous adresser à un spécialiste.



## ITALIANO

- 1 La scelta del giusto materiale per l'attacco spetta all'installatore.
- 2 Tenere la lampada durante lo sganciamento!
- 3 Attenzione: Se nell'impianto d'installazione solo una fase è disponibile, la lampada non è regolabile in luminosità. 1-10V + e 1-10V- non deve essere connesso.
- 4 Differenze in luminosità e nella tonalità bianca dei LED utilizzati sono dovute alla fabbricazione e non costituiscono motivo di reclamo.
- 5 Per favore pulire la lampada esclusivamente con un panno asciutto. Si consiglia di utilizzare tessuti in microfibra. Le lampade devono essere fredde durante la pulizia.

XT-A DIRECT/INDIRECT LED OSA	
	Classe di sicurezza 1
	Questa lampada ha LEDs integrati. I LEDs possono essere cambiati esclusivamente dal produttore. A-A++
	PRI 220-240V / 50-60 Hz / SEC 48V max. 1,05A / 75W LED (DL) / 90W LED (IL)
EN 12464	Come da norma EN 12464 la lampada è adatta all'illuminazione di posti di lavoro con videotermini.
	Montaggio autorizzato su superfici normalmente infiammabili.
	73/23/EWG   89/336/EWG

### GARANZIA:

Avete deciso di acquistare un prodotto d'alto valore, prodotto ed imballato con accuratezza. Se ci fossero ragioni per un reclamo, vi preghiamo di rivolgervi esclusivamente al vostro rivenditore di fiducia. Per favore indicate per chiarezza il numero di controllo stampato sull'ultima pagina. Il vostro reclamo sarà elaborato presso di noi. Considerate che da parte nostra possiamo assumere la garanzia del prodotto soltanto nel caso in cui il montaggio avvenga a regola d'arte: consigliamo dunque di rivolgersi ad aziende d'installazione specializzate.

Endkontrollnummer	2 Jahre Garantie 5 Jahre Garantie auf die LED
Final inspection number	2 years guarantee 5 years guarantee of LED
Numéro de contrôle final	2 ans de garantie 5 ans de garantie sur les LED
Numero di controllo finale	2 anni di garanzia 5 anni di garanzia per i LED

