

**HEDRA ON**

DEEL  
PARTIE  
TEIL  
PART  
PARTE  
PARTE **A**

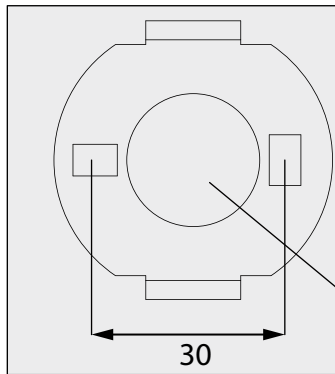
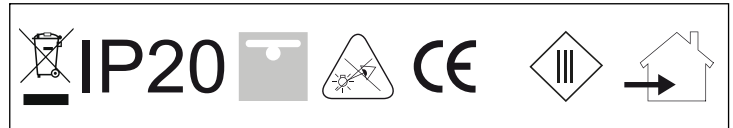
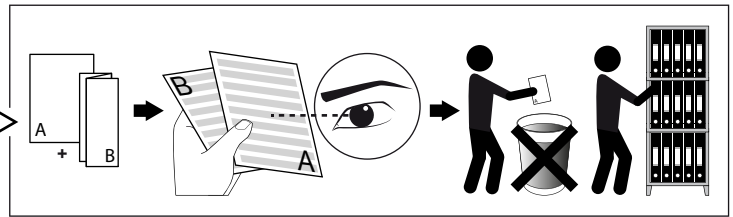

**ACCESSORIES**

Mounting kit flush spy 414 90 01

**OPTIONS**

Coversert R 100 204 00 100  
Coversert R 90 204 00 90  
Vizir honeycomb 40 473 03 01  
Vizir softening lens 40 473 03 04

**REQUIRED**

Vizir tube 473 01 00

I <sub>o</sub>	<b>500mA</b>
P <sub>o</sub>	<b>6W</b>
U <sub>f</sub> Typical	<b>11,9V-DC</b>

**IP20**

Beschermd tegen vaste voorwerpen die groter zijn dan 12 mm  
Protégé contre les objets solides de plus de 12 mm  
Geschützt gegen Festkörper größer als 12 mm  
Protected against solid objects greater than 12 mm  
Protegido contra objetos sólidos superiores a 12 mm  
Protetto contro oggetti solidi più grandi di 12 mm

Enkel geschikt voor toestellen op zeer lage spanning (minder dan 50 V-AC / 120 V-DC)  
Convient uniquement pour les produits à très basse tension (moins de 50 V-AC / 120 V-DC)  
Geeignet für Güter mit sehr niedriger Spannung (unter 50 V-AC / 120 V-DC)  
Only suited for goods at very low voltage (below 50 V-AC / 120 V-DC)  
Se recomienda únicamente para aquellos productos de tensión muy baja (menos de 50 V-AC / 120 V-DC)  
Vale unicamente per i prodotti a tensione molto bassa (inferiore a 50 V-AC / 120 V-DC)

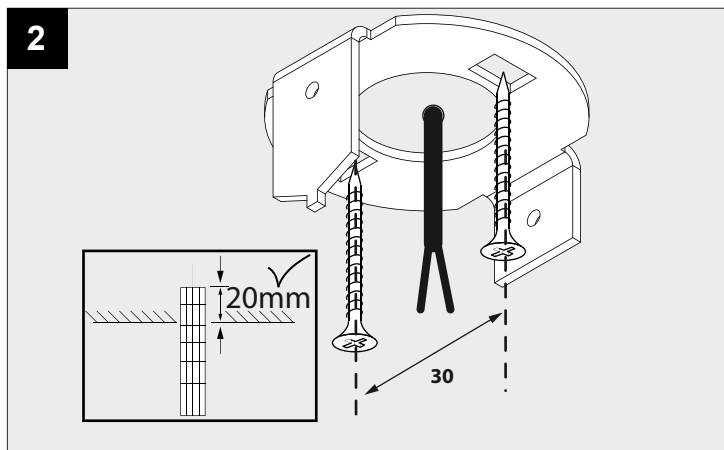
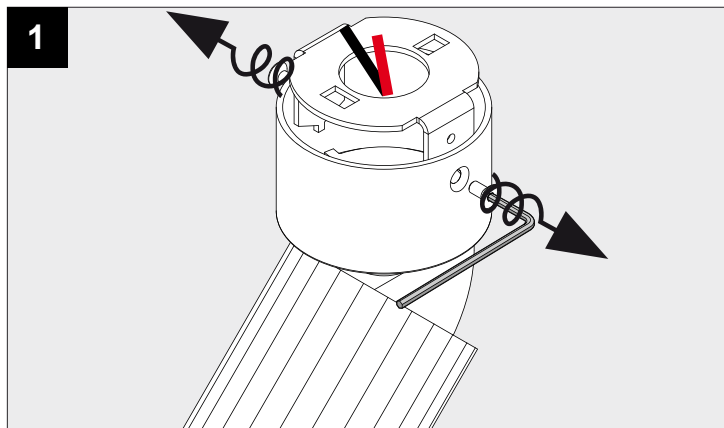

Het toestel dient op een plaats te worden gemonteerd van waaruit langdurig staren in de lichtbron, vanop een afstand van 0,537m, vermeden wordt.  
Le luminaire doit être positionné afin d'éviter tous contacts prolongés visuels à moins de 0,537m.  
The luminaire should be positioned so that prolonged staring into the luminaire at a distance closer than 0,537m is not expected.  
Die Leuchte soll so montiert werden, dass ein längerer direkter Augkontakt mit der LED aus einer Distanz von weniger als 0,537m vermieden wird.  
Per evitare il rischio di danni alla vista, l'apparecchio deve essere montato in modo che non si possa guardare direttamente la sorgente luminosa da una distanza inferiore a 0,537m per un tempo prolungato.  
La luminaria se tiene que instalar de tal forma que no se pueda mirar fijamente la fuente de luz por un tiempo prolongado a una distancia de menos de 0,537m, ya que pueda dañar los ojos

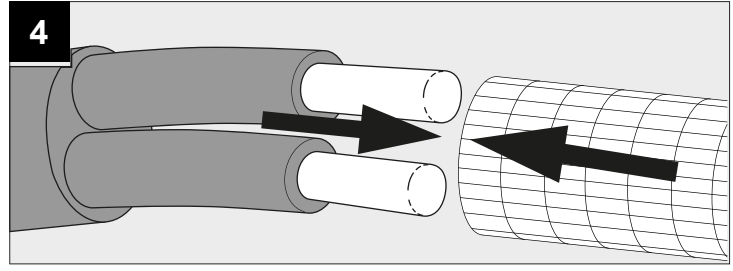
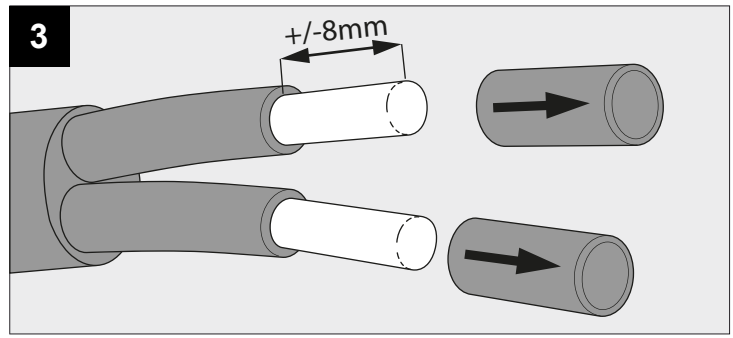

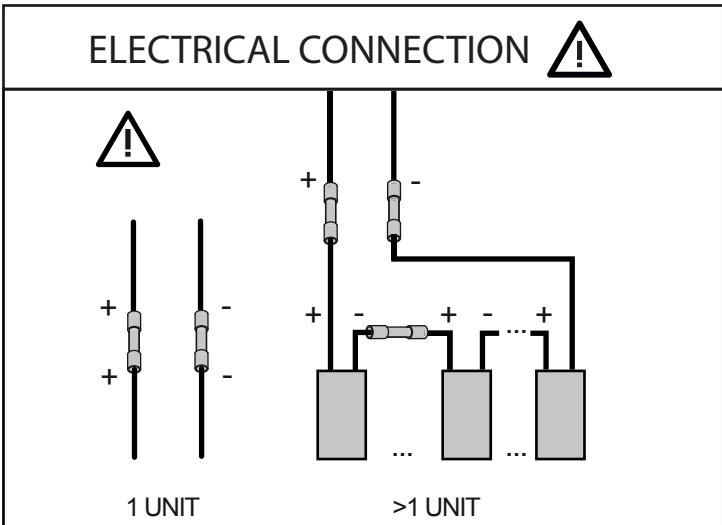
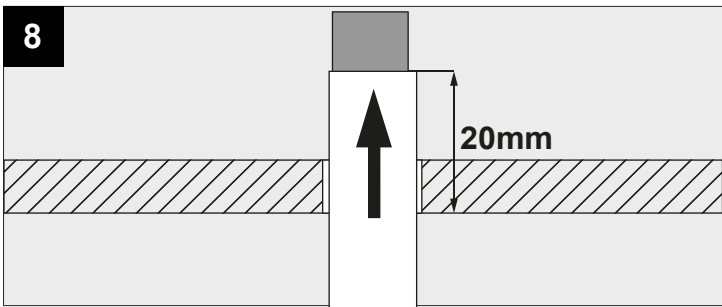
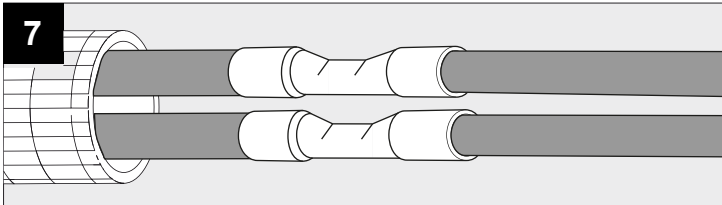
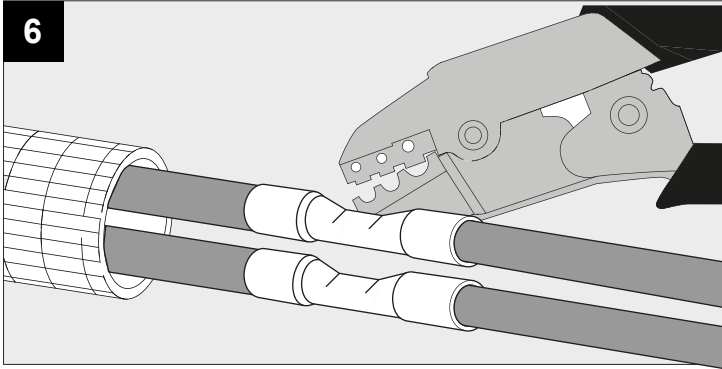
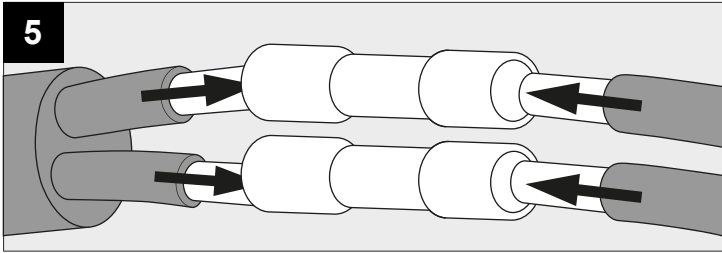

**ATTENTION**  
OBSERVE PRECAUTIONS FOR  
HANDLING ELECTROSTATIC  
DISCHARGE SENSITIVE  
DEVICES

NO SECONDARY SWITCHING

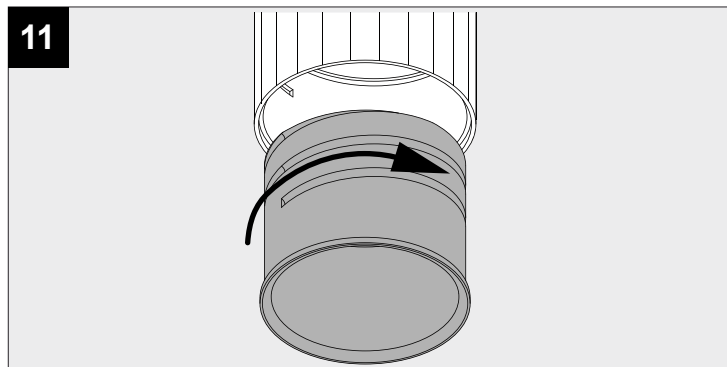
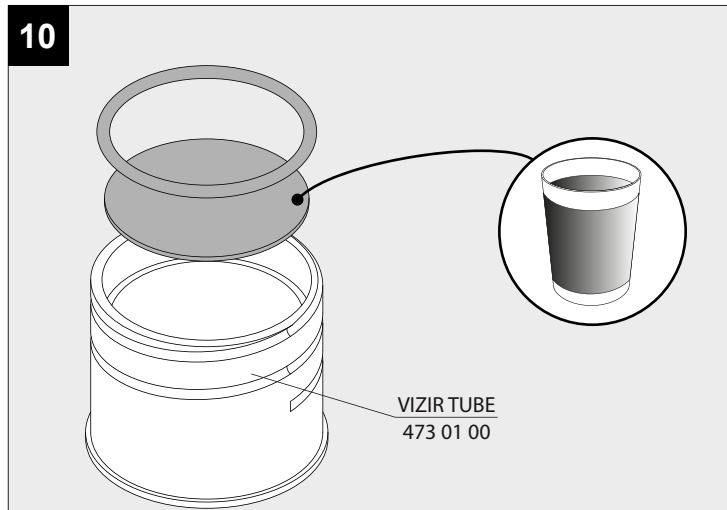
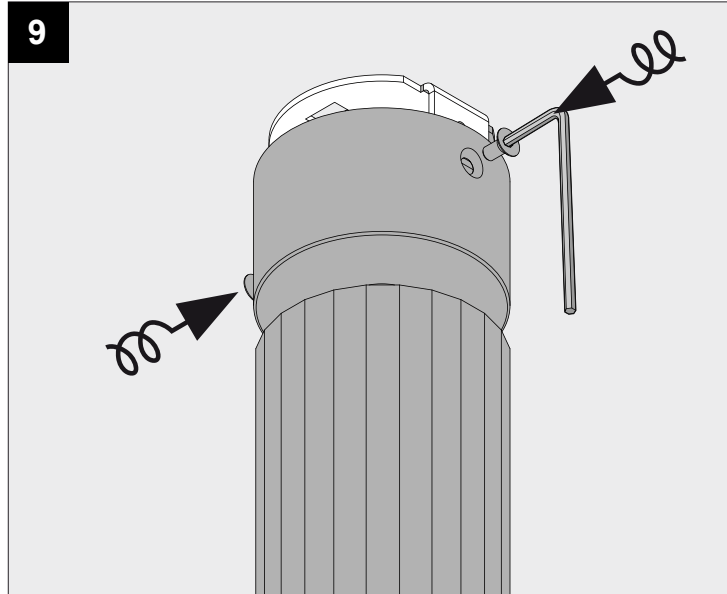

12

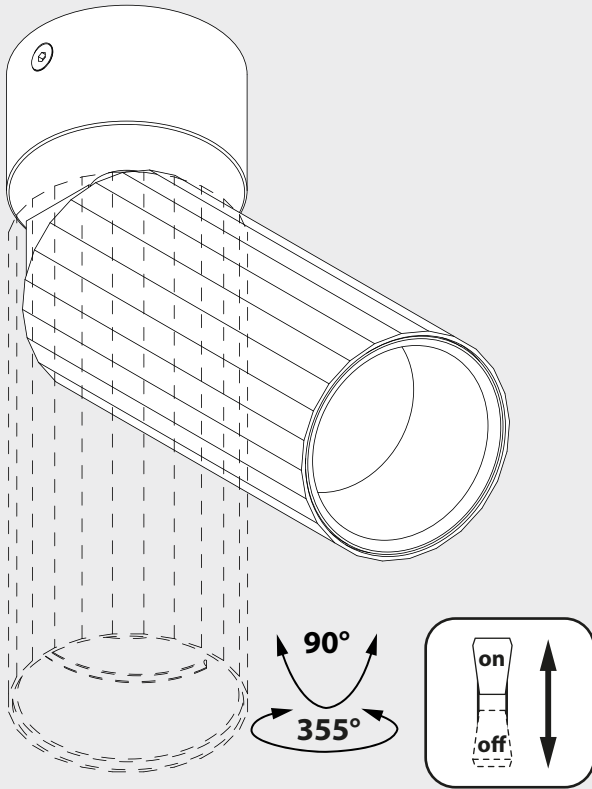

The luminaire should be positioned so that the prolonged staring into the luminaire at a distance closer than 537mm is not expected

De verlichtingsbron van dit verlichtingstoestel zal enkel door de fabrikant of door de fabrikant aangestelde installateur vervangen worden.

La source lumière de cet appareil ne sera remplacée que par l'entrepreneur ou par un agent reconnu.

Das enthaltene Leuchtmittel sollte nur durch entsprechendes Fachpersonal ersetzt werden.

The light source contained in this luminaire shall only be replaced by the manufacturer or his service agent.

La fuente de iluminación que tiene esta luminaria sólo puede remplazarse por el fabricante o por un instalador autorizado.

La sorgente luminosa incorporata in questo apparecchio può essere sostituita solo dal produttore, da un suo centro assistenza oppure da una persona in possesso della necessaria abilitazione.

ACCESSORIES

1

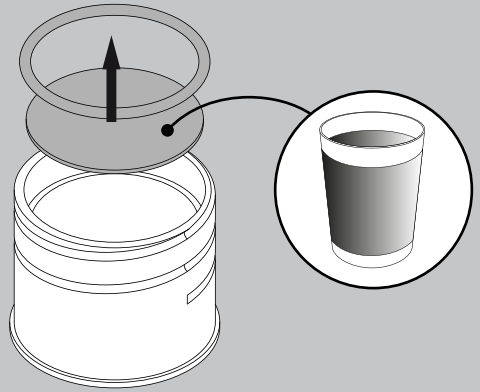

2

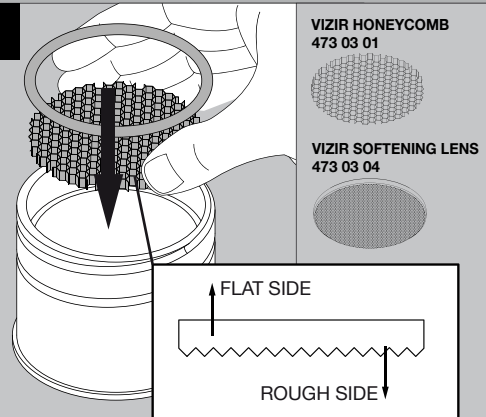

3

