



Swan pendant

TUNTO DESIGN
Tekijänkatu 8, FI-04440 Järvenpää, Finland
Tel. +358 10 421 3000
mail@tunto.com

TUNTO	swan pendant
	This luminaire contains built-in LED lamps.
	} LED
The lamps cannot be changed in the luminaire.	
	
874/2012	

Install in accordance with national and local electrical codes.
All installation works must be performed with specialized personnel.

PENDANT CABLE ASSEMBLY

Easy, adjustable ceiling installation.
The plastic-covered wire is 1,5 mm thick
with a maximum length of 5 m.

KABELINSTALLATION FÜR PENDELLEUCHTEN

Leichtes Anbringen an der Decke. Das
ummantelte Kabel ist 1,5 mm dick und hat eine
maximale Länge von 5 Metern.

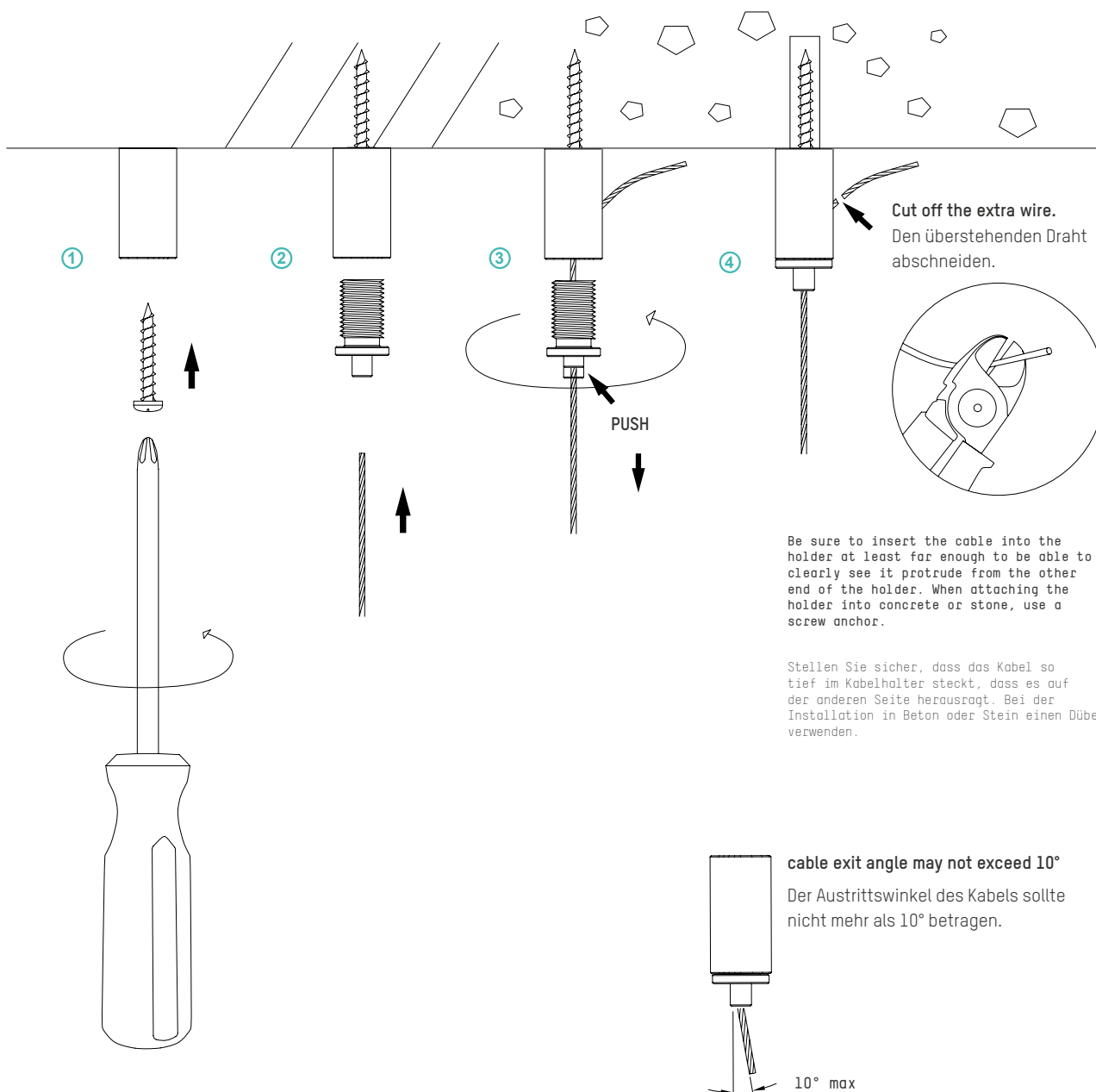

Install in accordance with national and local electrical codes.
All installation works must be performed with specialized personnel.

PENDANT POWER SUPPLY BOX

White ceiling cup RAL 9016 Standard 220 x 100 x 35mm.

PENDANT NETZTEIL

Deckenverkleidung in Weiß (RAL 9016), Standard: 220 x 100 x 35 mm.

ASSEMBLY

The power supply must be installed at a maximum of 5 m from the lamp into the wall, ceiling or to a specific location.

For more specific instruction see the driver data sheet.

Weitere Informationen finden Sie in der Bedienungsanleitung des Netzteils.

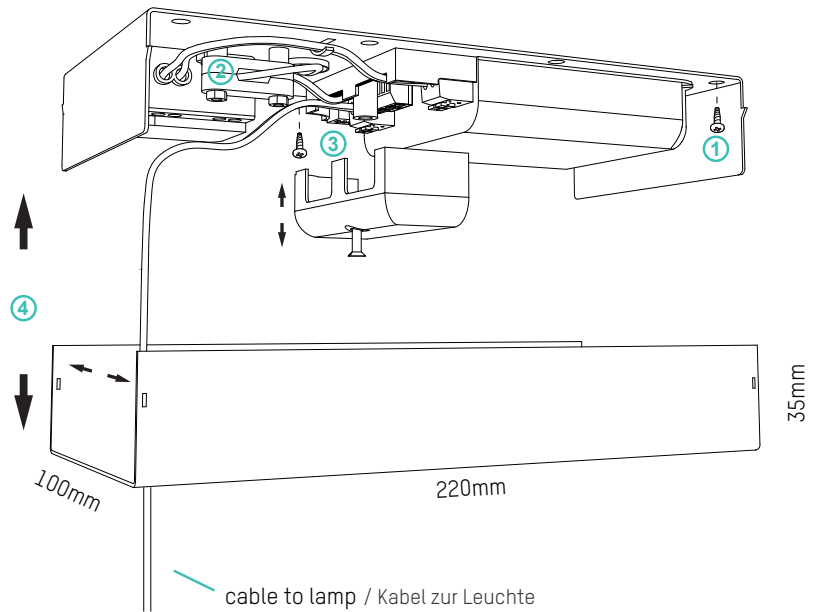

TOP VIEW

DALI / PUSH DIM

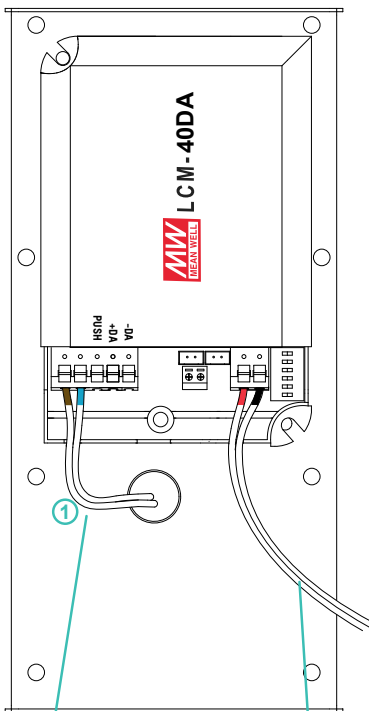

180-295V

L brown
N blue

cable to lamp + -
Kabel zur Leuchte

0-10V / PWM

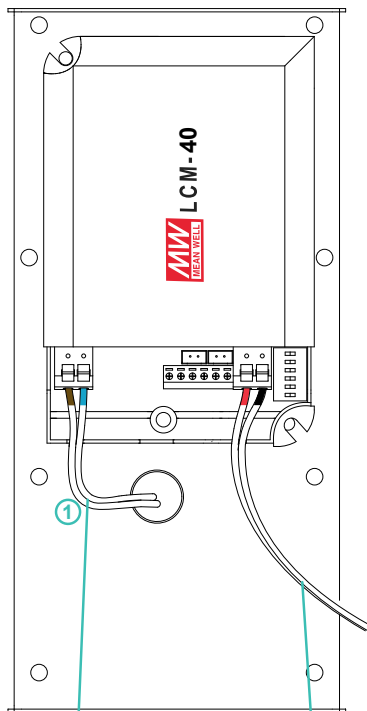

180-295V

L brown
N blue

cable to lamp + -
Kabel zur Leuchte

CASAMBI

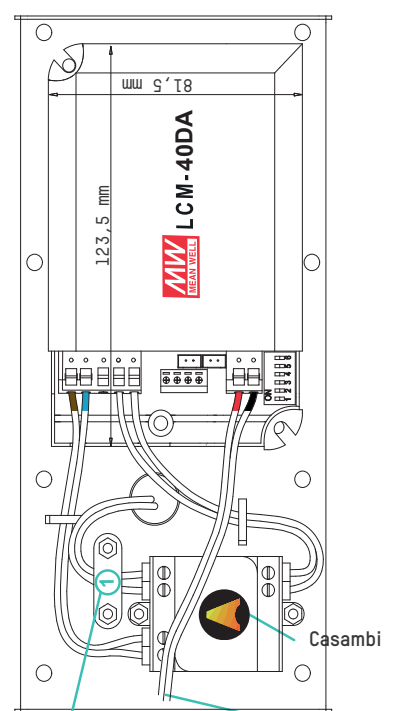

180-295V

L brown
N blue

+ -
cable to lamp
Kabel zur Leuchte

If you cut the lamp cable, the marking for +/- will disappear.
Just try which side works. Choosing a wrong side does not harm the light.

Install in accordance with national and local electrical codes.
All installation works must be performed with specialized personnel.

TRIAC

■ AC Dimming Operation

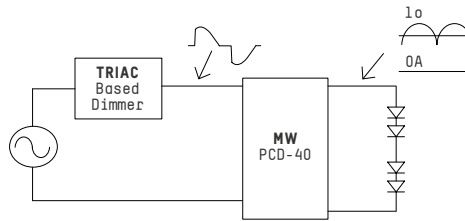

Tested compatible dimmers to PCD-60 Driver / Geprüfte compatible Dimmer für PCD-60-Schaltnetzteil

Manufacturer	Dimmer Model	
LUTRON	SKYLAR K SF-12P-27 7	(277VAC / 60Hz)
LUTRON	DVF-103P-277	(277VAC / 60Hz)
JUNG	Licht-Management 225 TDE	(230VAC / 50Hz)
JUNG	Licht-Management 225 NV DE	(230VAC / 50Hz)
BERKER	Tronic-Drehdimmer 286710	(230-240VAC / 50Hz)
CLIPSAL	32E450UDM	(220-240VAC / 50Hz)
CLIPSAL	NO 32E450TM	(220-240VAC / 50Hz)
CLIPSAL	NO 32E450LM	(220-240VAC / 50Hz)
CLIPSAL	Cat 400T	(230-240VAC / 50Hz)

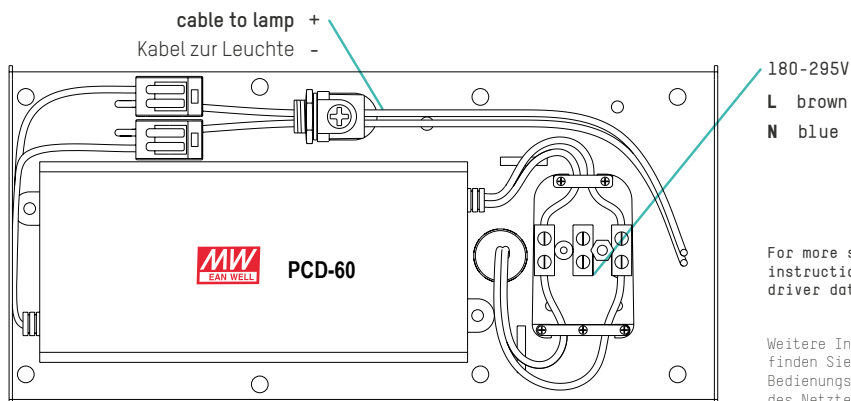
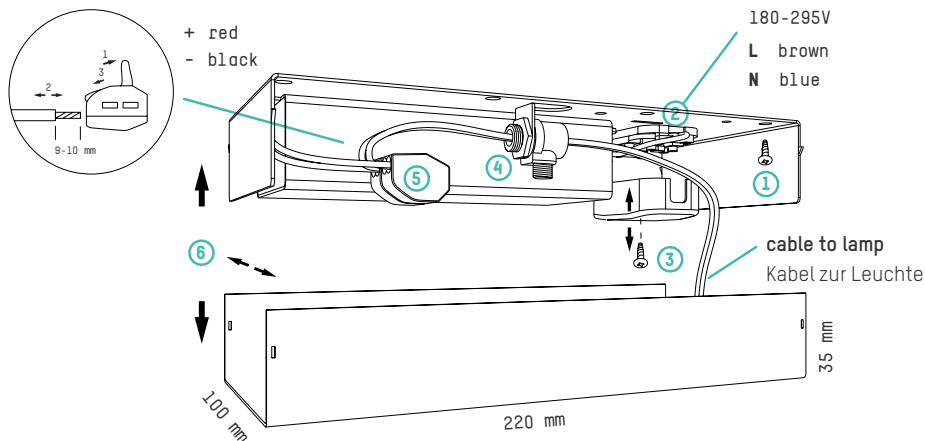

Install in accordance with national and local electrical codes.
All installation works must be performed with specialized personnel.

ANALOG

An analogue driver with in-built three-step dimming. On/off switch operation.

Analoges Netzteil mit eingebauter, dreistufiger Dimmbarkeit. Bedienung über On/Off-Schalter.

	Step 1	Step 2	Step 3
three-step analog dimming	Switch turn ON	Switch turn OFF ↓ Less than 2.5 seconds ↓ Switch turn ON	Switch turn OFF ↓ Less than 2.5 seconds ↓ Switch turn ON
percentage of rated current	100 %	40 %	10 %

NOTE: If the OFF time is longer than 2.5 seconds, once switch on again, PLM-40 will provide 100 % of rated output current

Hinweis: Steht das Gerät länger als 2,5 Sekunden auf OFF, werden beim nächsten Einschalten 100% Ausgangsstrom ausgegeben.

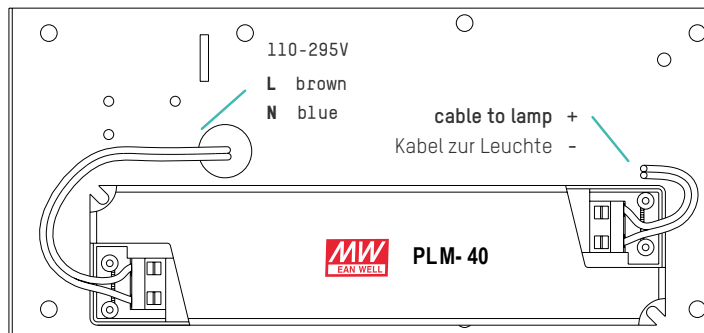

SLIM POWER SUPPLY BOX OPTION / SCHMALES NETZTEIL

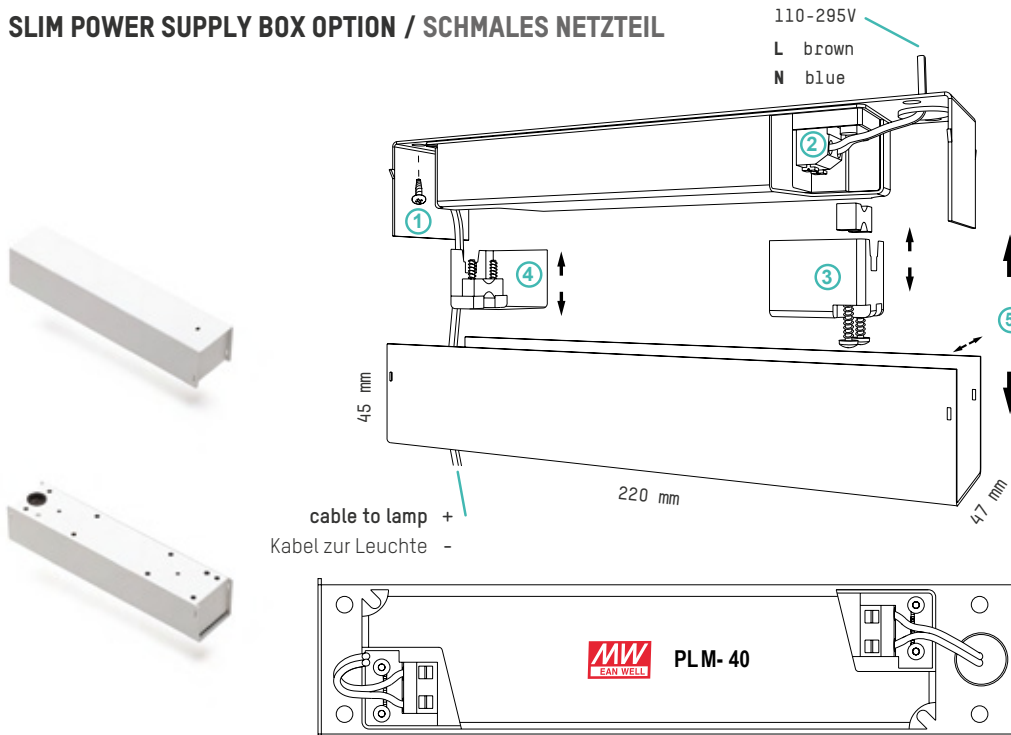

Install in accordance with national and local electrical codes.
All installation works must be performed with specialized personnel.

TECHNICAL SPECIFICATIONS / TECHNISCHE DATEN

Available colors and materials

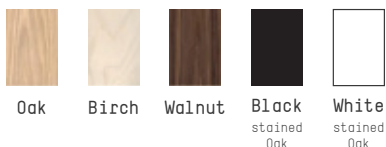

Surface Finish Lacquer

Swan Pendant 500mA lx measured 1.0 m on the table

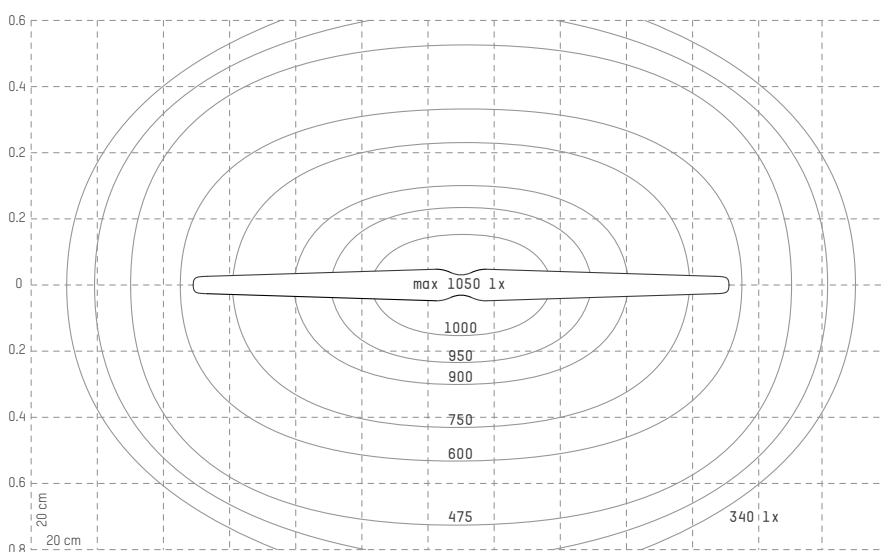

Drivers / Power Box

350 / 500 mA	DALI, PUSH DIM (standard)	LCM-40DA
	CASAMBI DIM	CAS
	0-10V / PWM	LCM-40

Drivers / Power Box

600 mA	DALI, PUSH DIM	LCM-60DA
	CASAMBI DIM	CAS
	0-10V / PWM	LCM-60

Other Drivers / External *

500 mA	TRIAC	PCD60
	ANALOG DIM (UL model)	PLM40

Rated Power	28-47W
Voltage	180-295V 50/60 Hz, UL model 110-295V
Output	350, 500, 600 mA
Cord Length	Standard 2 m, on request max 5 m, transparent
Power Box	White ceiling cup 220x100x35mm RAL 9003 fine efekt

Kelvin Lumen	2700 K, 3000 K (standard), 350 mA, 28 W / 2814 lm
	500 mA, 40 W / 3951 lm
	600 mA, 47 W / 4616 lm
CRI	85 Typ
Package Size	120 x 110 x 1660 mm
Package Weight	5,5 kg

INDOOR USE ONLY

NON-USER REPLACEABLE LIGHT SOURCE

IP20

CE

