

1 Scellement des tiges & fixation du mât

Install anchor J-Bolts in concrete foundation & fix the mast

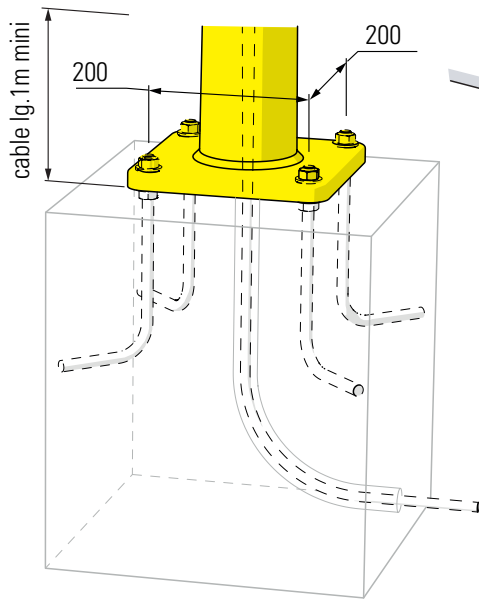

2 Montage des bras

Assemble the brackets

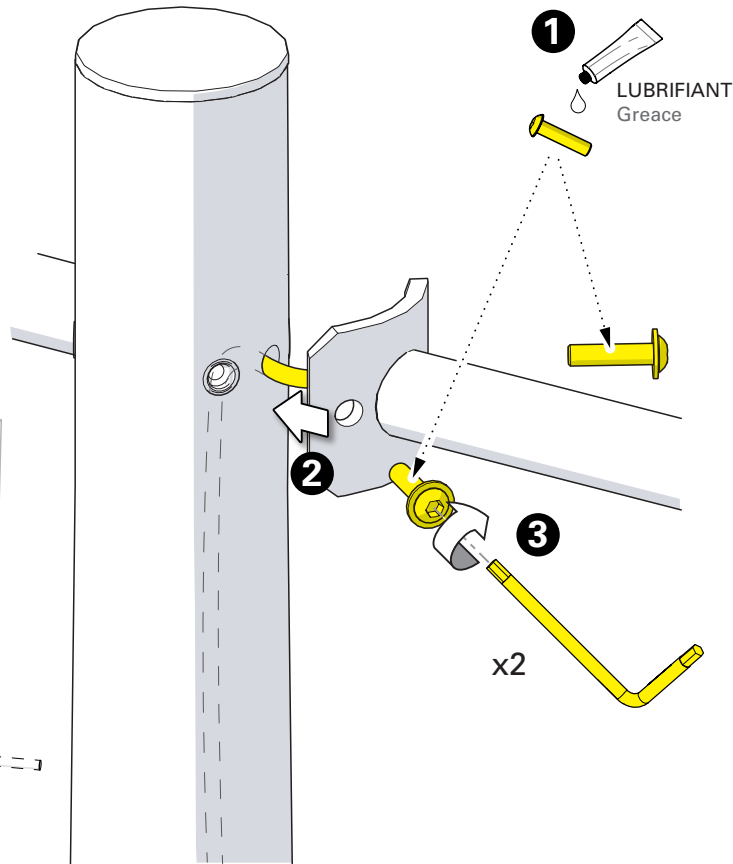

3 Raccordement électrique

Connect electrical wires

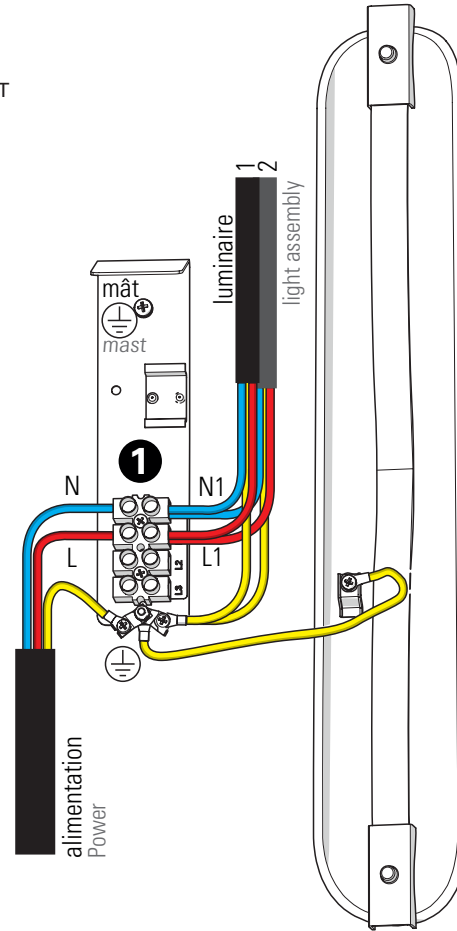

4 Fermeture de la trappe

Close the access door

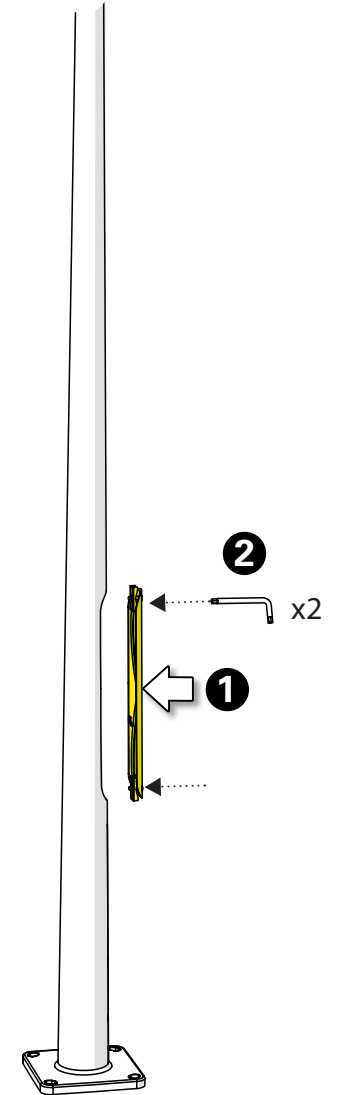

5 Montage de la lampe
Install the light-bulb

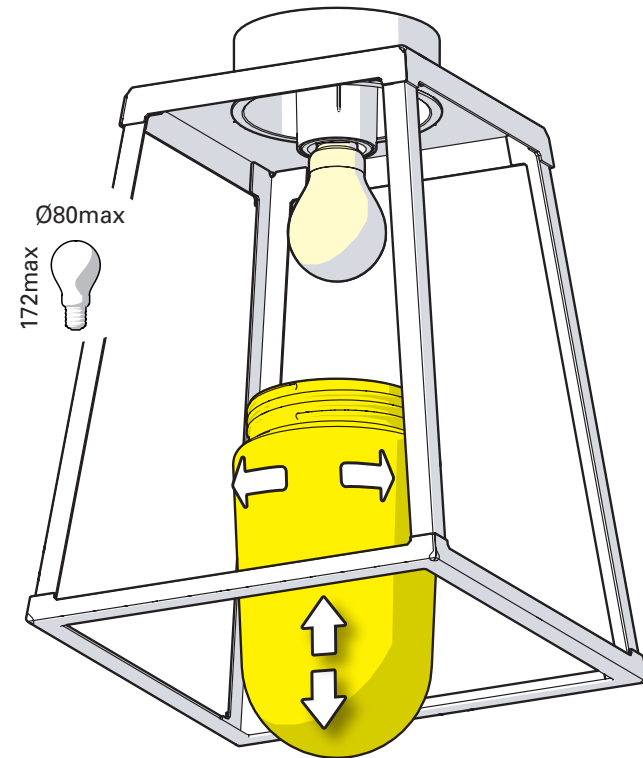

IP65

Visser délicatement le verre
pour une bonne adaptation du joint
Screw the glass diffuser softly to
ensure gasket correct positioning