

RF26254

Electronic touch dimmer

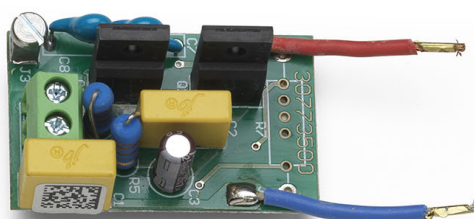

WARNING! When installing and whenever acting on the appliance, ensure that the power supply has been switched off.
For the installation of the spare-part, it is necessary to consult a qualified electrician.

RF26254

Electronic touch dimmer

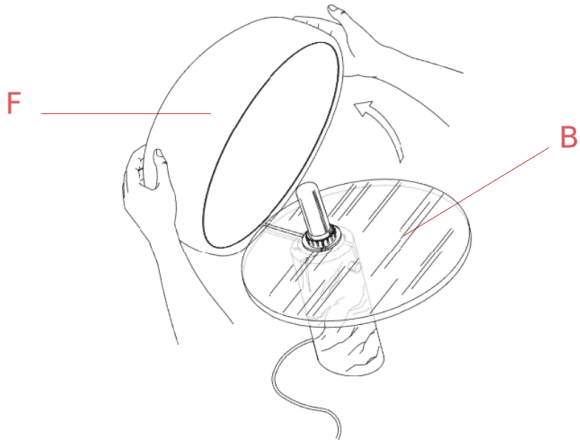

Fig.1

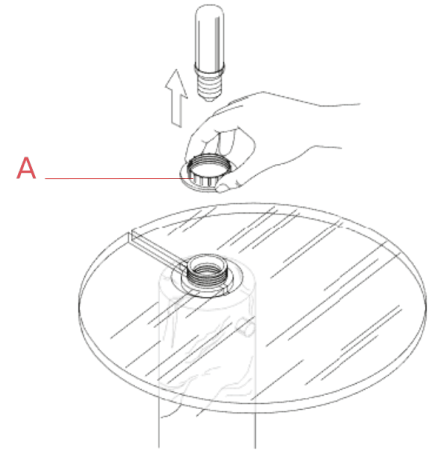

Fig.2

Remove the reflector (F) from the glass diffuser (B).
Remove the lamp-bulb and unfasten the locking ring nut (A).

WARNING! When installing and whenever acting on the appliance, ensure that the power supply has been switched off.
For the installation of the spare-part, it is necessary to consult a qualified electrician.

RF26254

Electronic touch dimmer

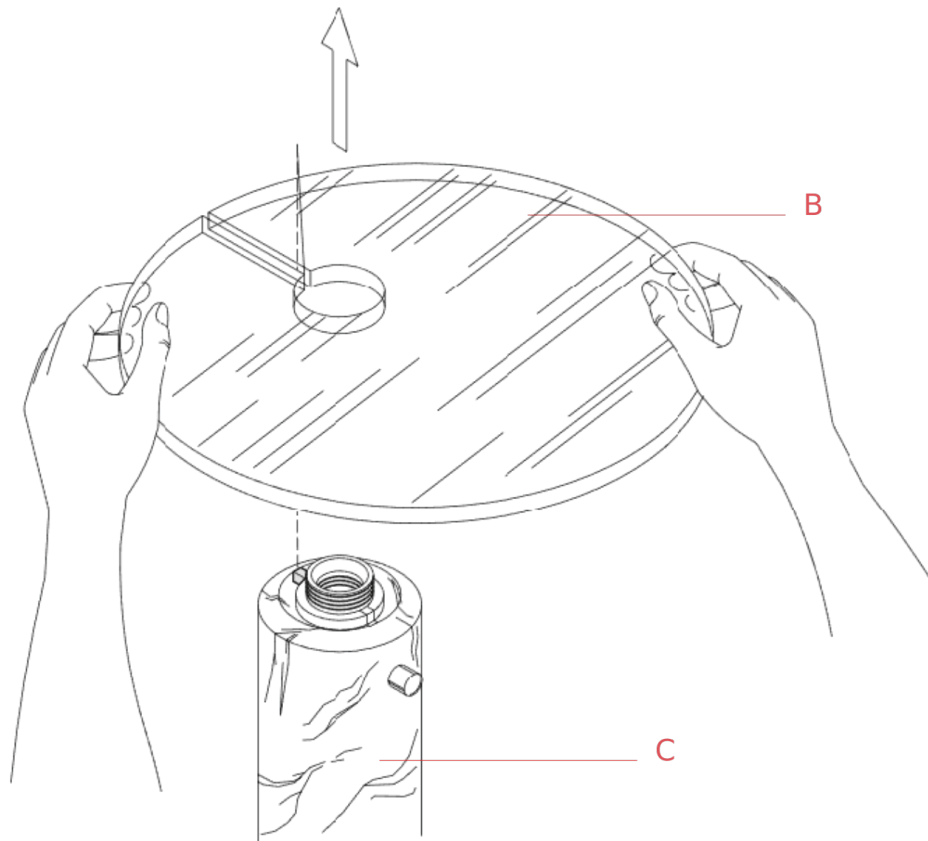

Fig.3

Delicately remove the glass diffuser (B) from the lamp body (C).

WARNING! When installing and whenever acting on the appliance, ensure that the power supply has been switched off. For the installation of the spare-part, it is necessary to consult a qualified electrician.

RF26254

Electronic touch dimmer



Fig.4



Fig.5

Turn upside down the lamp body (C) and remove the black base cover (D) by utilizing a flat screw driver.

By utilizing a tiny flat screw driver , carefully push towards the inside the side spring of the lamp holder in away to free the sleeve of the lamp holder.

WARNING! When installing and whenever acting on the appliance, ensure that the power supply has been switched off.
For the installation of the spare-part, it is necessary to consult a qualified electrician.

RF26254

Electronic touch dimmer



Fig.6

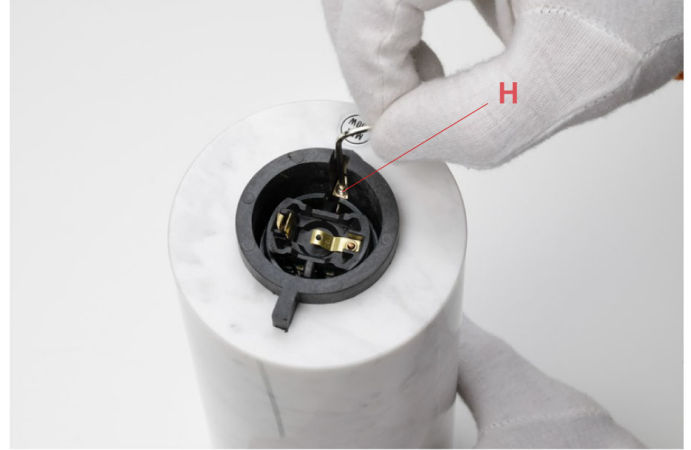

Fig.7

Remove the sleeve (G) from the lamp holder assembly by unfastening it.
Unfasten the locking screw (H) by utilizing an Allen key.

WARNING! When installing and whenever acting on the appliance, ensure that the power supply has been switched off.
For the installation of the spare-part, it is necessary to consult a qualified electrician.

RF26254

Electronic touch dimmer

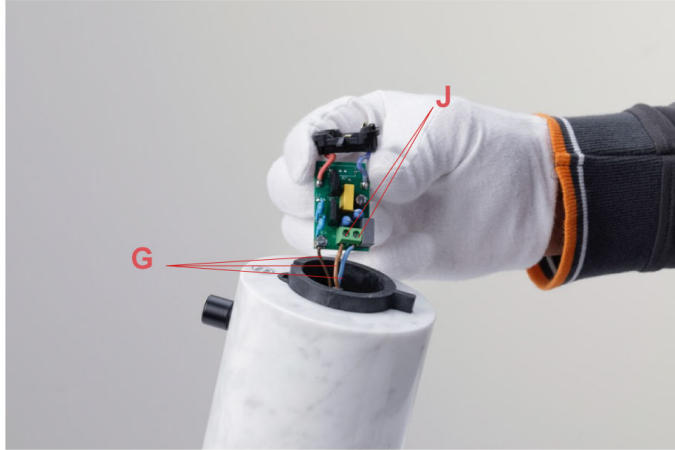

Fig.8

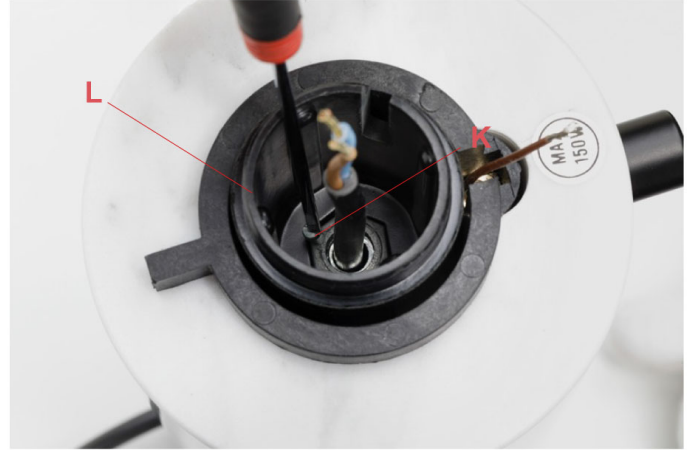

Fig.9

Lift up the lamp holder assembly with the touch dimmer (printed circuit board) from the lamp body and free the electrical cable assembly that needs to be replaced by disconnecting the electrical wires (I) through the terminals (J).

Assemble now the new spare part:

Connect the electrical wires (I) to the touch dimmer by respecting the polarities indicated in correspondence of the connection terminal (J).

Connect the Brown (live) wire in the terminal indicated with "L" and then connect the Blue (neutral) wire in the other terminal indicated with "N".

Position back the lamp holder assembly onto the lamp body and fasten back the locking screw (H) by utilizing an Allen key.

Screw back on the lamp holder the sleeve (G).

Turn upside down the lamp body (C) and place back the black base cover (D).

Place the glass diffuser (B) on the main body (C) ensuring that the groove (D) corresponds perfectly to the reference tooth (E).

Lock the glass diffuser (B) by fastening the locking nut (A) and insert the lamp bulb.

Position the reflector (F) on the glass (B) ensuring that the anti rotation tooth (G) is inserted in the groove of the glass diffuser.

WARNING! When installing and whenever acting on the appliance, ensure that the power supply has been switched off. For the installation of the spare-part, it is necessary to consult a qualified electrician.