

# LED linear lamp, opal

RL-RAL1 60 DIM 4,9W/230/827/O/S14D

# Radium

Product Datasheet Date: 26.11.2022

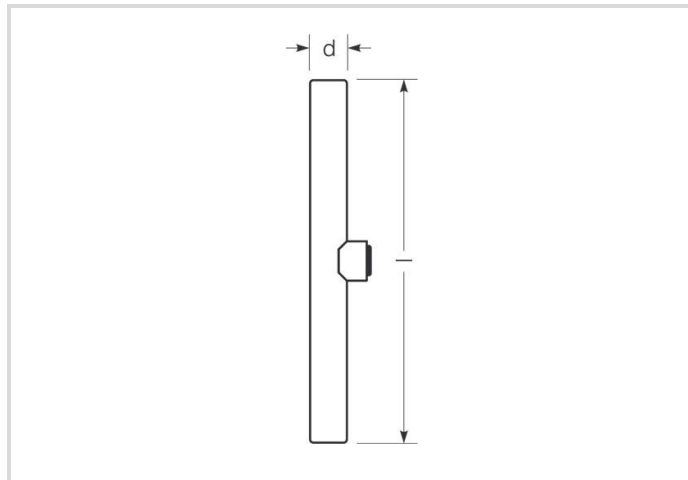

F



2700K



25 000h

## General Data

Article No.	43714956
Code	RL-RAL1 60 DIM 827/O
Product EAN	4008597149566
Customs tariff no.	85395200
Box quantity (pcs.)	10
EAN Box	4008597449567
Gross weight of box in kg	1.739
Length of box in m	0.568
Width of box in m	0.21
Height of box in m	0.15
ETIM class	EC001959
ETIM class name	LED-lamp/Multi-LED
Weight	125 g
Product status	 Active

## Electric Parameters

Rated wattage	4.9 W
Weighted energy consumption in 1,000 hours	5 kWh

## Electric Parameters

Nominal voltage	220-240 V
Voltage type	AC
Nominal current (mA)	29 mA

## Light Application Parameters

Luminous flux	470 lm
Rated luminous flux acc. IEC 62722-2-1	470 lm
Beam angle	200 °
Color temperature	2700 K
Colour rendering index CRI	80-89
Color rendering index Ra nominal	80
Color Stability	≤ 6 sdc <sub>m</sub>

## Service Life

Average nominal lifespan	25000 h
Mean service life	25000 h
Min. number of switching cycles	100000

## Specification

Energy Label A to G	F
Diameter	29 mm
Length max.	500 mm
Length	500 mm
Burning position	beliebig
Mercury content	0.0 mg
Lamp shape	Linear
Socket	S14d
Colour	White

## Notes on Operation

Degree of protection (IP)	IP20
Burning position	beliebig

## Information especially for EPREL

Lighting technology	LED
Color tunable light source	No

# LED linear lamp, opal

RL-RAL1 60 DIM 4,9W/230/827/O/S14D

# Radium

## Notes

RaLEDina, LED lamp for exchange with linear incandescent lamps, coated glass bulb, dimmable, base S14d. LED light does not contain UV or IR radiation.

Please, refer to [www.radium.de/recycling](http://www.radium.de/recycling) for notes on disposal of burned-out lamps as well as lamp breakage.

The "lifespan L70" described for LED lamps indicates the number of hours when the luminous flux has decreased to 70% of its initial value.

The optimal field 'info about service life' contains the frame conditions according to standards based on which the specific service life has been determined. So, for example, "12B50, 50Hz" means that the mean service life (B50) has been determined with a 12h switching cycle at mains (frequency 50Hz), "3B50, HF" is based on a 3h switching cycle at electronic control gear (high frequency).

## Base



S14d  
IEC/EN 60061-1  
sheet 7004-112-1

## Spectrum

As daylight is a mixture of direct sunlight and light from the sky, the spectral distribution changes all the time due to the time of the day and the weather. The standard illuminant D65 corresponds to daylight with colour temperature of about 6500K.

The colour of coloured LEDs depends on the chemical elements within the light generating chip. The coloured light is generated directly and does not need filtering.

White LEDs are either RGB (red + green + blue chip in one LED = light colour white) or blue LED-chips with yellow/orange phosphor in the resin.

Visible region from 380 to 780 nm; height of graph corresponding with relative spectral emission (400mW/klm)per 10nm.

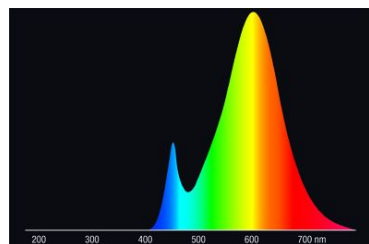

RaLEDina: LED retrofit for Linear incandescent lamp 2700K

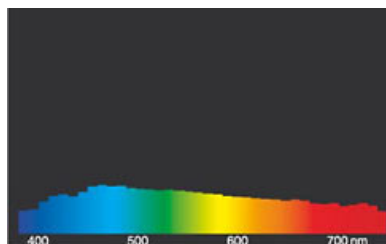

daylight(D 65)

## Special features



## General notes

For LED replacement of halogen and incandescent lamps, we recommend direct replacement (1: 1) at the respective burning position. For new systems, the number of lamps in the circuit operated at control gear such as transformers or dimmers can be obtained from corresponding compatibility lists (if available). If there is no specification for the type of device or lamp required, for safety reasons, the replacement power shall be assumed as that of the original halogen type (eg "RL-MR16 35" -> 35W, independent of the real power consumption).

The technical design data in accordance with DIN and IEC. The producer does not take any responsibility for damage to persons or property in case of unsuitable operation or handling of the product. Operating data and dimensions are valid within the usual tolerances. Related lamp types (different bases, mains voltages) may be available on request. Sale and delivery are effected in accordance with the Radium Terms of Delivery and Payment valid on the day of conclusion of contract. Packing units offer economical advantages to the purchase and logistic department. Please match your quantity volume accordingly. For orders of a minimum quantity (clefs) with a lamp model the amount lower than the volume of each packaging unit, we will invoice 10 % additional charge per lamp type. Technical changes and terms of delivery are reserved. Manipulation of any kind to packaging or product is not permissible as this will violate Radium brand rights. Furthermore, technical properties of the product can change to its disadvantage or even destruction. Therefore, Radium cannot be responsible for consequential damages.

® = Registered trademark

Subject to change without notice. Errors and omissions excepted.

## Safety instructions

To ensure full light efficiency and product life, the permissible temperature ranges must be observed and dry environment ensured. When operated with existing control gear, their compatibility with the lamp must be checked.

## **LED linear lamp, opal**

RL-RAL1 60 DIM 4,9W/230/827/O/S14D

# **Radium**

All technical data without guarantee.