

Perseo

ISTRUZIONI DI MONTAGGIO
ASSEMBLY INSTRUCTIONS
INSTRUCTION DE MONTAGE
MONTAGEANLEITUNG
ИНСТРУКЦИЯ ПО МОНТАЖУ

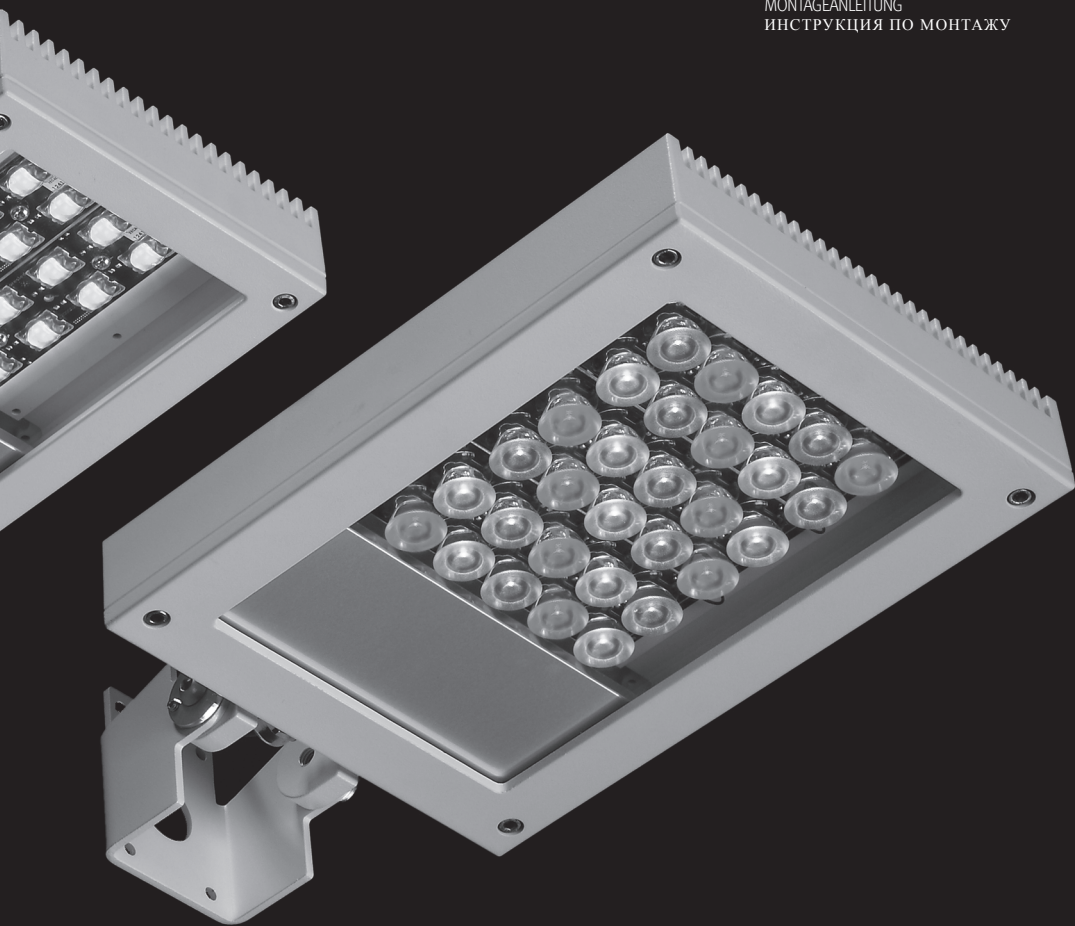



ITA. E' obbligatorio che l'installazione e la messa in servizio dell'apparecchio vengano effettuate da personale qualificato nel rispetto delle norme vigenti.

UK. Connection and maintenance of the luminaire must be carried out by trained and qualified staff only, in compliance with the regulation in force.

ESP. El montaje del aparato y las fases de manutención que intervienen en el mismo, deben ser seguidas por personal cualificado.

FR. L'installation et la maintenance de l'appareil doivent être confiées à du personnel qualifié.

DE. Der Anschluss der Leuchte und die entsprechenden Wartungsarbeiten dürfen ausschließlich von qualifizierten Fachleuten durchgeführt werden.

RU. Сборка и установка должны производиться только специально обученными квалифицированными специалистами.

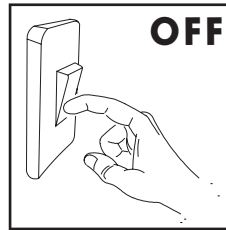

ITA. Prima di effettuare qualsiasi intervento sugli apparecchi togliere l'alimentazione elettrica.

UK. Make sure there is no power connected to the fitting before carrying out any maintenance.

ESP. Antes de manipular el aparato, desconectar la alimentación eléctrica.

FR. Avant de procéder à toute opération, toujours couper l'alimentation électrique et s'assurer qu'elle ne peut pas être rétablie accidentellement.

DE. Vor Durchführung sämtlicher Arbeiten an der Leuchte, ist der Netzstecker vom Stromanschluss zu trennen.

RU. Убедитесь, что осветительный прибор не подключен к источнику питания, прежде чем начать любые ремонтные действия.



ITA. Non installare il prodotto in caso di pioggia, nebbia o forte umidità.

UK. Do not install the luminaire in case of rain, fog or intense humidity.

ESP. No instalar el producto en caso de lluvia, niebla o situaciones de alta humedad.

FR. N'installez pas l'appareil en présence de pluie, brouillard ou humidité intense.

DE. Die Leuchte nicht bei Regen, Nebel oder hoher Luftfeuchtigkeit installieren.

RU. Не проводите установку светильника в дождь, туман и при повышенной влажности.

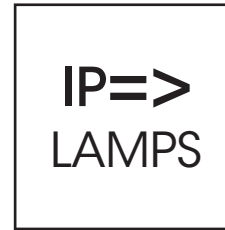

ITA. Il sistema di connessione per gli apparecchi IP deve avere un grado di protezione uguale o superiore al grado IP dell'apparecchio.

UK. The protection rating of the electrical connection must be equal to or greater than the IP rating of the luminaire.

ESP. El sistema de conexión para los aparatos IP deben tener un grado de protección igual o superior al grado IP del aparato.

FR. Le degré de protection de la connexion électrique doit être égal ou supérieur du degré IP de l'appareil.

DE. Die Schutzklasse von den elektrischen Anschlüssen muss gleich oder größer sein als die Schutzklasse der Leuchte selber.

RU. Степень защиты электрических соединений должна быть равной или превосходить IP степень прибора.

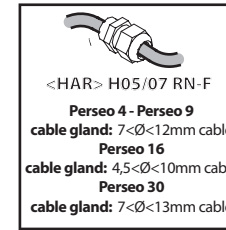

ITA. Utilizzare un cavo di alimentazione con tipologia idonea (cavi flessibili HAR H05/07 RN-F o idonei per l'utilizzo all'esterno); i cavi rigidi possono compromettere la tenuta attraverso il pressacavo.

UK. Use HAR H05/07 RN-F flexible cables or dedicated cables for outdoor use only. Stiff cables do not assure the effectiveness of the cable gland.

ESP. Utilizar un cable de alimentación adecuado para instalaciones de exterior (tipo HAR H05/07 RN-F). Los cables rígidos pueden comprometer la estanqueidad del prensaestopas.

FR. Utiliser seulement des câbles souples type <HAR> H05/07 RN-F ou spécialement conçus pour un usage à l'extérieur. L'emploi de câbles rigides risque de compromettre l'étanchéité du presse-étoupe.

DE. Für den Außenbereich dürfen nur flexible Kabel vom Typ <HAR> H05/07 RN-F oder typengleiche Kabel verwendet werden. Starre Kabel können den Halt des Kabels in der Kabeldurchführung nicht gewährleisten.

RU. Используйте гибкие кабели HAR H05/07 RN-F, или кабели, предназначенные для использования вне помещений. Силовые кабели постоянного тока не гарантируют качество кабельная муфта.

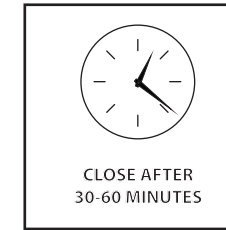

ITA. Fare funzionare gli apparecchi aperti per 30-60 minuti prima di chiuderli.

UK. Switch the luminaire on and let it work for 30-60 minutes before closing it.

ESP. Encender el aparato estando abierto, durante 30-60 minutos antes de cerrarlo completamente.

FR. Allumez l'appareil et laissez-le en fonction pour 30-60 minutes avant de le fermer et terminer l'installation.

DE. Die Leuchten vor Verschließen ca. 30-60 Minuten offen brennen lassen.

RU. Перед закрытием включите светильник на 30-60 минут.



ITA. Pulire periodicamente gli apparecchi per rimuovere gli accumuli di sporco che si depositano sulle griglie e nella testa delle viti. Pulire le parti in acciaio utilizzando appositi detergenti.

UK. Keep the luminaire clean to prevent dirt deposit on frames and screws' head. On steel parts use dedicated cleaners only.

ESP. Limpiar periódicamente los aparatos para retirar la acumulación de sedimentos depositados sobre los aros y las cabezas de los tornillos. Limpiar las partes de acero utilizando el detergente adecuado.

FR. Nettoyez l'appareil périodiquement pour éviter l'oxidation de la collerette et des vis. Nettoyez les parties en acier avec des produits spécifiques.

DE. Die Leuchten regelmäßig vom Schmutz befreien, der sich auf den Rastern und den Schraubenköpfen ansammelt. Edelstahlteile nur mit dafür geeigneten Mitteln reinigen.

RU. Содержите светильник в чистоте, избегайте накопления грязи на рамке и головках винтов. Для стальных деталей используйте только соответствующие средства.

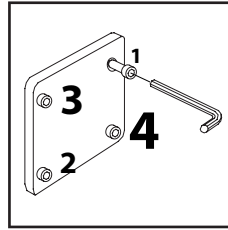

ITA. Bloccare e sbloccare le viti di chiusura con sequenza alternata.

UK. Tighten and release screws alternately or crosswise.

ESP. Apretar y aflojar los tornillos de cierre de modo alterno.

FR. Vissez et dévissez les vis en diagonale.

DE. Verschlußschrauben über Kreuz öffnen und schließen.

RU. Закручивайте и выкручивайте винты не сразу до конца, а постепенно поочередно или крест-накрест.

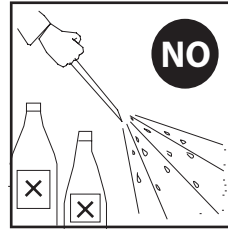

ITA. Nessuna parte dell'apparecchio, deve stare a contatto diretto con sostanze chimiche aggressive (es. fertilizzanti, diserbanti, calce).

UK. Keep away from aggressive agents and chemical substances (e.g. fertilizer, weed-killer, lime).

ESP. Ninguna parte del aparato debe estar en contacto directo con el terreno o con sustancias químicas agresivas (fertilizantes, herbicidas, cal, etc).

FR. Gardez l'appareil à l'abri de toute substance chimique agressive (engrais, désherbant, chaux).

DE. Die Leuchte darf nicht mit chemischen oder aggressiven Substanzen (wie z.B. Düngemittel, Unkrautvertilgungsmittel, Kalk) in Kontakt kommen.

RU. Необходимо избегать агрессивных веществ. При установке внешние детали светильника должны быть защищены от прямого контакта с агрессивными и химическими веществами (удобрения, гербициды, лимон и т.д.).

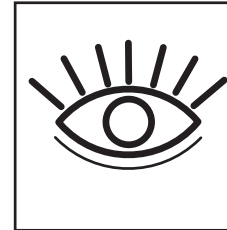

ITA. Gruppo di Rischio 1

UK. Risk Group 1

ESP. Grupo de riesgo 1

FR. Groupe de risque 1

DE. Gefährgruppe 1

RU. Группа риска 1

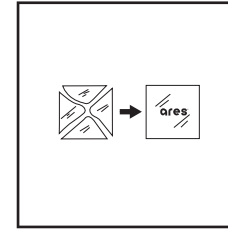

ITA. Sostituire il vetro/diffusore con ricambio originale ARES in caso di rottura.

UK. In case of break of the glass/diffuser use original ARES spare parts only.

ESP. En caso de rotura del cristal/difusor, substituirlo por recambios originales ARES.

FR. Remplacez le verre/diffuseur cassé par des pièces de rechange originales ARES.

DE. Defekte gläser/diffuser durch original ARES Ersatzteile ersetzen.

RU. Производите замену разбитого стекла ARES только оригинальными запасными частями.

ITA. Per tutti gli apparecchi di illuminazione deve essere effettuata a cadenza programmata la manutenzione dell'installazione (norma CEI 64-8) che deve prevedere le seguenti operazioni:

- Verificare il serraggio delle viti che fissano le varie parti dell'apparecchio;
 - Verificare l'integrità di tutti i pressacavi e dei cavi;
 - Verificare il serraggio dei pressacavi;
 - Verificare l'integrità e l'elasticità delle guarnizioni che non devono risultare danneggiate;
 - In caso di componenti danneggiati essi vanno sostituiti prima di rimettere in servizio l'apparecchio utilizzando solo ricambi originali.
- Si consiglia di effettuare controlli ad ogni sostituzione di lampada o almeno ogni anno, scegliendo il periodo più breve in relazione al tipo di impianto. E' vietato l'uso improprio dell'apparecchio o ogni manomissione del prodotto o modifica non autorizzata dalla casa costruttrice (in caso contrario decade ogni forma di garanzia e responsabilità).
- Nel caso in cui ARES dia il consenso al reso degli apparecchi per il controllo, essi dovranno essere restituiti lasciando un pezzo di cavo di alimentazione di 10/20 cm uscente dall'apparecchio.

UK. All luminaires have to undergo regular maintenance (CEI 64-8 standards) according to the following steps:

- Check the fastening of the screws.
 - Inspect cables and cable glands for any possible damage.
 - Check the fastening of cable glands.
 - Check if seals are in working order.
 - Defect or damaged components must be replaced before switching the luminaire on. Use original spare parts only.
- It is important to carry out luminaire maintenance at each bulb substitution or at least once per year.
- Any improper use or installation, any tampering or any unauthorised modification of the luminaire causes the immediate expiry of the warranty on the luminaire and of any claim against the manufacturer.
- Should Ares allow the return of a luminaire for technical inspection or tests, they must be returned with a piece of wiring cable (10-20cm connected to the luminaire).

ESP. Para todos los aparatos de iluminación, debe programarse un mantenimiento de la instalación (Norma CEI 64-8) que prevee las siguientes operaciones:

- Verificar el par de apriete de los tornillos que fijan las diferentes partes del aparato.
 - Verificar la integridad de todos los prensaestopos y de los cables.
 - Verificar el par de apriete del prensaestopos.
 - Verificar la integridad y elasticidad de las juntas de goma. En ningún momento pueden estar dañadas.
 - En caso de componentes dañados, se sustituirán siempre por recambios originales antes de volver a poner en servicio el aparato.
- Se aconsejan controles en cada sustitución de la lámpara o al menos una vez al año, lo que antes suceda, en función del tipo de instalación.
- Está prohibido el uso inadecuado del aparato, manipulación del producto o modificación no autorizada del cuerpo constructivo (en caso contrario decaerá la garantía y responsabilidad por parte de ARES).
- En el caso de que ARES acepte una devolución del aparato para su examen, se deberán enviar dejando un trozo de cable de la alimentación saliendo del aparato de al menos 10/20 cms.

FR. Programmez régulièrement l'entretien des appareils (CEI 64-8) selon les étapes suivantes:

- Contrôlez le serrage des vis.
 - Contrôlez l'intégrité du câble et du presse-étoupe.
 - Contrôlez le serrage du presse-étoupe.
 - Contrôlez l'intégrité des joints.
 - Avant d'allumer l'appareil remplacez tous composants endommagés par des pièces de rechange originales.
- Effectuez l'entretien de l'appareil après chaque remplacement de l'ampoule ou au moins une fois par an.
- La garantie perd toute validité en cas d'utilisation ou installation inexacte ou de modification non autorisée de l'appareil.
- En cas de retour de l'appareil pour contrôle technique, après autorisation de Ares, veuillez le rendre avec un morceau de câble de 10-20cm connecté à l'appareil.

DE. Bei allen Leuchten gilt es, in festgelegten Rhythmen, Installationswartungen durchzuführen (Norm CEI 64-8). Diese beinhalten folgenden Aktionen:

- Prüfen der Anzugskraft der Schrauben, die die einzelnen Teile der Leuchte verbinden.
 - Überprüfen der Kabelklemmen und Kabel auf Defekte.
 - Anzugskraft der Kabelklemmen prüfen.
 - Prüfen der Unversehrtheit und Elastizität der Dichtungen, sie dürfen nicht gequetscht sein.
 - Beschädigte Komponenten durch Originalteile austauschen, bevor die Leuchte erneut in Betrieb genommen wird.
- Es wird empfohlen, bei jedem Leuchtmitteltausch oder wenigstens einmal pro Jahr, die Kontrolle durchzuführen. Bei Leuchtmitteln mit kürzerer Lebensdauer genügt hingegen eine jährliche Durchsicht.
- Missbräuchliche Verwendung, jegliche Produktfälschung oder Änderungen, die vom Hersteller nicht genehmigt wurden, sind verboten (dies entgegengesetzt verfällt jede Garantie und Haftung).
- Im Reklamationsfall müssen die Leuchten mit einem 10-20 cm langen Stück montiertem Stromkabel zurück geschickt werden, sofern Ares seine Zustimmung zum Retournieren gibt und sie überprüft.

RU. Все светильники должны подвергаться регулярному обслуживанию (стандарт CEI 64-8) согласно следующим пунктам:

- Проверьте, достаточно ли плотно закручены винты.
 - Осмотрите кабели и кабельные входы на возможные повреждения.
 - Проверьте, достаточно ли плотно затянуты кабельные вводы.
 - Проверьте, на своих ли местах находятся прокладки и изоляция.
 - Поврежденные или неисправные детали должны быть заменены до включения светильника. Используйте только оригинальные запасные части.
- Важно выполнять осмотр светильника при каждой замене лампы или, по крайней мере, один раз в год.
- Любые неправильные установка или использование, любые манипуляции или несанкционированное изменение прибора являются основанием для немедленного снятия прибора с гарантии и отказа заводом в удовлетворении любых претензий.
- В случаях если ARES позволил вернуть светильник для технической инспекции или тестов, он должен быть возвращен с кабелем питания (не менее 10-20 см соединенные со светильником).

IP65     

525012	NATURAL WHITE POWER LEDs 4,4W/100~240V/50~60Hz Total power 7W Integral electronic power supply
525013	WARM WHITE POWER LEDs 4,4W/100~240V/50~60Hz Total power 7W Integral electronic power supply
525022	NATURAL WHITE POWER LEDs 4,4W/100~240V/50~60Hz Total power 7W Integral electronic power supply
525023	WARM WHITE POWER LEDs 4,4W/100~240V/50~60Hz Total power 7W Integral electronic power supply
525002	NATURAL WHITE MID-POWER LEDs 6,6W/100~240V/50~60Hz Total power 9W Integral electronic power supply
525003	WARM WHITE MID-POWER LEDs 6,6W/100~240V/50~60Hz Total power 9W Integral electronic power supply

ITA. La sicurezza dell'apparecchio è garantita solo rispettando le normative europee del settore elettrico e le istruzioni contenute in questa scatola: pertanto è necessario conservarle. Il rispetto di queste istruzioni è fondamentale per il corretto funzionamento dell'apparecchio e dell'impianto.



UK. For safety to be assured, the fitting has to be installed and used properly, in compliance with EU Regulations and Directives on electrical and electronic equipments and with the mounting instructions included in the present box: please keep this instruction data sheet for future reference.



ESP. La seguridad del aparato se garantiza únicamente respetando las normativas europeas del sector eléctrico y las instrucciones contenidas en esta caja, por lo tanto es necesario conservarlas. La observación de estas instrucciones es fundamental par el correcto funcionamiento del aparato y de la instalación.



FR. La sécurité de l'appareil ne peut être assurée que par un strict respect des Normatives Européennes sur les équipements électriques et des instructions suivantes. Gardez ces instructions pour des consultations ultérieures.



DE. Die Leuchtensicherheit ist nur gewährleistet, wenn die europäischen Normen des Elektroniksektors und die hier beigelegte Montageanleitung befolgt werden. Aus diesem Grund sollte sie aufbewahrt werden. Die Beachtung der Anleitung ist Voraussetzung für die einwandfreie Funktion der Leuchte und der Installation.

RU. Для соблюдения мер безопасности убедитесь, что прибор будет установлен и использоваться согласно настоящей инструкции в соответствии с нормами и правилами ЕС по электричеству и электрооборудованию. Пожалуйста, сохраните инструкцию для будущих обращений.



ITA. -Stagno alla polvere e protetto contro i getti d'acqua IP65
-Idoneo per montaggio su superfici normalmente infiammabili ▽
-Apparecchio di classe II, 
-Marcatura 

UK. -Dust-tight and protected against waterjets IP65
- Suitable for installation on normally flammable surfaces ▽
-Class II,  lighth fixture
- Marking

ESP. -Protección contra el polvo y salpicaduras de agua IP65
-Idóneo para instalación en superficies normalmente inflamables ▽
-Luminaria de clase II, 
-Marcado 

FR. -Étanche aux poussières et protégé contre les jets d'eau IP65
-Peut être installé sur surfaces normalement inflammables ▽
-Appareil de classe II, 
-Marquage 

DE. -Staubdicht. Schutz gegen Strahlwasser aus allen Richtungen IP65
- Die Leuchte kann auf normal brennbaren Oberflächen installiert werden ▽
- Schutzklasse II, 
- Kennzeichnung 

RU. -пыленепроницаем и защищен от капель IP65
-подходит для установки на воспламеняющихся поверхностях ▽
-светильник Class II, 
-Маркировка 



PERSEO 9

525042	NATURAL WHITE POWER LEDs 9,9W/220-240V/50-60Hz Total power 12W Integral electronic power supply
525043	WARM WHITE POWER LEDs 9,9W/220-240V/50-60Hz Total power 12W Integral electronic power supply
525052	NATURAL WHITE POWER LEDs 9,9W/220-240V/50-60Hz Total power 12W Integral electronic power supply
525053	WARM WHITE POWER LEDs 9,9W/220-240V/50-60Hz Total power 12W Integral electronic power supply
525032	NATURAL WHITE MID-POWER LEDs 8,8W/220-240V/50-60Hz Total power 11W Integral electronic power supply
525033	WARM WHITE MID-POWER LEDs 8,8W/220-240V/50-60Hz Total power 11W Integral electronic power supply

PERSEO 16

525092	NATURAL WHITE POWER LEDs 17,6W/220-240V/50-60Hz Total power 20W Integral electronic power supply
525093	WARM WHITE POWER LEDs 17,6W/220-240V/50-60Hz Total power 20W Integral electronic power supply
525082	NATURAL WHITE POWER LEDs 17,6W/220-240V/50-60Hz Total power 20W Integral electronic power supply
525083	WARM WHITE POWER LEDs 17,6W/220-240V/50-60Hz Total power 20W Integral electronic power supply
525062	NATURAL WHITE POWER LEDs 17,6W/220-240V/50-60Hz Total power 20W Integral electronic power supply
525063	WARM WHITE POWER LEDs 17,6W/220-240V/50-60Hz Total power 20W Integral electronic power supply
525072	NATURAL WHITE POWER LEDs 17,6W/220-240V/50-60Hz Total power 20W Integral electronic power supply
525073	WARM WHITE POWER LEDs 17,6W/220-240V/50-60Hz Total power 20W Integral electronic power supply

PERSEO 30

525132	NATURAL WHITE POWER LEDs 48W/220-240V/50-60Hz Total power 53W Integral electronic power supply
525133	WARM WHITE POWER LEDs 48W/220-240V/50-60Hz Total power 53W Integral electronic power supply
525122	NATURAL WHITE POWER LEDs 48W/220-240V/50-60Hz Total power 53W Integral electronic power supply
525123	WARM WHITE POWER LEDs 48W/220-240V/50-60Hz Total power 53W Integral electronic power supply
525102	NATURAL WHITE POWER LEDs 48W/220-240V/50-60Hz Total power 53W Integral electronic power supply
525103	WARM WHITE POWER LEDs 48W/220-240V/50-60Hz Total power 53W Integral electronic power supply
525112	NATURAL WHITE POWER LEDs 48W/220-240V/50-60Hz Total power 53W Integral electronic power supply
525113	WARM WHITE POWER LEDs 48W/220-240V/50-60Hz Total power 53W Integral electronic power supply

ITA. La sicurezza dell'apparecchio è garantita solo rispettando le normative europee del settore elettrico e le istruzioni contenute in questa scatola: pertanto è necessario conservarle. Il rispetto di queste istruzioni è fondamentale per il corretto funzionamento dell'apparecchio e dell'impianto.

UK. For safety to be assured, the fitting has to be installed and used properly, in compliance with EU Regulations and Directives on electrical and electronic equipments and with the mounting instructions included in the present box: please keep this instruction data sheet for future reference.

ESP. La seguridad del aparato se garantiza únicamente respetando las normativas europeas del sector eléctrico y las instrucciones contenidas en esta caja, por lo tanto es necesario conservarlas. La observación de estas instrucciones es fundamental par el correcto funcionamiento del aparato y de la instalación.

FR. La sécurité de l'appareil ne peut être assurée que par un strict respect des Normatives Européennes sur les équipements électriques et des instructions suivantes. Gardez ces instructions pour des consultations ultérieures.

DE. Die Leuchtensicherheit ist nur gewährleistet, wenn die europäischen Normen des Elektroniksektors und die hier beigelegte Montageanleitung befolgt werden. Aus diesem Grund sollte sie aufbewahrt werden. Die Beachtung der Anleitung ist Voraussetzung für die einwandfreie Funktion der Leuchte und der Installation.

RU. Для соблюдения мер безопасности убедитесь, что прибор будет установлен и использоваться согласно настоящей инструкции в соответствии с нормами и правилами ЕС по электричеству и электрооборудованию. Пожалуйста, сохраните инструкцию для будущих обращений.

ITA. -Stagno alla polvere e protetto contro i getti d'acqua IP65
-Idoneo per montaggio su superfici normalmente infiammabili ∇
-Apparecchio di classe I, ⊕
-Marcatura CE

UK. -Dust-tight and protected against waterjets IP65
- Suitable for installation on normally flammable surfaces ∇
-Class I, ⊕ lighth fixture
-CE Marking

ESP. -Protección contra el polvo y salpicaduras de agua IP65
-Idóneo para instalación en superficies normalmente inflamables ∇
-Luminaria de clase I, ⊕
-Marcado CE

FR. -Etanche aux poussières et protégé contre les jets d'eau IP65
-Peut être installé sur surfaces normalement inflammables ∇
-Appareil de classe I, ⊕
-Marquage CE

DE. -Staubdicht. Schutz gegen Strahlwasser aus allen Richtungen IP65
- Die Leuchte kann auf normal brennbaren Oberflächen installiert werden ∇
- Schutzklasse I, ⊕
- Kennzeichnung CE

RU. -пыленепроницаем и защищен от капель IP65
-подходит для установки на воспламеняющихся поверхностях ∇
-светильник Class I, ⊕
-Маркировка CE

FISSAGGIO - INSTALLATION

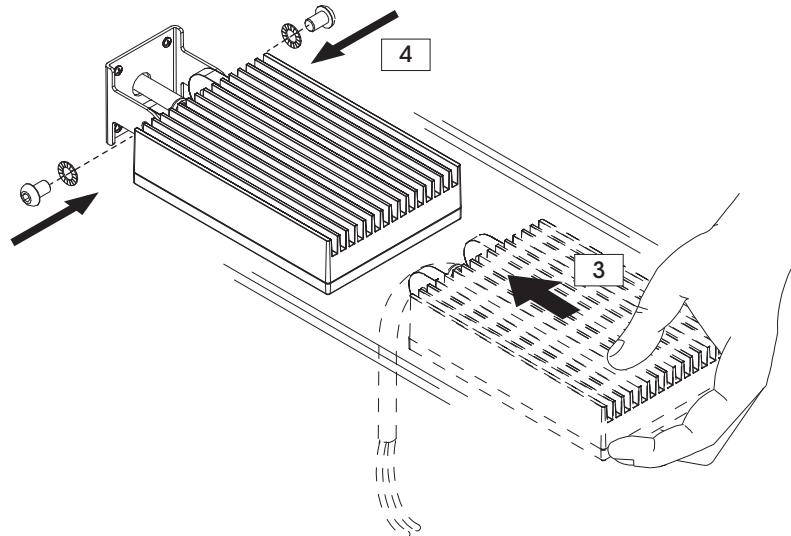
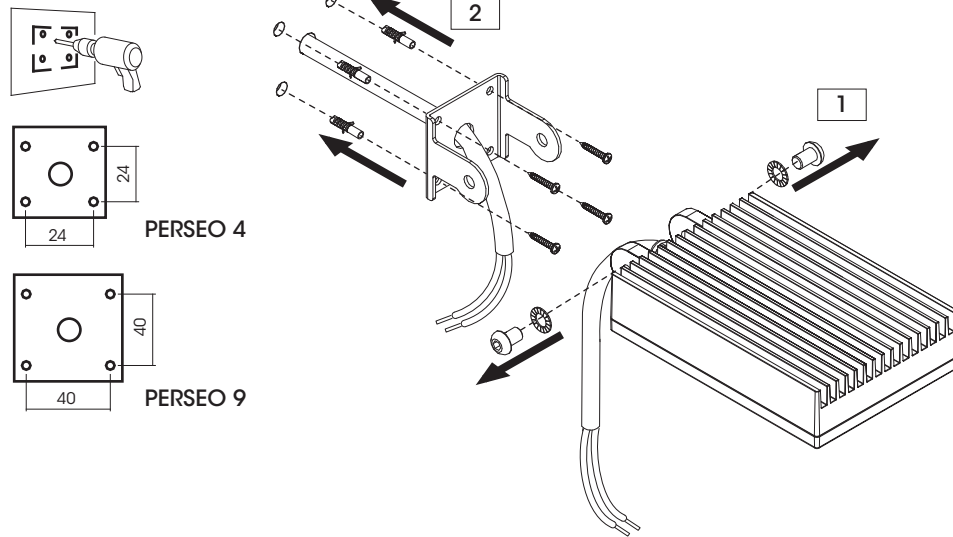

CABLAGGIO - WIRING

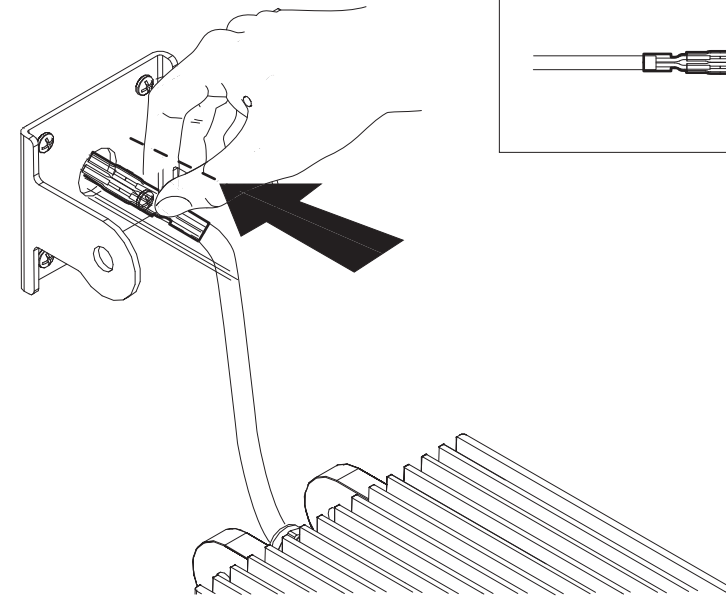
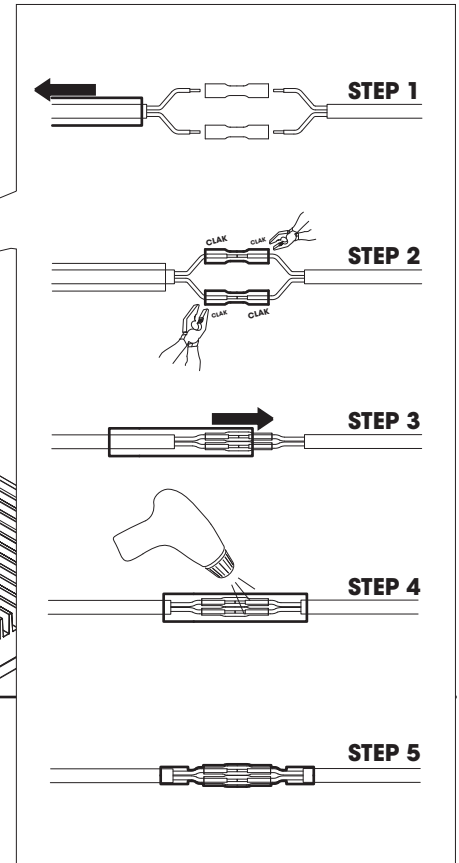
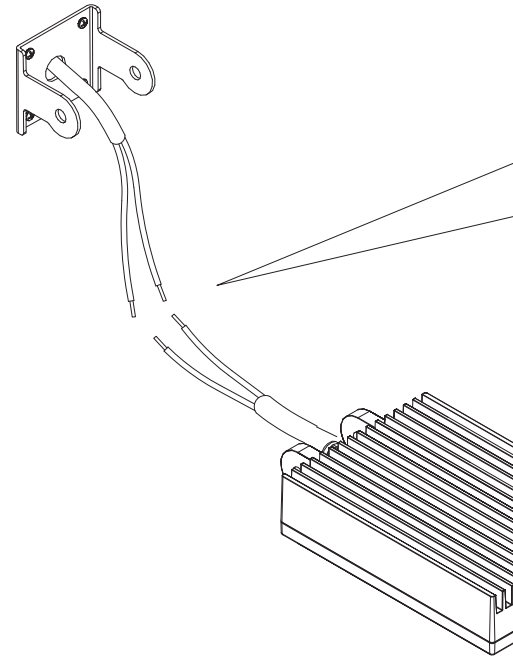

FISSAGGIO - INSTALLATION: PERSEO 16

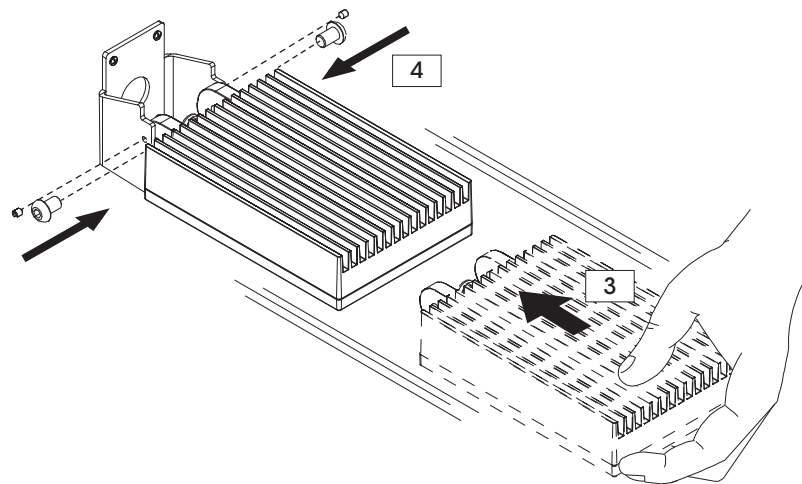
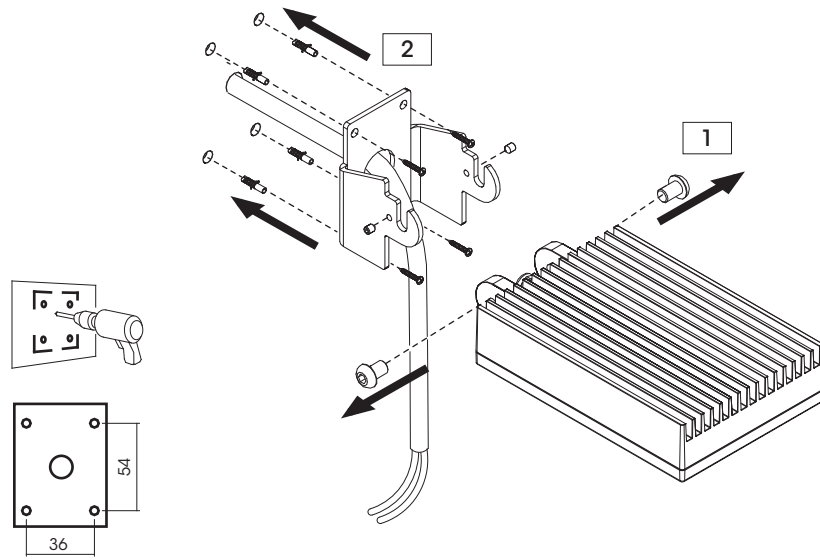

FISSAGGIO - INSTALLATION: PERSEO 30

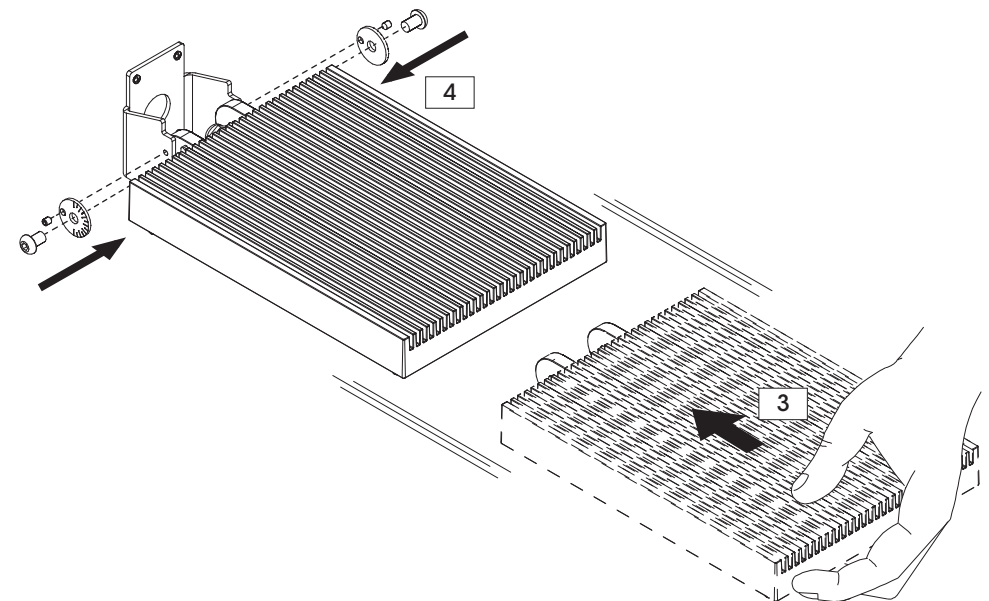
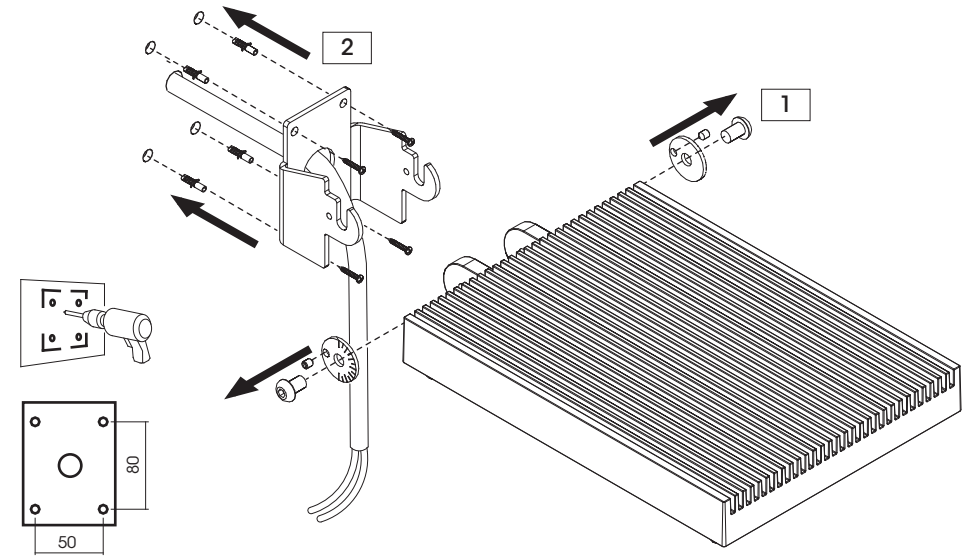

INCLINAZIONE CORPO LAMPADA - LUMINAIRE ADJUSTMENT: PERSEO 30

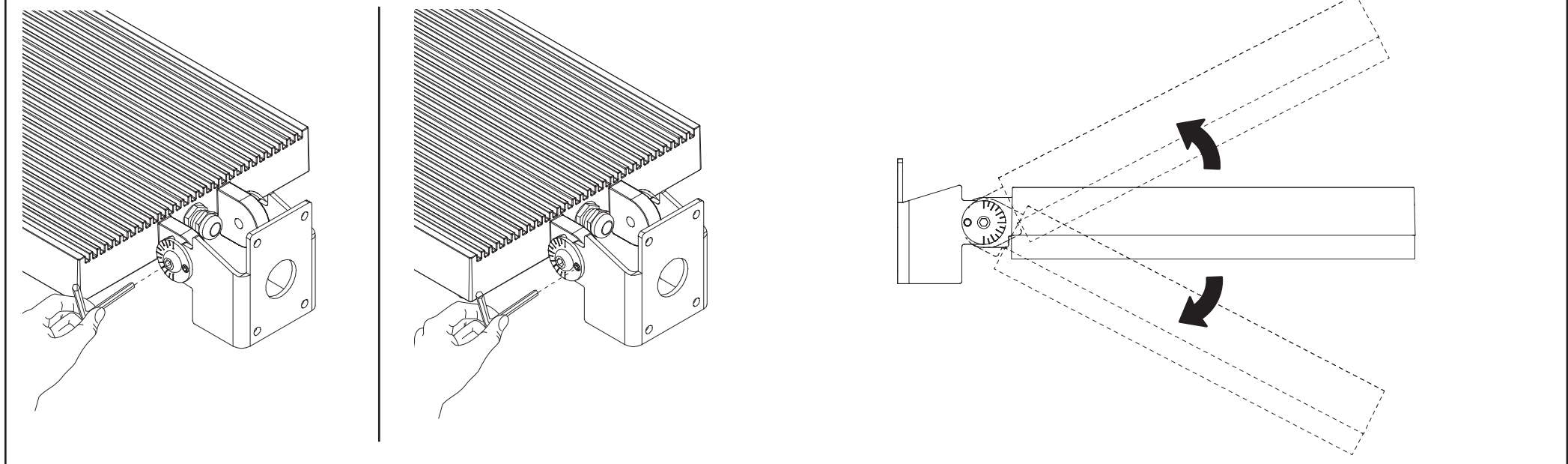

CABLAGGIO - WIRING - PERSEO 16 / PERSEO 30

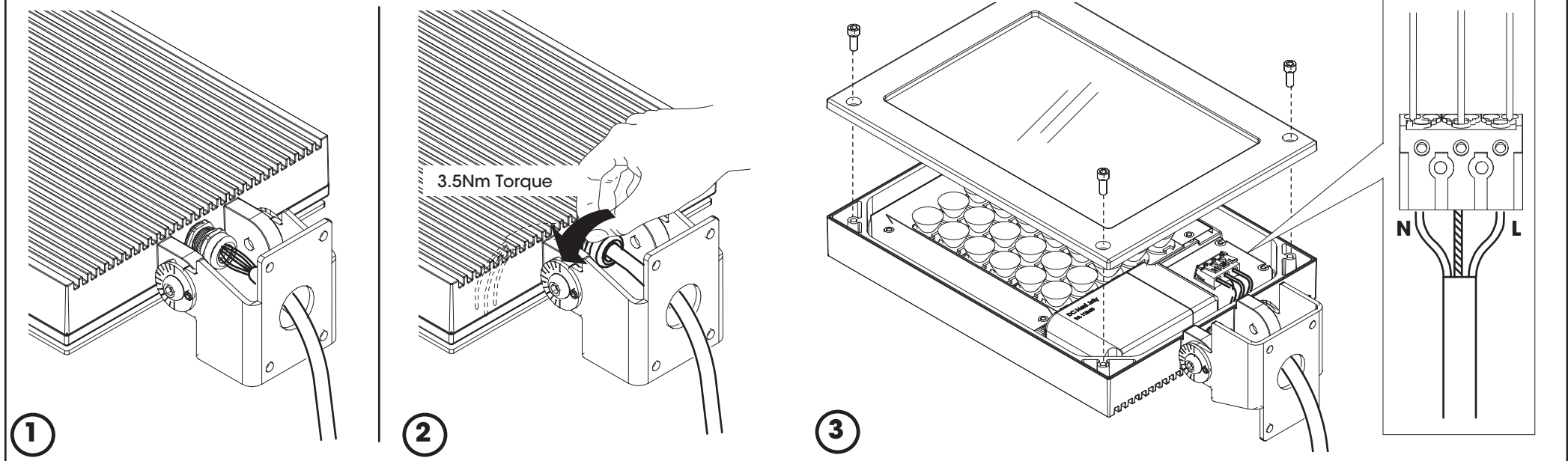

FISSAGGIO - INSTALLATION cod.157/158 - cod.161/162

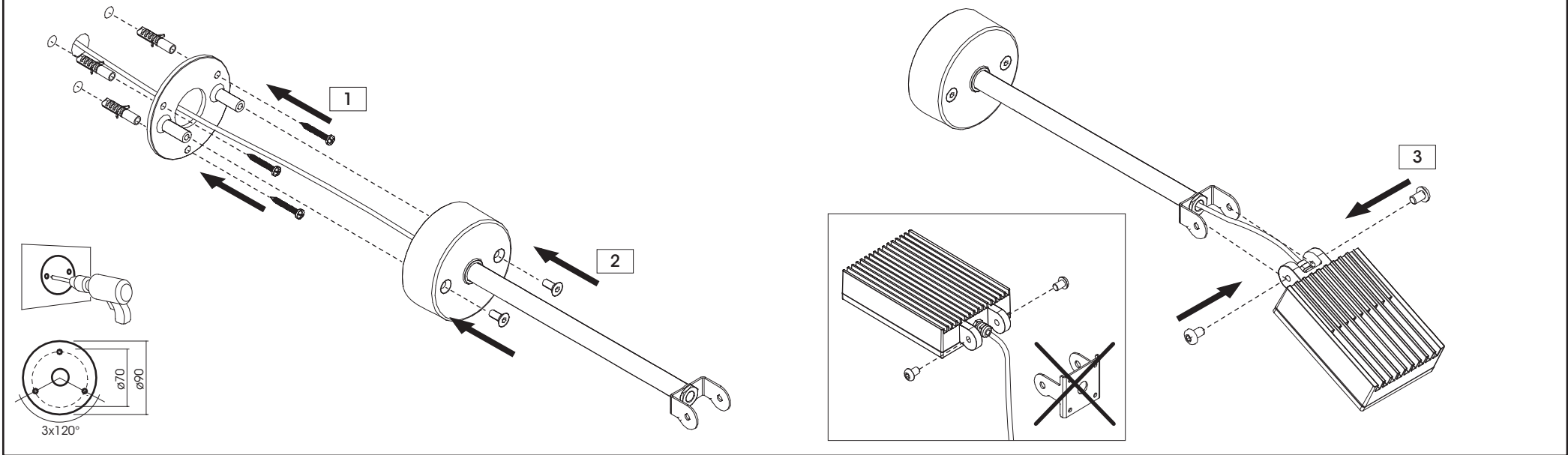

CABLAGGIO - WIRING cod.157/158 - cod.161/162

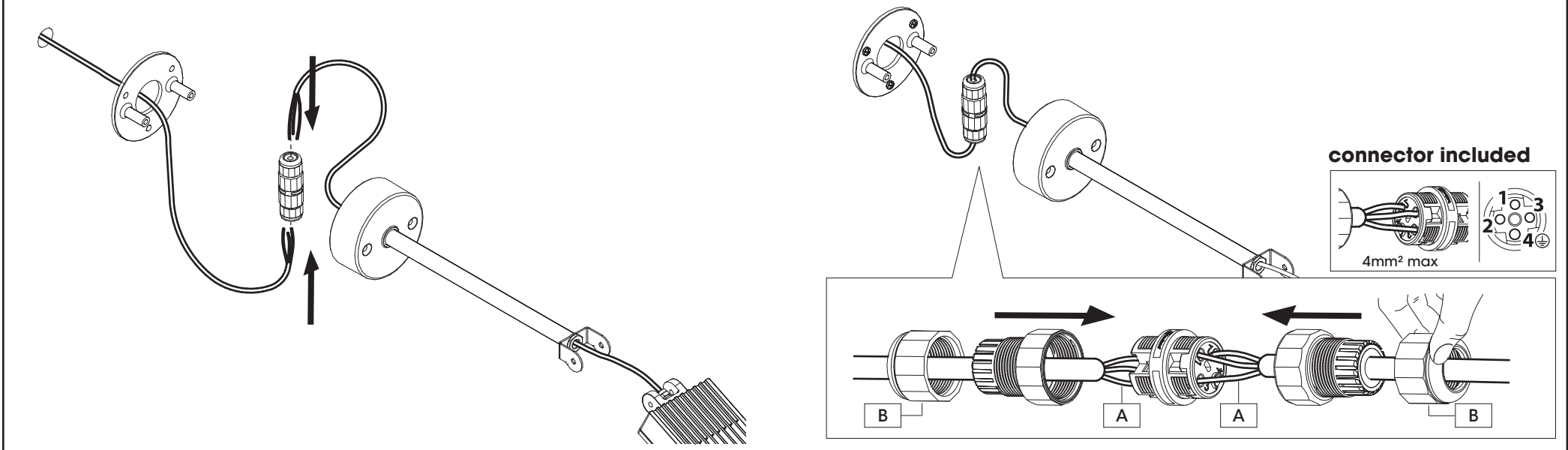

FISSAGGIO - INSTALLATION
cod.88

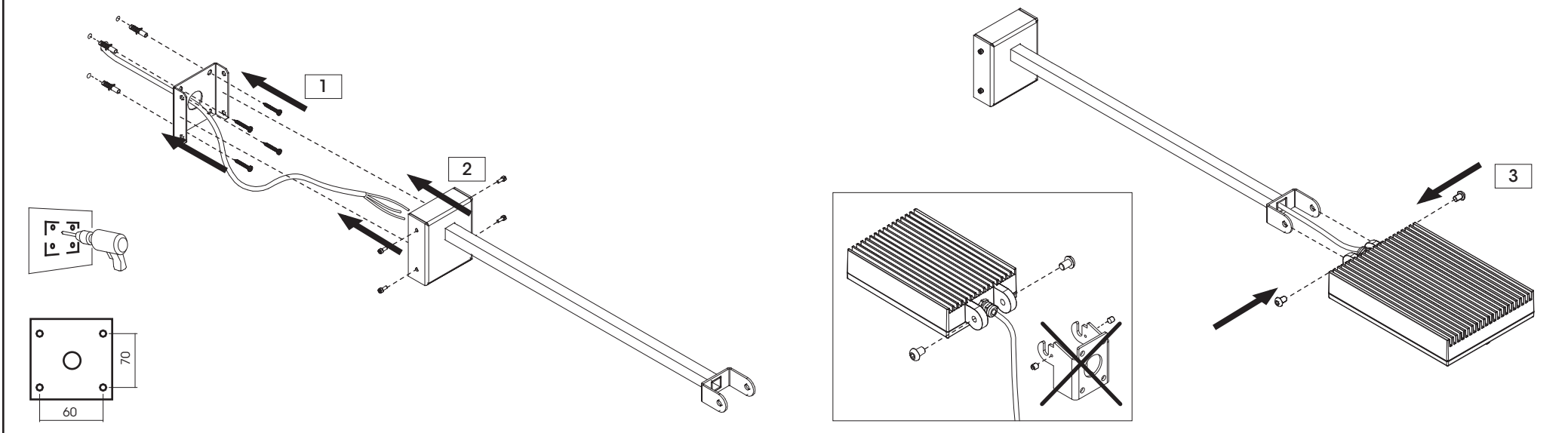

CABLAGGIO - WIRING
cod.88

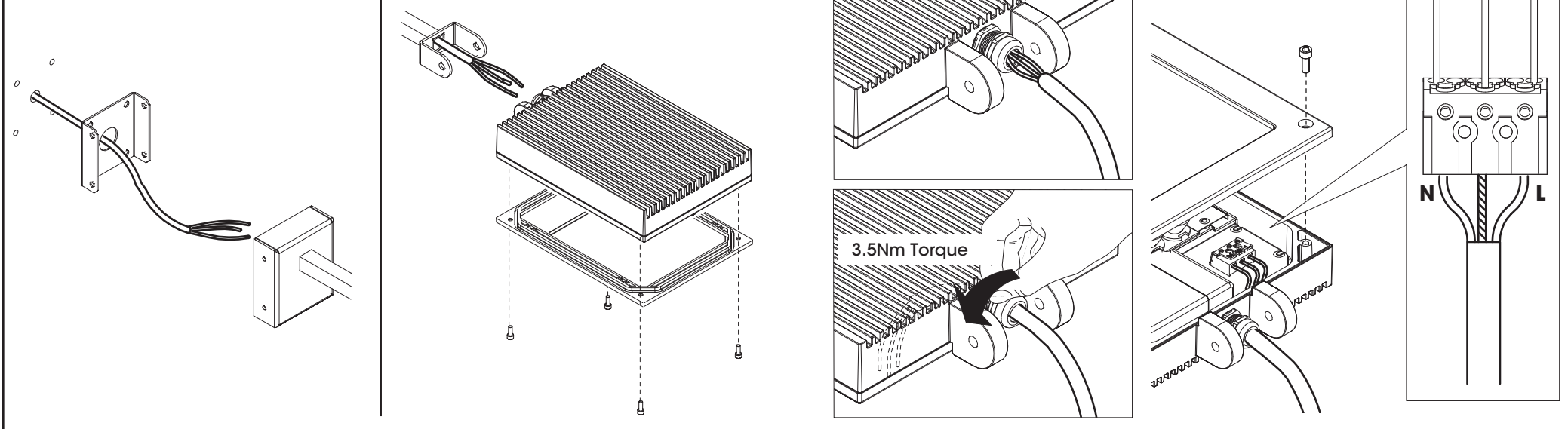

FISSAGGIO - INSTALLATION
cod.181

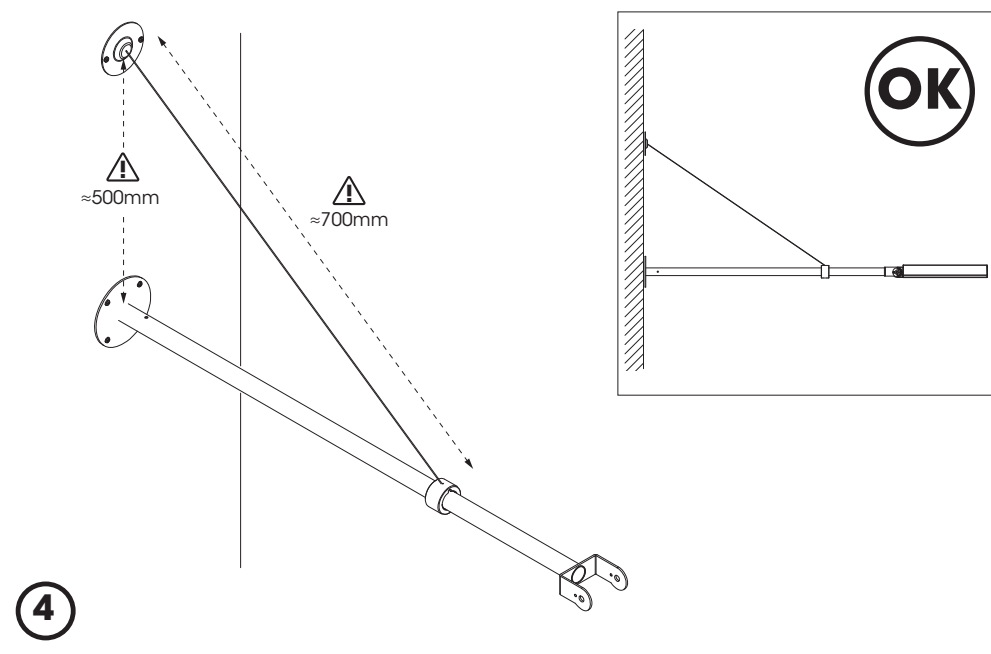
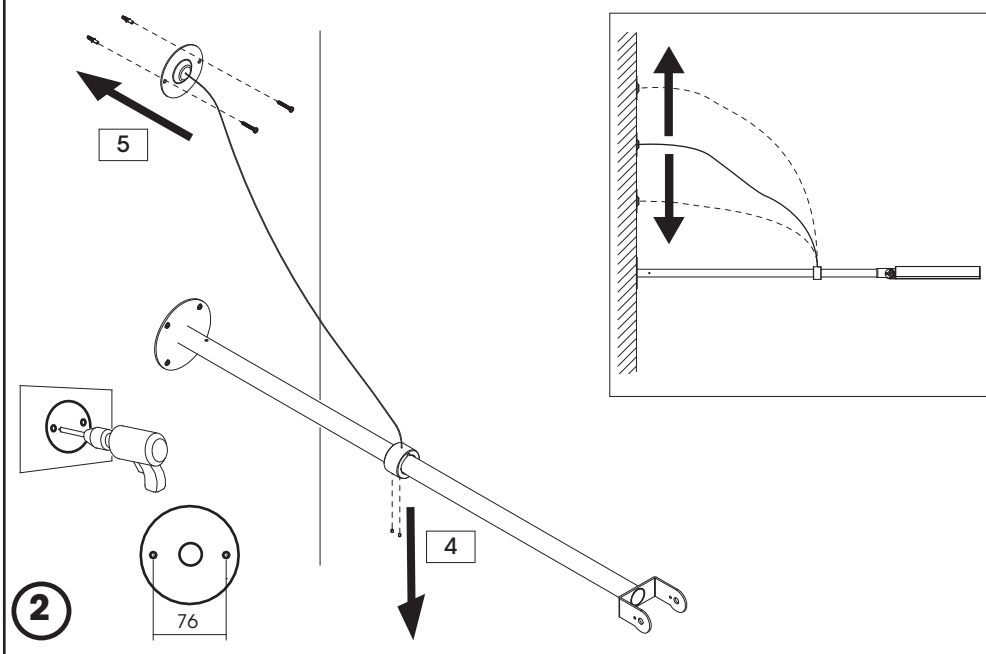
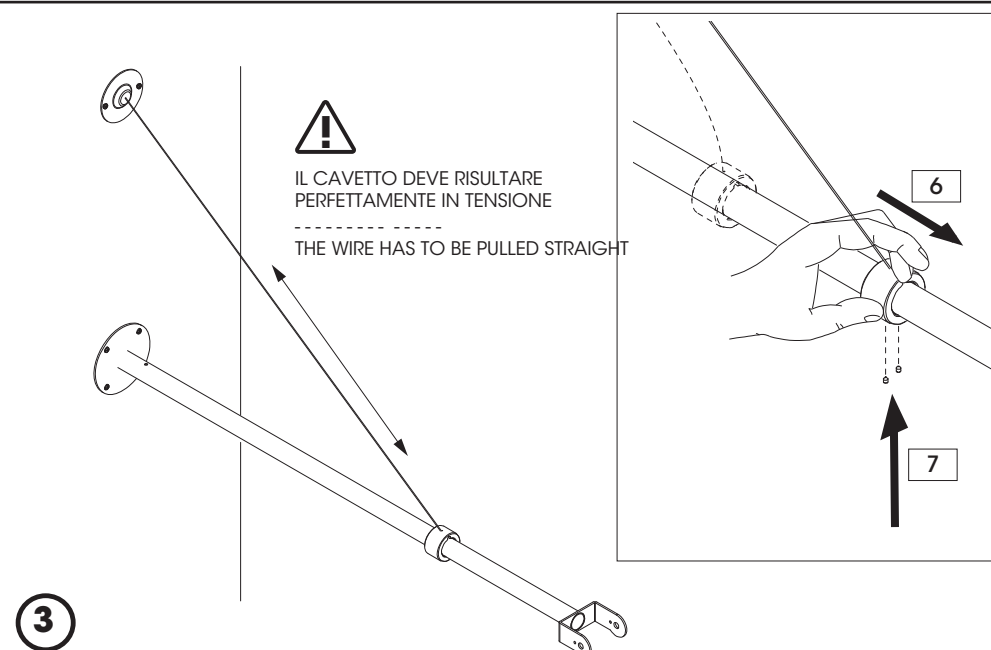
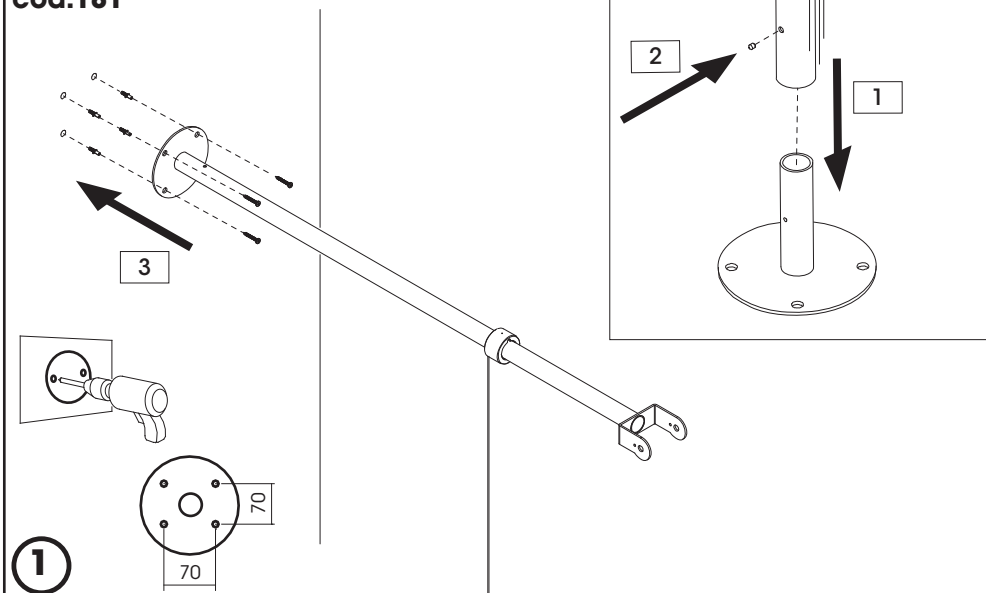

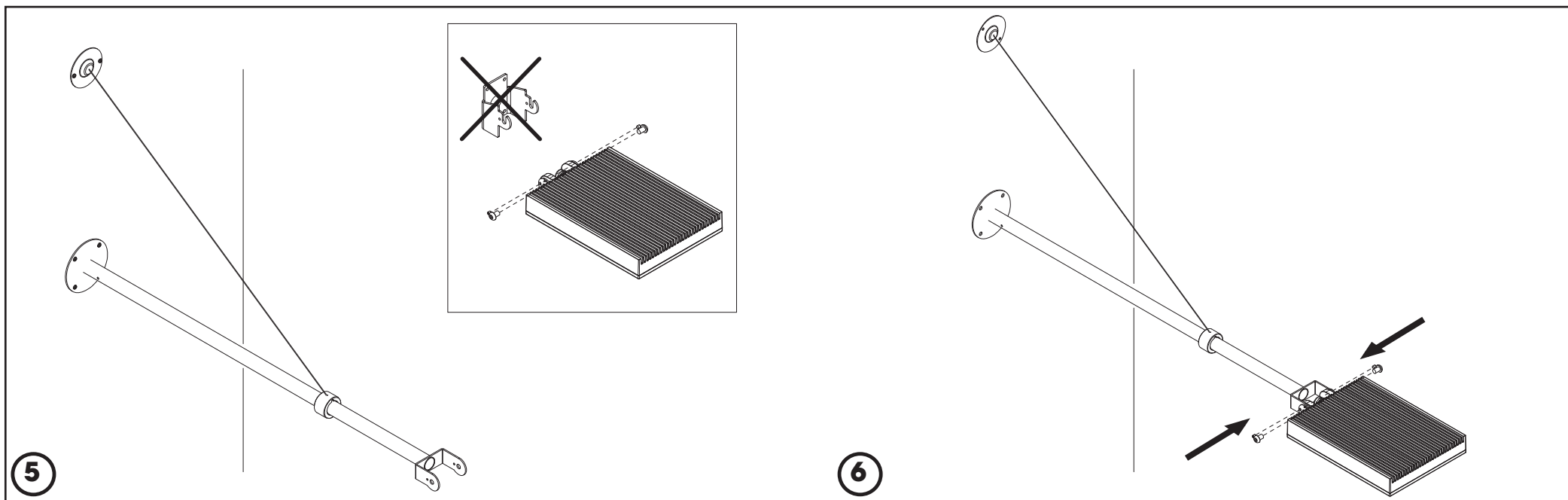

CABLAGGIO - WIRING
cod.181

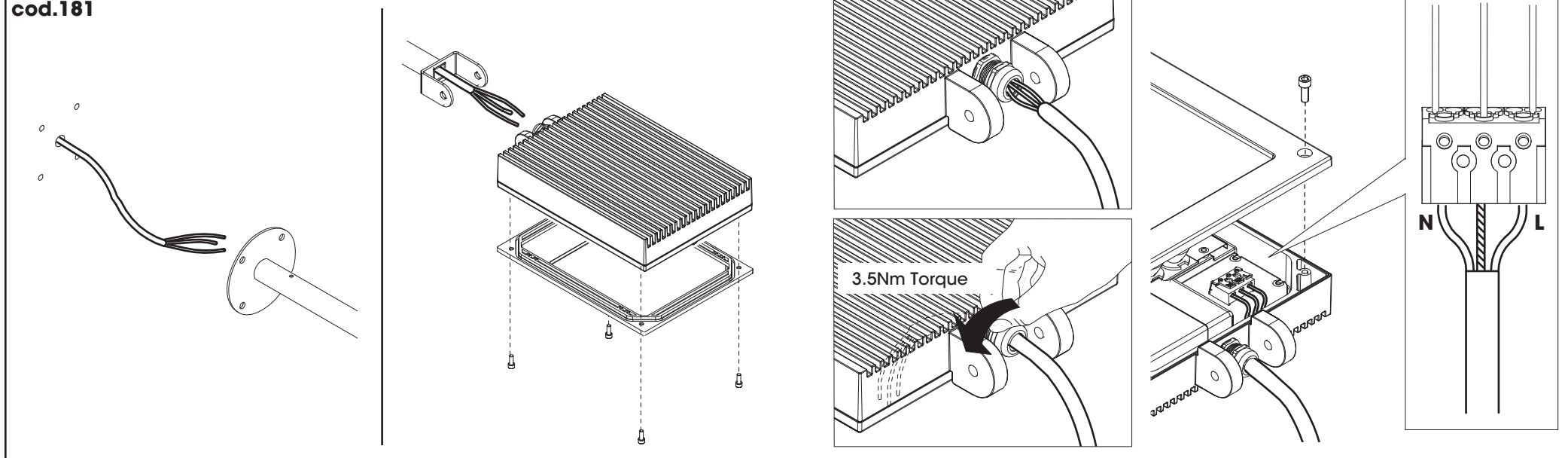

FISSAGGIO - INSTALLATION
cod.177/178

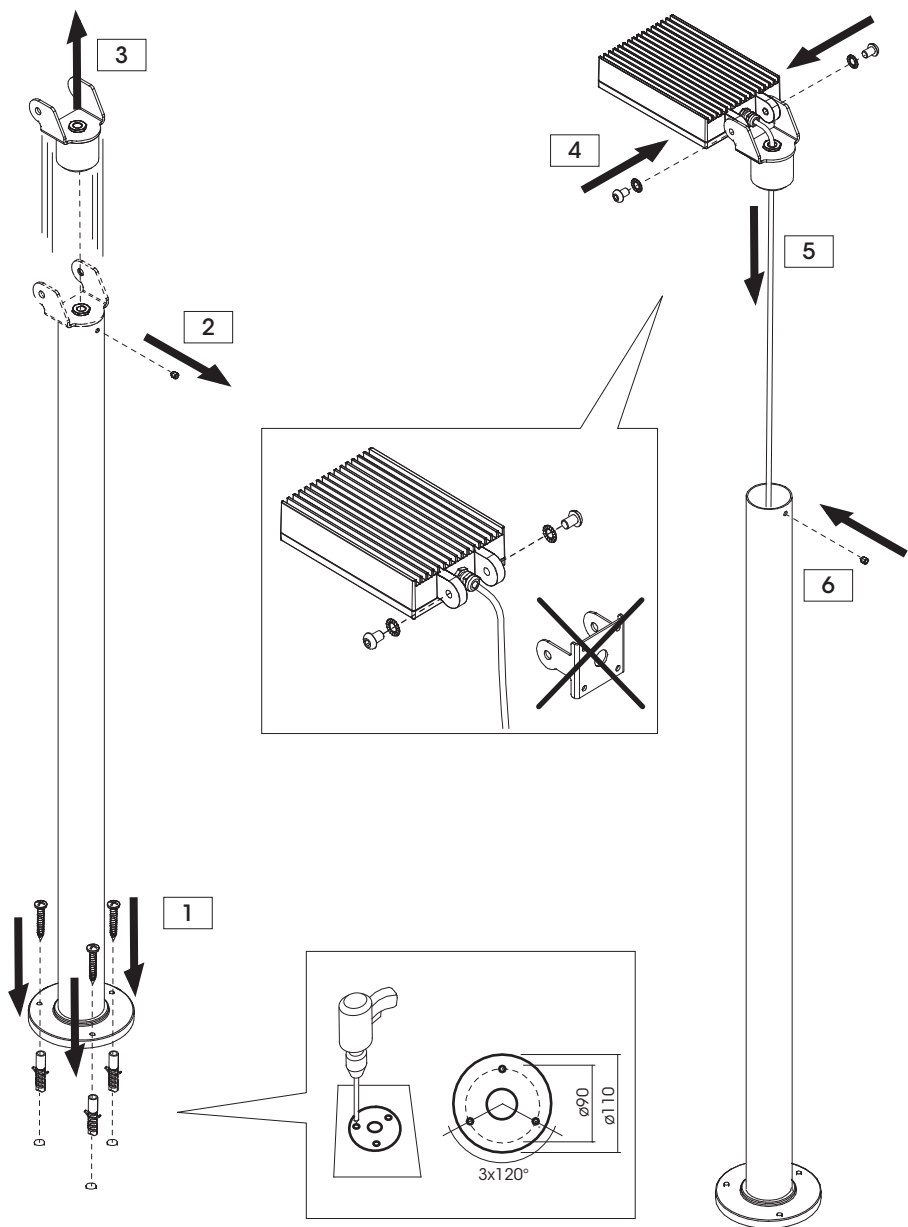

CABLAGGIO - WIRING
cod.177/178

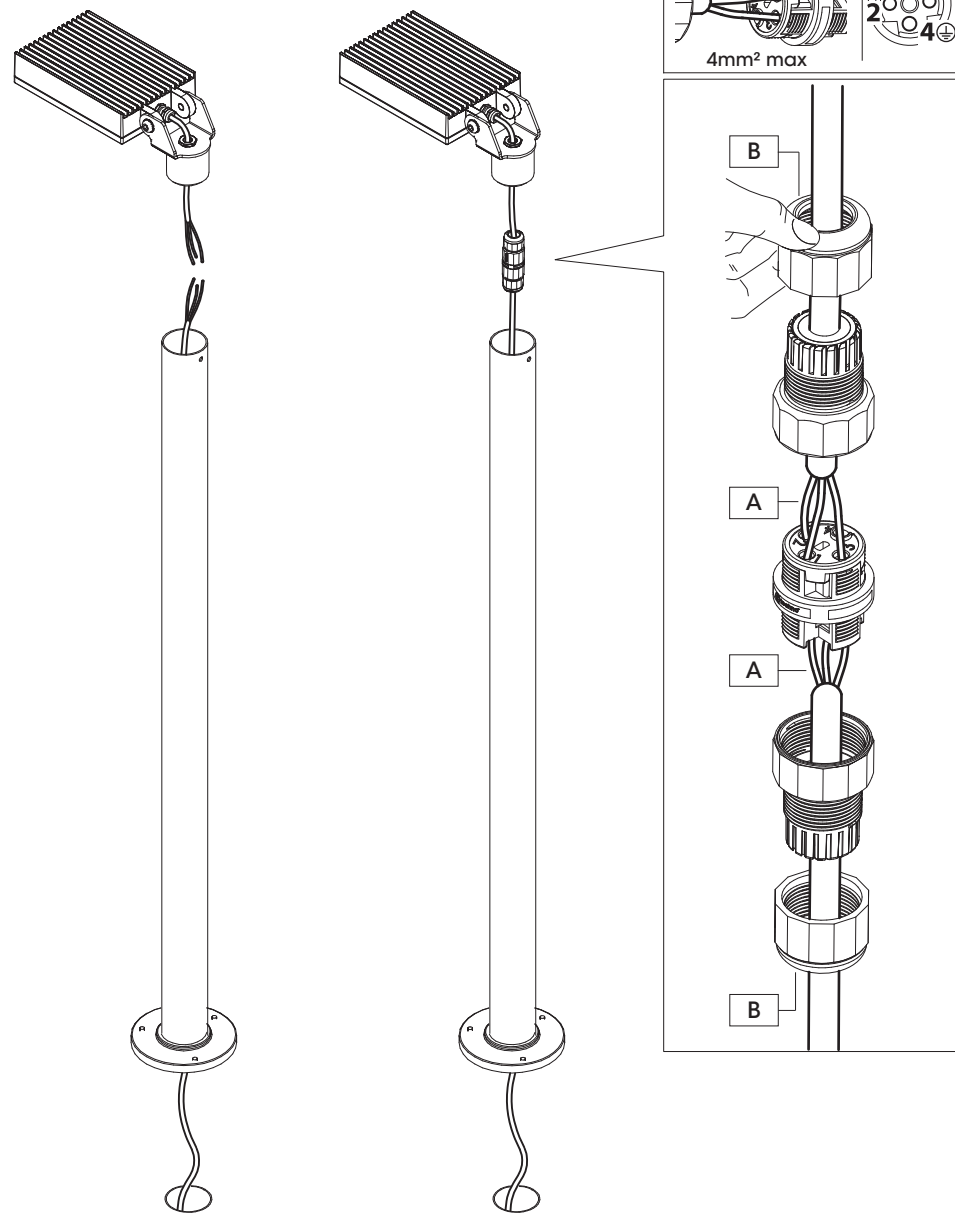

FISSAGGIO PALO CON BASE - INSTALLATION: POLE WITH BASE
cod.179

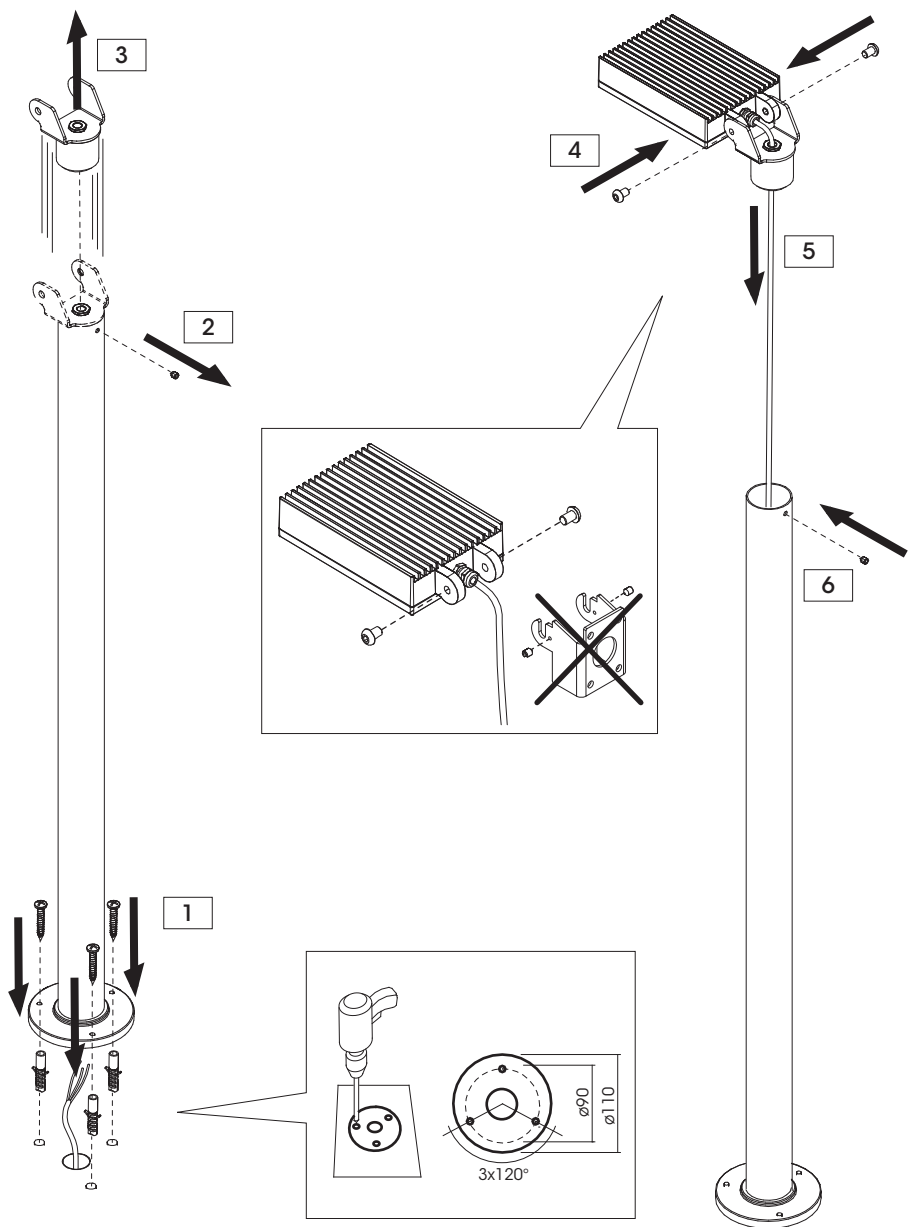

CABLAGGIO PALO CON BASE - WIRING: POLE WITH BASE
cod.179

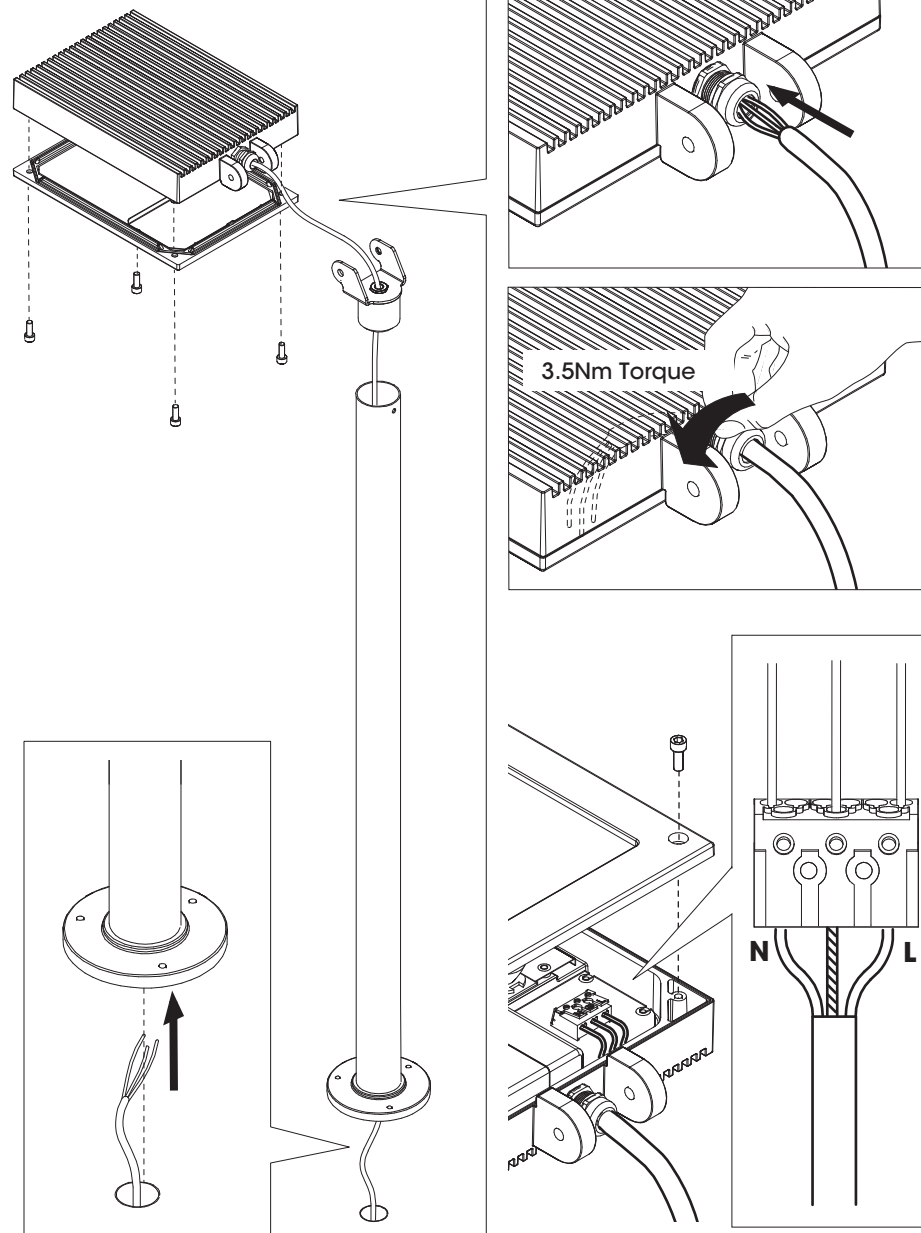

FISSAGGIO PALO INTERRATO - INSTALLATION: POLE IN-GROUND
cod.180

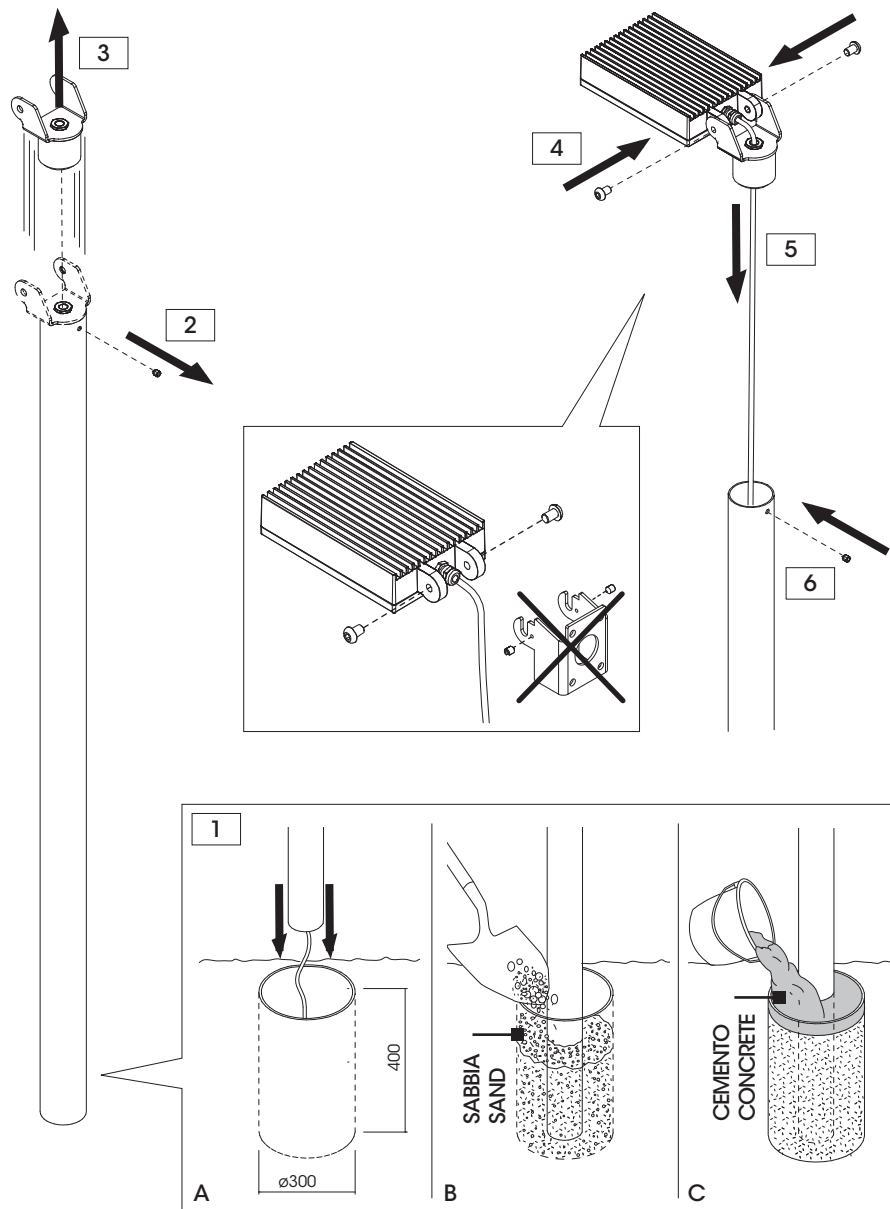

CABLAGGIO PALO INTERRATO - WIRING: POLE IN-GROUND
cod.180

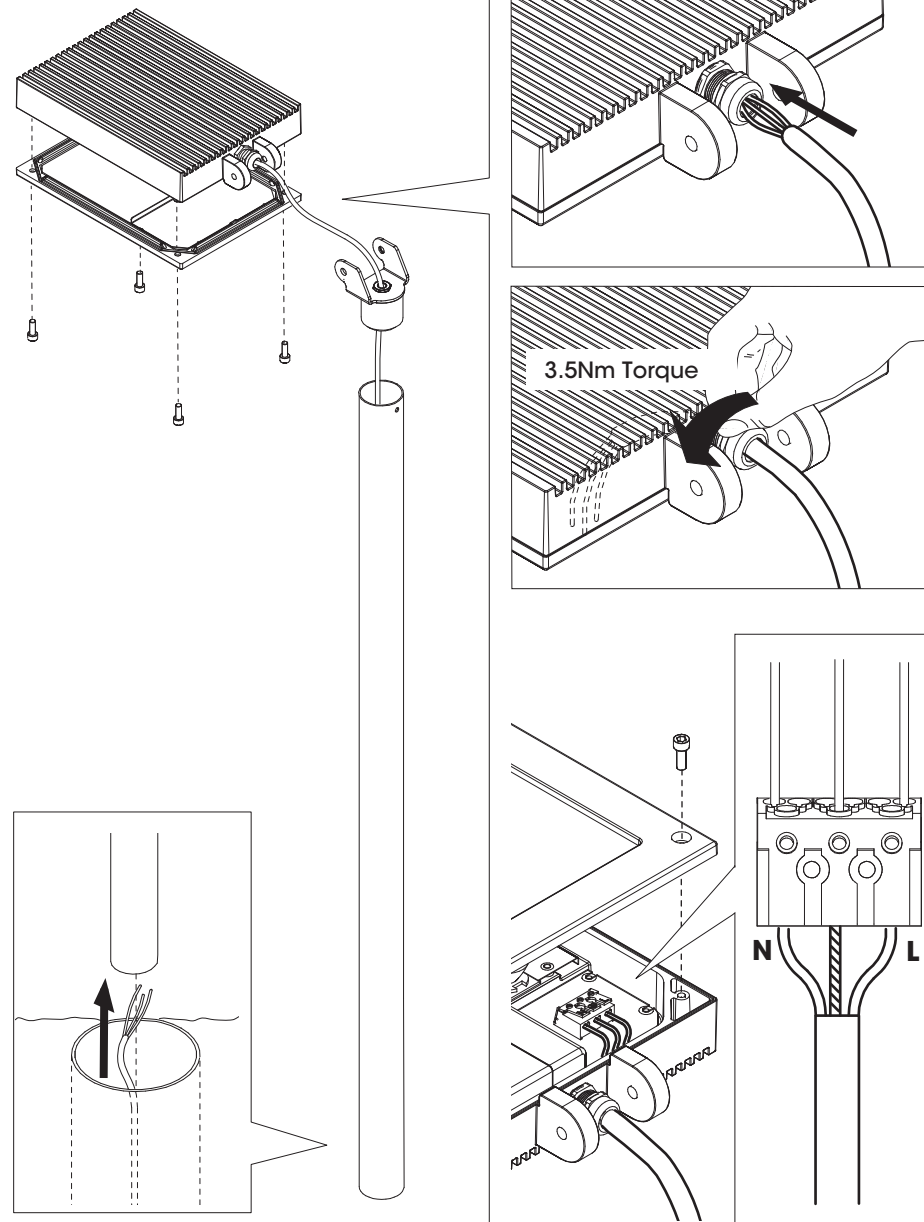

PALO CON BASE - POLE WITH BASE
cod.248/249/4140/4150

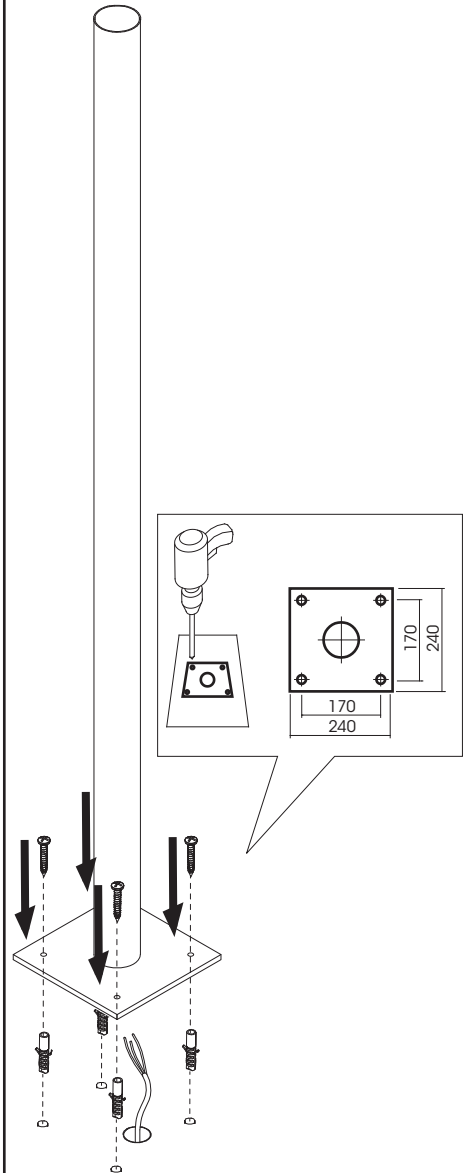

PALO INTERRATO - POLE IN-GROUND
cod.250/251/4145/4155

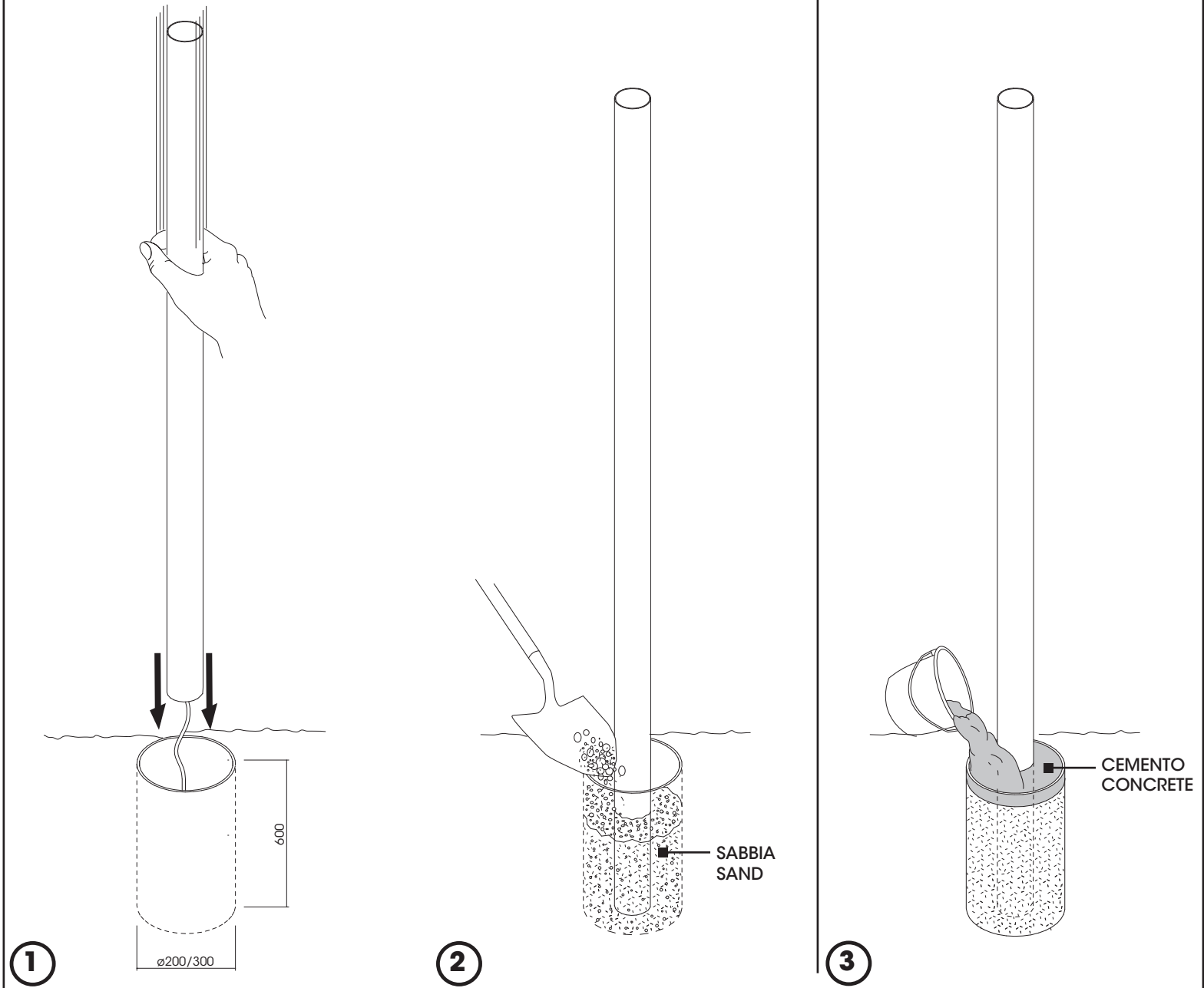

FISSAGGIO BRACCIO SU PALO cod.248/249/250/251/140/4150/4145/4155
INSTALLATION: BRACKET ON POLE cod.248/249/250/251/4140/4150/4145/4155

cod.223-227-231

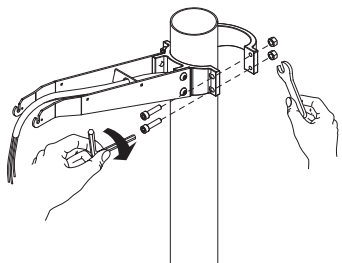

cod.221-225-229

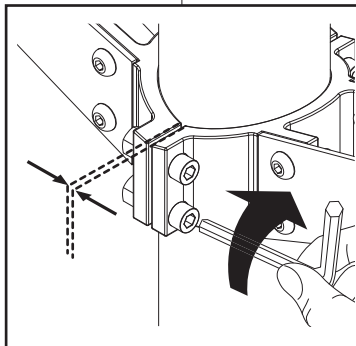
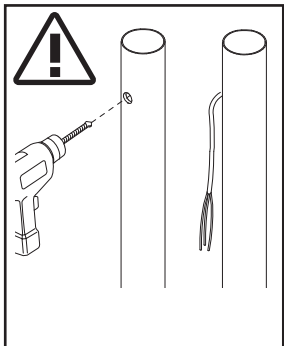
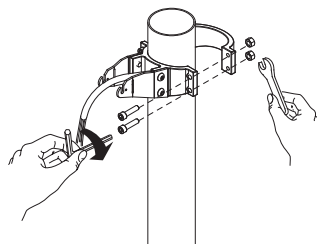

LO SPAZIO RISULTANTE TRA LE GANASCE E' DA CONSIDERASI NORMALE. NON FORZARE A FONDO LA CHIUSURA DELLE VITI.
A MINIMUM DISTANCE BETWEEN THE TWO ELEMENTS IS CORRECT. DO NOT TIGHTEN SCREWS EXCESSIVELY

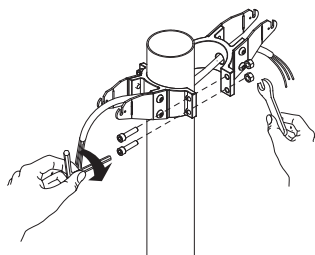
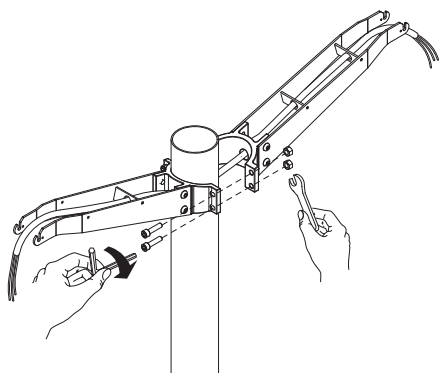

cod.224-228-232

cod.222-226-230

INSTALLAZIONE CORPO LAMPADA SU BRACCI PERSEO16
INSTALLATION: LUMINAIRE ON BRACKET

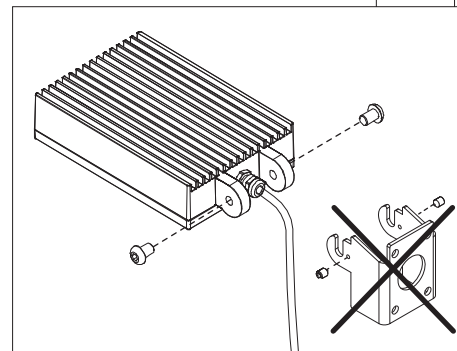
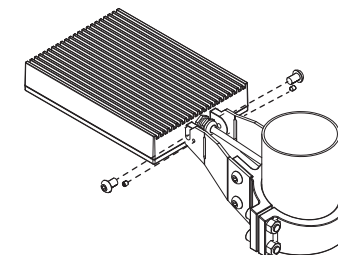
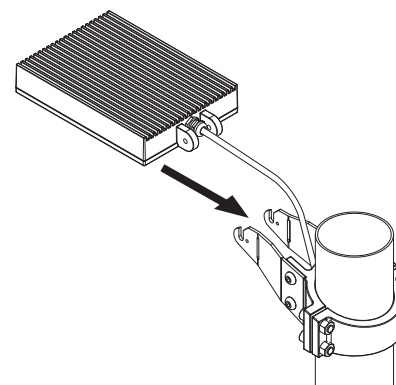

CABLAGGIO SU PALO INTERRATO - WIRING ON POLE IN-GROUND
 cod.250/251/4145/4155

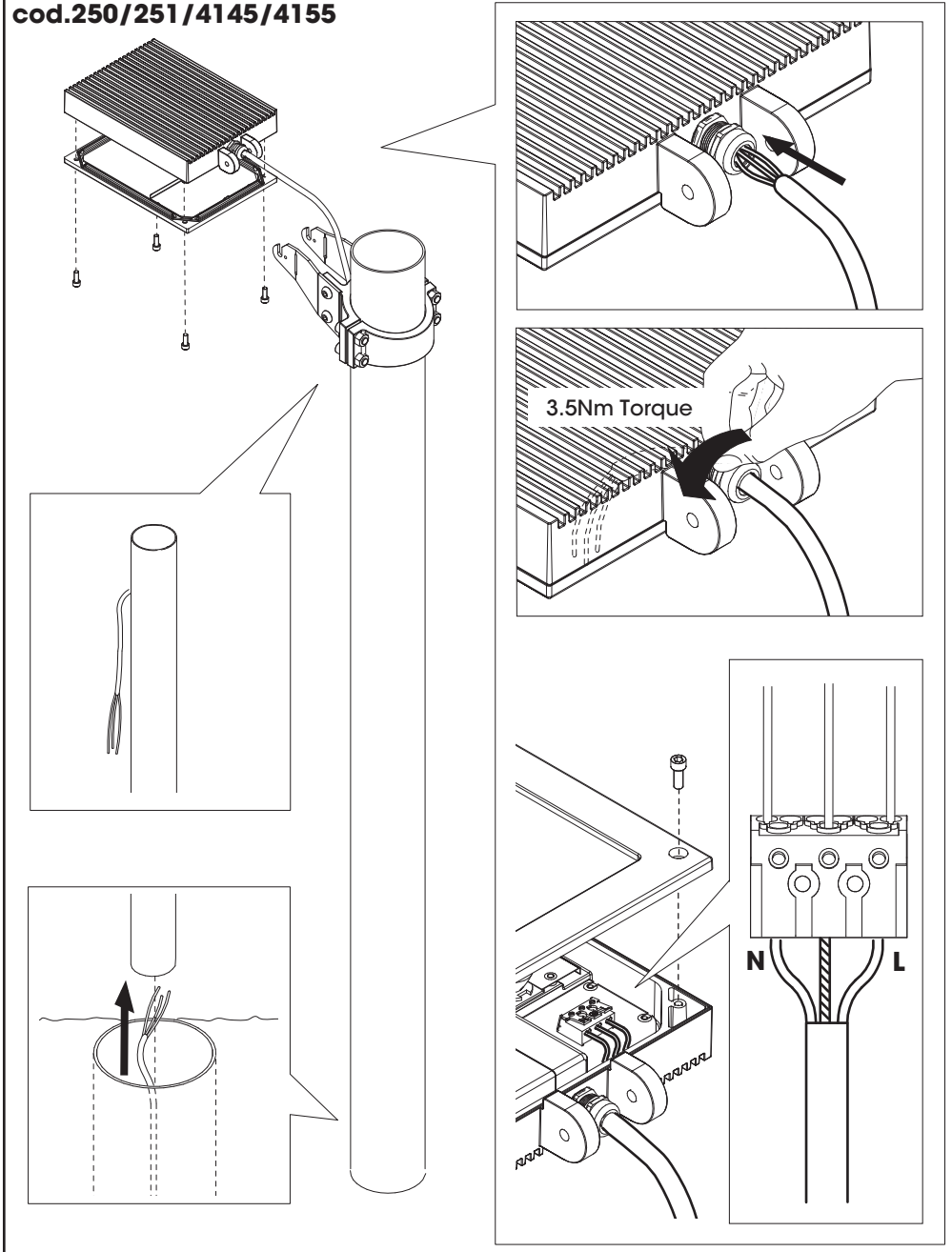

CABLAGGIO PALO CON BASE - WIRING POLE WITH BASE
 cod.248/249/4140/4150

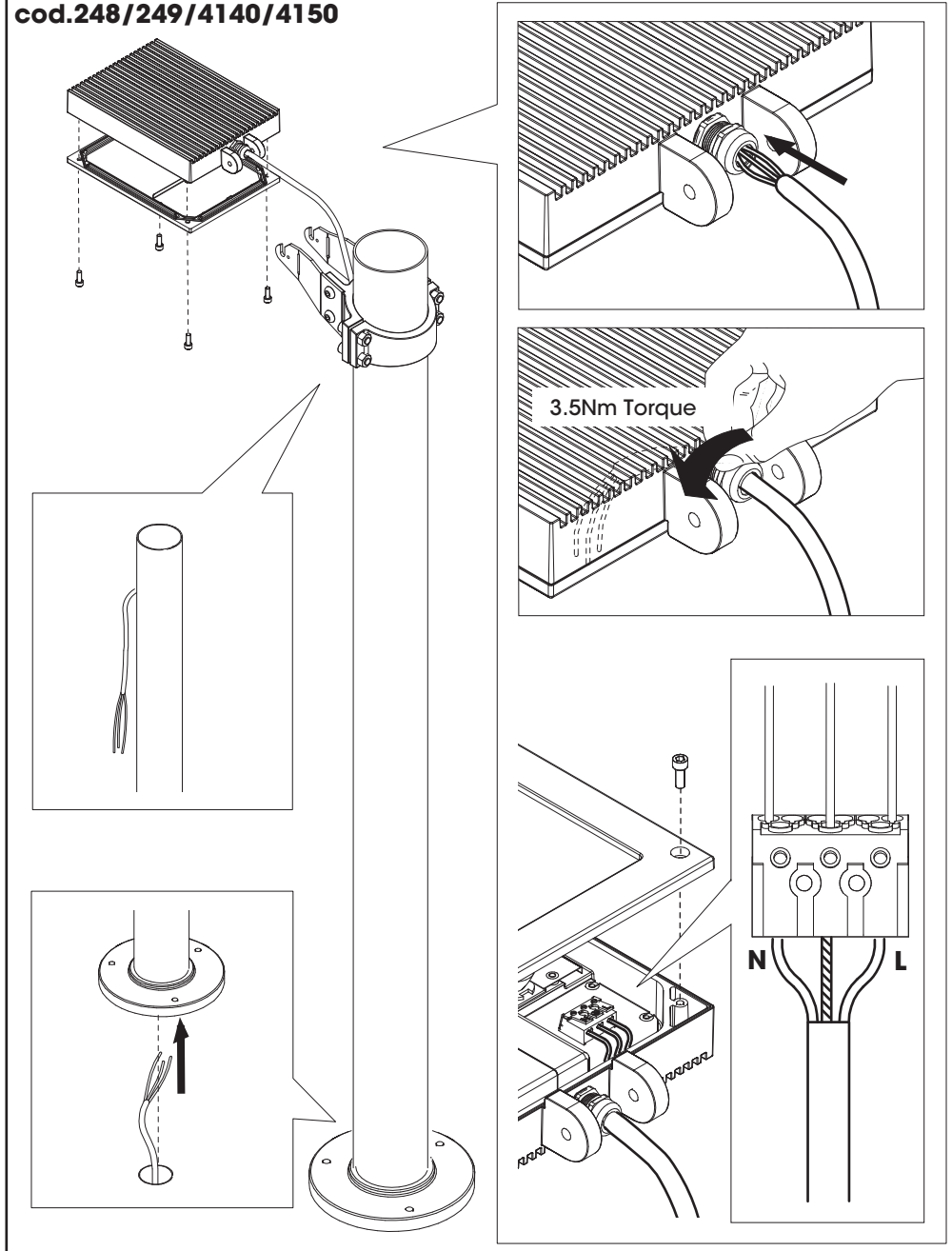

FISSAGGIO BRACCIO SU PALO cod.248/249/250/251/4140/4145/4150/4155
INSTALLATION: BRACKET ON POLE cod.248/249/250/251/4140/4145/4150/4155

cod.79-94-113

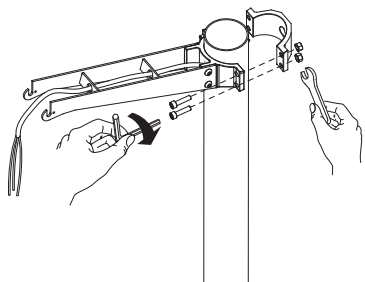

cod.78-93-112

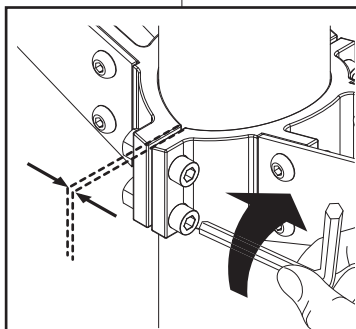
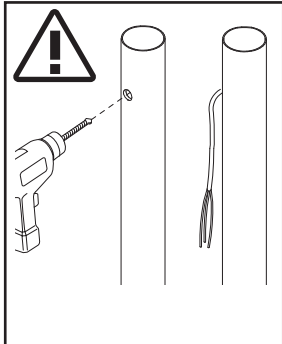
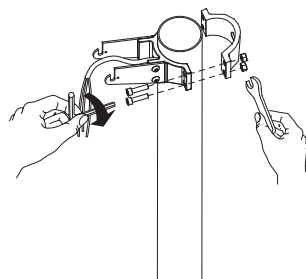

LO SPAZIO RISULTANTE TRA LE GANASCE E' DA CONSIDERASI NORMALE. NON FORZARE A FONDO LA CHIUSURA DELLE VITI.
 A MINIMUM DISTANCE BETWEEN THE TWO ELEMENTS IS CORRECT. **DO NOT TIGHTEN SCREWS EXCESSIVELY**

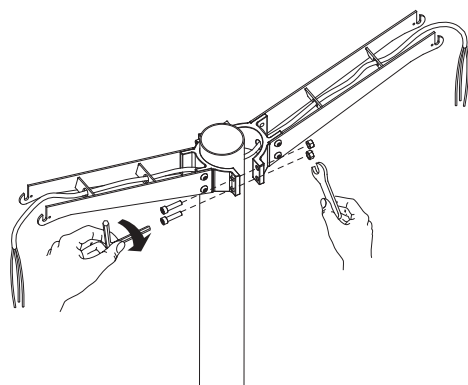

cod.89-96-115

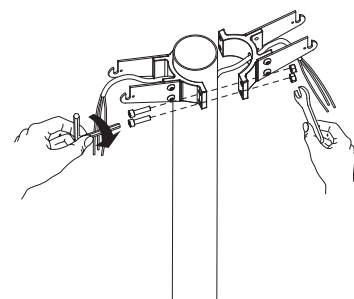

cod.90-95-114

INSTALLAZIONE CORPO LAMPADA SU BRACCI PERSEO 30
INSTALLATION: LUMINAIRE ON BRACKET

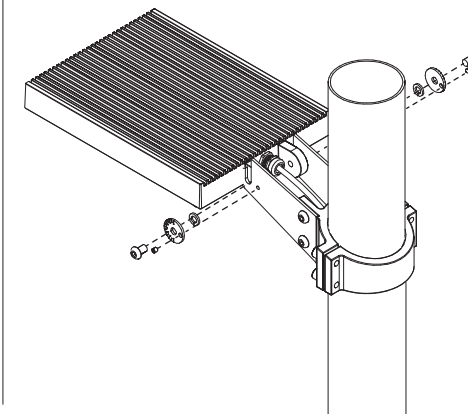
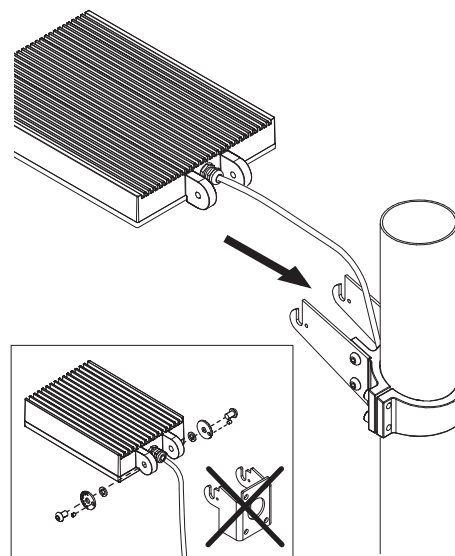

INCLINAZIONE CORPO LAMPADA - LUMINAIRE ADJUSTMENT

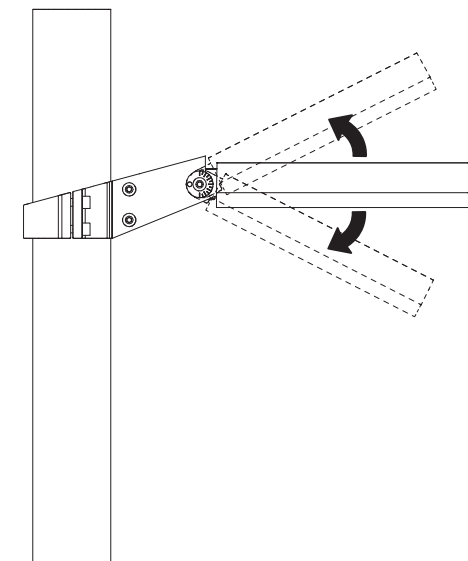
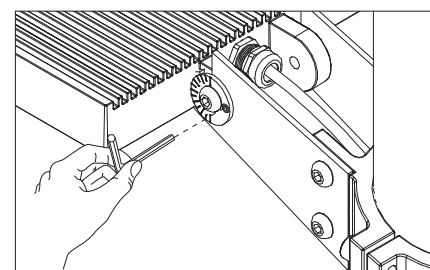
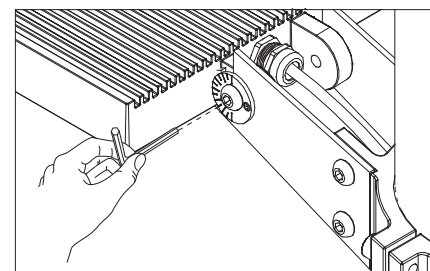

CABLAGGIO SU PALO INTERRATO - WIRING ON POLE IN-GROUND
 cod.250/251/4145/4155

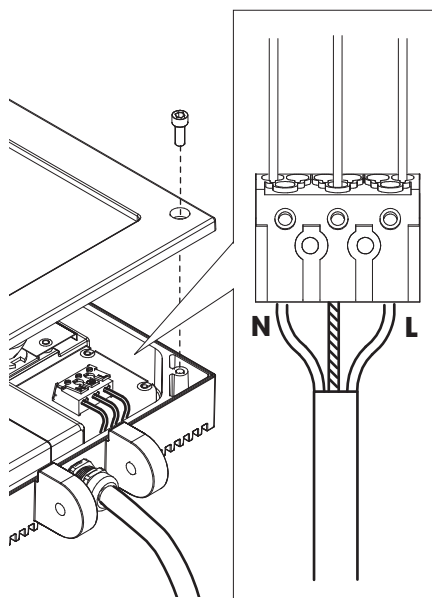
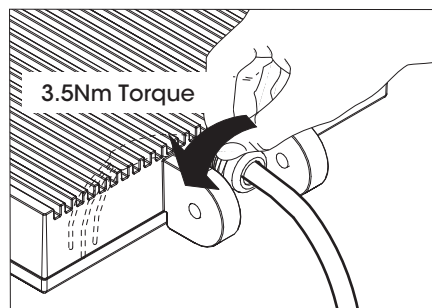
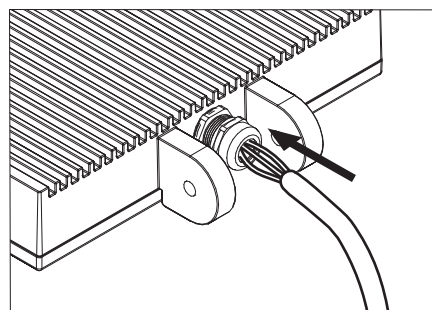
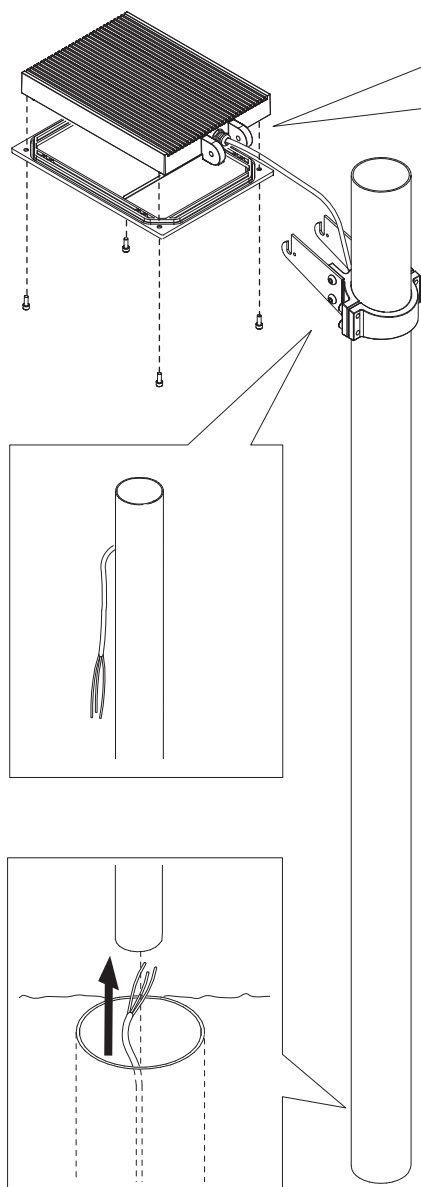

CABLAGGIO PALO CON BASE - WIRING POLE WITH BASE
 cod.248/249/4140/4150

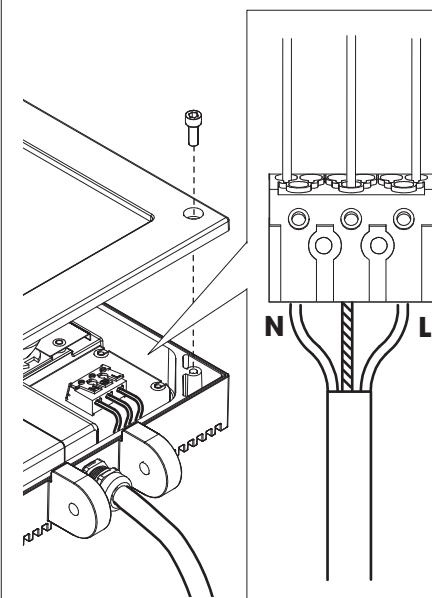
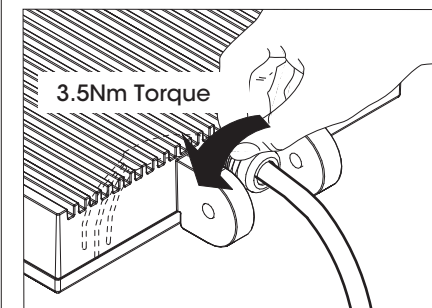
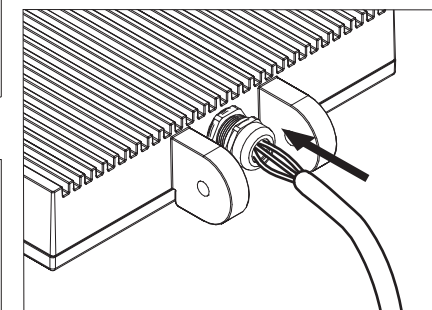
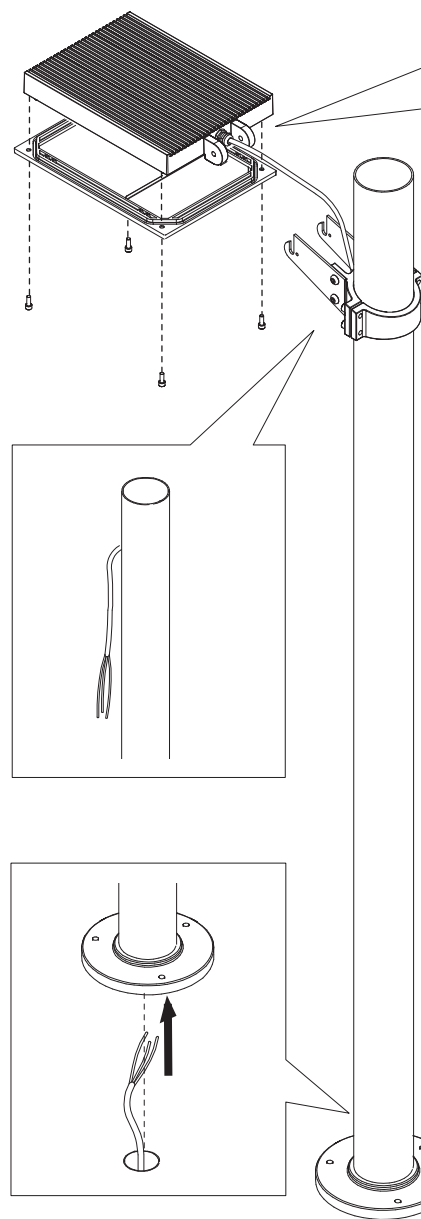

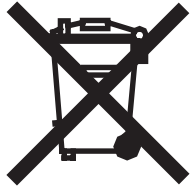

RAEE-WEEE

ITA. Direttiva 2002/96/CE rifiuti di apparecchiature elettriche ed elettroniche /RAEE:
Informazioni agli utenti: ai sensi dell'articolo 13 del Decreto legislativo 25 Luglio del 2005, n. 151 "Attuazione delle Direttive 2002/95/CE, 2002/96/CE e 2003/108/CE, relative alla riduzione dell'uso di sostanze pericolose nelle apparecchiature elettriche ed elettroniche, nonché allo smaltimento dei rifiuti" questo prodotto è conforme.

Il simbolo del cassonetto barrato riportato sull'apparecchiatura o sulle sua confezione indica che il prodotto alla fine della propria vita utile deve essere raccolto separatamente dagli altri rifiuti. L'utente dovrà pertanto conferire l'apparecchiatura giunta a fine vita agli idonei centri di raccolta differenziata dei Rifiuti Elettronici ed Elettrotecnici, oppure riconsegnarla al rivenditore al momento dell'acquisto di una nuova apparecchiatura di tipo equivalente, in ragione di uno a uno. L'adeguata raccolta differenziata per l'avvio successivo dell'apparecchiatura dismessa al riciclaggio, al trattamento ed allo smaltimento ambientalmente compatibile contribuisce ad evitare possibili effetti negativi sull'ambiente e sulla salute e favorisce il rimpiego e/o riciclo dei materiali di cui è composta l'apparecchiatura. Lo smaltimento abusivo del prodotto da parte dell'utente comporta l'applicazione delle sanzioni amministrative previste dalla norma vigente.

UK. Directive 2002/96/EC (Waste Electrical and Electronic Equipment - WEEE):
Information for users.

This product complies with EU Directive 2002/96/EC. The crossed-out wastebasket symbol on the appliance means that at the end of its useful lifespan, the product must be disposed of separately from ordinary household wastes. The user is responsible for delivering the appliance to an appropriate collection facility at the end of its useful lifespan. Appropriate separate collection to permit recycling, treatment and environmentally compatible disposal helps prevent negative impact on the environment and human health and promotes recycling of the materials making up the product. For more information on available collection facilities, contact your local waste collection service or the shop where you bought this appliance.

ESP. Información al consumidor: En relación a la Directiva , 2002/95/CE, 2002/96/CE e 2003/108/CE, relativas a la reducción del uso de sustancias peligrosas en el aparellaje eléctrico y electrónico, así como del reciclaje de los mismos.

Este producto es conforme con la Directiva EU 2002/96/CE. El símbolo de la papelera barrada situado sobre el aparato indica que este producto, al final de su vida útil, debe ser tratado separadamente de los residuos domésticos. El usuario es responsable de la entrega del aparato al final de su vida útil a los centros de recogida autorizados. El adecuado proceso de recogida autorizados. El adecuado proceso de recogida diferenciada permite dirigir el aparato desechado al reciclaje, a su tratamiento y a su desmantelamiento de una forma compatible con el medio ambiente, contribuyendo a evitar los posibles efectos negativos sobre el ambiente y la salud, favoreciendo el reciclaje de los materiales de los que está compuesto el producto. Para información más detallada inherente a los sistemas de recogida o al establecimiento donde se adquirió el producto.

FR. Directive 2002/96/CE (Déchets d'équipements électriques et électroniques - DEEE):
Informations aux utilisateurs.

Ce produit est conforme à la Directive ED 2002/96/CE. Le symbole de la corbeille barrée reporté sur l'appareil indique que ce dernier doit être éliminé à part lorsqu'il n'est plus utilisable et non pas avec les ordures ménagères. L'utilisateur a la responsabilité de porter l'appareil hors d'usage à un centre de ramassage spécialisé. Le tri approprié des déchets permet d'acheminer l'appareil vers le recyclage, le traitement et l'élimination de façon écologiquement compatible. Il contribue à éviter les effets négatifs possibles sur l'environnement et sur la santé, tout en favorisant le recyclage des matériaux dont est constitué le produit. Pour avoir des informations plus détaillées sur les systèmes de ramassage disponibles, s'adresser au service local d'élimination des déchets ou au revendeur.

DE. Richtlinie 2002/96/EU (Elektro- un Elektronik- Aitgeräte - WEEE):
Benutzerinformationen.

Dieses Produkt entspricht der EURichtlinie 2002/96/EU. Das Symbol des auf dem Gerät dargestellten, durchgestrichenen Korbes gibt an, dass das Produkt am Ende seiner Nutzungsdauer gesondert vom Hausmüll zu behandeln ist. Am Ende der Nutzungsdauer ist der Benutzer für die Überantwortung des Geräts an geeignete Sammelstellen verantwortlich. Die angemessene, getrennte Müllsammlung zwecks umweltkompatibler Behandlung und Entsorgung für den anschließenden Recyclingbeginn des nicht mehr verwendeten Geräts trägt zur Vermeidung möglicher schädlicher Wirkungen auf Umwelt und Gesundheit bei und begünstigt das Recycling der Materialien, aus denen das Produkt zusammengesetzt ist. Für nähere Informationen bezüglich der zur Verfügung stehenden Sammelsysteme, wenden Sie sich bitte an den örtlichen Müllentsorgungsdienst oder an das Geschäft, in dem der Kauf getätigt worden ist.

This information only applies to customers in the European Union, according to Directive 2002/96/EC of the European parliament and of the council of 27 January 2003 on waste electrical and electronic equipment (WEE) and legislation transposing and implementing it into the various national legal systems.

ares

THE OUTDOOR BY FLOS

ARES s.r.l. - Socio Unico

Viale dell'Artigianato, 24
20881 Bernareggio - MB - ITALY
Tel. +39 039 6900892
Fax +39 039 6901855
e-mail: flos.outdoor@flos.com
www.aresill.it